



Practice Test 1

PHYSICS C

Physics C has two exams: Physics C (Mechanics) and Physics C (Electricity & Magnetism):

	<u>Physics C (Mechanics)</u>	<u>Physics C (Electricity & Magnetism)</u>
First 45 min.	Sec. I, Multiple Choice 35 questions	Sec. I, Multiple Choice 35 questions
Second 45 min.	Sec. II, Free Response 3 questions	Sec. II, Free Response 3 questions

You may take just Mechanics or just Electricity and Magnetism, or both. If you take both, you will receive a separate grade for each. Each section of each examination is 50 percent of the total grade; each question in a section has equal weight. Calculators are permitted on both sections of the exam. However, calculators cannot be shared with other students and calculators with typewriter-style (QWERTY) keyboards will not be permitted. On the following pages you will find the Table of Information that is provided to you during the exam.

If you are taking

- *Mechanics only*, please be careful to answer numbers 1–35;
- *Electricity and Magnetism only*, please be careful to answer numbers 36–70;
- *the entire examination* (Mechanics and Electricity and Magnetism), answer numbers 1–70 on your answer sheet.

GO ON TO THE NEXT PAGE.

ADVANCED PLACEMENT PHYSICS C TABLE OF INFORMATION

CONSTANTS AND CONVERSION FACTORS			
Proton mass,	$m_p = 1.67 \times 10^{-27} \text{ kg}$	Electron charge magnitude,	$e = 1.60 \times 10^{-19} \text{ C}$
Neutron mass,	$m_n = 1.67 \times 10^{-27} \text{ kg}$	1 electron volt,	$1 \text{ eV} = 1.60 \times 10^{-19} \text{ J}$
Electron mass,	$m_e = 9.11 \times 10^{-31} \text{ kg}$	Speed of light,	$c = 3.00 \times 10^8 \text{ m/s}$
Avogadro's number,	$N_A = 6.02 \times 10^{23} \text{ mol}^{-1}$	Universal gravitational constant,	$G = 6.67 \times 10^{-11} \text{ (N}\cdot\text{m}^2\text{)/kg}^2$
Universal gas constant,	$R = 8.31 \text{ J/(mol K)}$	Acceleration due to gravity at Earth's surface,	$g = 9.8 \text{ m/s}^2$
Boltzmann's constant,	$k_B = 1.38 \times 10^{-23} \text{ J/K}$		
1 unified atomic mass unit,	$1 \text{ u} = 1.66 \times 10^{-27} \text{ kg} = 931 \text{ MeV}/c^2$		
Planck's constant,	$h = 6.63 \times 10^{-34} \text{ J}\cdot\text{s} = 4.14 \times 10^{-15} \text{ eV}\cdot\text{s}$		
	$hc = 1.99 \times 10^{-25} \text{ J}\cdot\text{m} = 1.24 \times 10^3 \text{ eV}\cdot\text{nm}$		
Vacuum permittivity,	$\epsilon_0 = 8.85 \times 10^{-12} \text{ C}^2\text{/(N}\cdot\text{m}^2)$		
Coulomb's law constant,	$k = 1/(4\pi\epsilon_0) = 9.0 \times 10^9 \text{ (N}\cdot\text{m}^2\text{)/C}^2$		
Vacuum permeability,	$\mu_0 = 4\pi \times 10^{-7} \text{ (T}\cdot\text{m)/A}$		
Magnetic constant,	$k' = \mu_0/(4\pi) = 1 \times 10^{-7} \text{ (T}\cdot\text{m)/A}$		
1 atmosphere pressure,	$1 \text{ atm} = 1.0 \times 10^5 \text{ N/m}^2 = 1.0 \times 10^5 \text{ Pa}$		

UNIT SYMBOLS	meter,	m	mole,	mol	watt,	W	farad,	F
	kilogram,	kg	hertz,	Hz	coulomb,	C	tesla,	T
	second,	s	newton,	N	volt,	V	degree Celsius,	°C
	ampere,	A	pascal,	Pa	ohm,	Ω	electron volt,	eV
	kelvin,	K	joule,	J	henry,	H		

VALUES OF TRIGONOMETRIC FUNCTIONS FOR COMMON ANGLES							
θ	0°	30°	37°	45°	53°	60°	90°
$\sin\theta$	0	1/2	3/5	$\sqrt{2}/2$	4/5	$\sqrt{3}/2$	1
$\cos\theta$	1	$\sqrt{3}/2$	4/5	$\sqrt{2}/2$	3/5	1/2	0
$\tan\theta$	0	$\sqrt{3}/3$	3/4	1	4/3	$\sqrt{3}$	∞

PREFIXES		
Factor	Prefix	Symbol
10^9	giga	G
10^6	mega	M
10^3	kilo	k
10^{-2}	centi	c
10^{-3}	milli	m
10^{-6}	micro	μ
10^{-9}	nano	n
10^{-12}	pico	p

The following assumptions are used in this exam.

- I. The frame of reference of any problem is inertial unless otherwise stated.
- II. The direction of current is the direction in which positive charges would drift.
- III. The electric potential is zero at an infinite distance from an isolated point charge.
- IV. All batteries and meters are ideal unless otherwise stated.
- V. Edge effects for the electric field of a parallel plate capacitor are negligible unless otherwise stated.

GO ON TO THE NEXT PAGE.

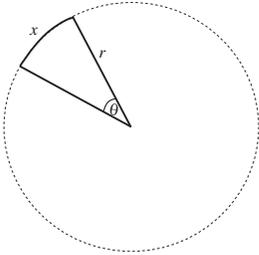
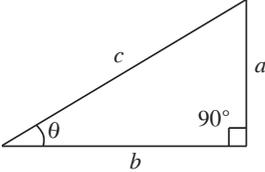
GEOMETRY AND TRIGONOMETRY		CALCULUS
<p>Rectangle</p> <p>$A = bh$</p> <p>Triangle</p> <p>$A = \frac{1}{2}bh$</p> <p>Circle</p> <p>$A = \pi r^2$</p> <p>$C = 2\pi r$</p> <p>$s = r\theta$</p> <p>Rectangular Solid</p> <p>$V = \ell wh$</p> <p>Cylinder</p> <p>$V = \pi r^2 \ell$</p> <p>$S = 2\pi r \ell + 2\pi r^2$</p> <p>Sphere</p> <p>$V = \frac{4}{3}\pi r^3$</p> <p>$S = 4\pi r^2$</p> <p>Right Triangle</p> <p>$a^2 + b^2 = c^2$</p> <p>$\sin \theta = \frac{a}{c}$</p> <p>$\cos \theta = \frac{b}{c}$</p> <p>$\tan \theta = \frac{a}{b}$</p>	<p>$A = \text{area}$</p> <p>$C = \text{circumference}$</p> <p>$V = \text{volume}$</p> <p>$S = \text{surface area}$</p> <p>$b = \text{base}$</p> <p>$h = \text{height}$</p> <p>$\ell = \text{length}$</p> <p>$w = \text{width}$</p> <p>$r = \text{radius}$</p> <p>$s = \text{arc length}$</p> <p>$\theta = \text{angle}$</p>  	<p>$\frac{df}{dx} = \frac{df}{du} \frac{du}{dx}$</p> <p>$\frac{d}{dx}(x^n) = nx^{n-1}$</p> <p>$\frac{d}{dx}(e^{ax}) = ae^{ax}$</p> <p>$\frac{d}{dx}(\ln ax) = \frac{1}{x}$</p> <p>$\frac{d}{dx}[\sin(ax)] = a \cos(ax)$</p> <p>$\frac{d}{dx}[\cos(ax)] = -a \sin(ax)$</p> <p>$\int x^n dx = \frac{1}{n+1} x^{n+1}, n \neq -1$</p> <p>$\int e^{ax} dx = \frac{1}{a} e^{ax}$</p> <p>$\int \frac{dx}{x+a} = \ln x+a$</p> <p>$\int \cos(ax) dx = \frac{1}{a} \sin(ax)$</p> <p>$\int \sin(ax) dx = -\frac{1}{a} \cos(ax)$</p> <p>VECTOR PRODUCTS</p> <p>$\vec{A} \cdot \vec{B} = AB \cos \theta$</p> <p>$\vec{A} \times \vec{B} = AB \sin \theta$</p>

GO ON TO THE NEXT PAGE.

PHYSICS C
SECTION I, MECHANICS

Time—45 minutes

35 Questions

Directions: Each of the questions or incomplete statements below is followed by five suggested answers or completions. Select the one that is best in each case and then mark it on your answer sheet.

1. A rock is dropped off a cliff and falls the first half of the distance to the ground in t_1 seconds. If it falls the second half of the distance in t_2 seconds, what is the value of t_2/t_1 ? (Ignore air resistance.)

- (A) $1/(2\sqrt{2})$
 (B) $1/\sqrt{2}$
 (C) $1/2$
 (D) $1 - (1/\sqrt{2})$
 (E) $\sqrt{2} - 1$

2. A bubble starting at the bottom of a soda bottle experiences constant acceleration, a , as it rises to the top of the bottle in some time, t . How much farther does it travel in the last second of its journey than in the first second? Assume that the journey takes longer than 2 seconds.

- (A) $a(t + 1 \text{ s})^2$
 (B) $a(t - 1 \text{ s})^2$
 (C) at^2
 (D) $a(t + 1 \text{ s})(1 \text{ s})$
 (E) $a(t - 1 \text{ s})(1 \text{ s})$

3. An object initially at rest experiences a time-varying acceleration given by $a = (2 \text{ m/s}^3)t$ for $t \geq 0$. How far does the object travel in the first 3 seconds?

- (A) 9 m
 (B) 12 m
 (C) 18 m
 (D) 24 m
 (E) 27 m

4. What is the fewest number of the following conditions to ensure that angular momentum is conserved?

- I. Conservation of linear momentum
 II. Zero net external force
 III. Zero net external torque

- (A) II only
 (B) III only
 (C) I and II only
 (D) I and III only
 (E) II and III only

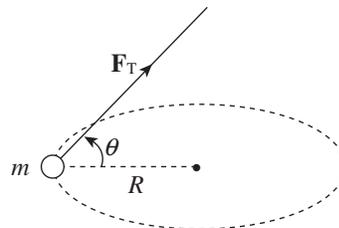

5. In the figure shown, a tension force F_T causes a particle of mass m to move with constant angular speed ω in a horizontal circular path (in a plane perpendicular to the page) of radius R . Which of the following expressions gives the magnitude of F_T ? Ignore air resistance.

- (A) $m\omega^2 R$
 (B) $m\sqrt{\omega^4 R^2 - g^2}$
 (C) $m\sqrt{\omega^4 R^2 + g^2}$
 (D) $m(\omega^2 R - g)$
 (E) $m(\omega^2 R + g)$

6. An object (mass = m) above the surface of the Moon (mass = M) is dropped from an altitude h equal to the Moon's radius (R). With what speed will the object strike the lunar surface?

- (A) $\sqrt{GM/R}$
 (B) $\sqrt{GM/(2R)}$
 (C) $\sqrt{2GM/R}$
 (D) $\sqrt{2GMm/R}$
 (E) $\sqrt{GMm/(2R)}$

GO ON TO THE NEXT PAGE.

7. Pretend that someone managed to dig a hole straight through the center of the Earth all the way to the other side. If an object were dropped down that hole, which of the following would best describe its motion? Assume ideal conditions (Earth is a perfect sphere, there are no dissipative forces) and that the object cannot be destroyed.

- (A) It would fall to the center of the Earth and stop there.
 (B) It would fall through the hole to the other side, continue past the opposite side's opening, and fly into space.
 (C) It would oscillate back and forth from one opening to the other indefinitely.
 (D) It would oscillate back and forth, but the amplitude would decrease each time, eventually settling at the center of the Earth.
 (E) It would fall to the other side and stop there.

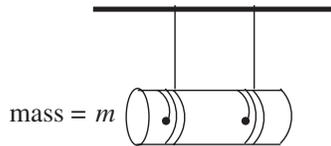

8. A uniform cylinder of mass m and radius r unrolls without slipping from two strings tied to a vertical support. If the rotational inertia of the cylinder is $\frac{1}{2}mr^2$, find the acceleration of its center of mass.

- (A) $\frac{1}{4}g$
 (B) $\frac{1}{2}g$
 (C) $\frac{1}{3}g$
 (D) $\frac{2}{3}g$
 (E) $\frac{3}{4}g$

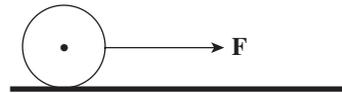

9. A uniform cylinder, initially at rest on a frictionless, horizontal surface, is pulled by a constant force F from time $t = 0$ to time $t = T$. From time $t = T$ on, this force is removed. Which of the following graphs best illustrates the speed, v , of the cylinder's center of mass from $t = 0$ to $t = 2T$?

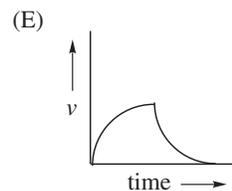
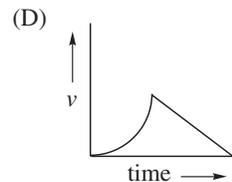
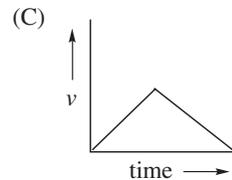
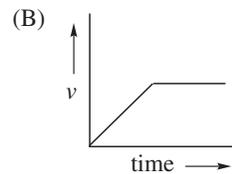
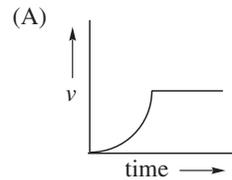

GO ON TO THE NEXT PAGE.

10. A space shuttle is launched from Earth. As it travels up, it moves at a constant velocity of 150 m/s straight up. If its engines provide 1.5×10^8 W of power, what is the shuttle's mass? You may assume that the shuttle's mass and the acceleration due to gravity are constant.
- (A) 6.7×10^2 kg
 (B) 1.0×10^5 kg
 (C) 6.7×10^5 kg
 (D) 1.0×10^6 kg
 (E) 2.3×10^6 kg
11. A satellite is in circular orbit around Earth. If the work required to lift the satellite to its orbital height is equal to the satellite's kinetic energy while in this orbit, how high above the surface of Earth (radius = R) is the satellite?
- (A) $\frac{1}{2}R$
 (B) $\frac{2}{3}R$
 (C) R
 (D) $\frac{3}{2}R$
 (E) $2R$

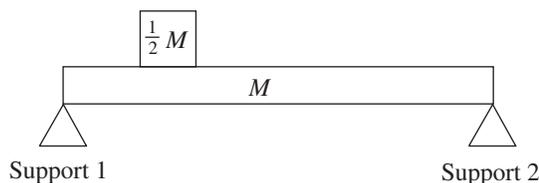

12. The figure above shows a uniform bar of mass M resting on two supports. A block of mass $\frac{1}{2}M$ is placed on the bar twice as far from Support 2 as from Support 1. If \mathbf{F}_1 and \mathbf{F}_2 denote the downward forces on Support 1 and Support 2, respectively, what is the value of $\mathbf{F}_2/\mathbf{F}_1$?
- (A) $\frac{1}{2}$
 (B) $\frac{2}{3}$
 (C) $\frac{3}{4}$
 (D) $\frac{4}{5}$
 (E) $\frac{5}{6}$
13. A rubber ball (mass = 0.08 kg) is dropped from a height of 3.2 m and, after bouncing off the floor, rises almost to its original height. If the impact time with the floor is measured to be 0.04 s, what average force did the floor exert on the ball?
- (A) 0.16 N
 (B) 16 N
 (C) 32 N
 (D) 36 N
 (E) 64 N
14. A disk of radius 0.1 m initially at rest undergoes an angular acceleration of 2.0 rad/s^2 . If the disk only rotates, find the total distance traveled by a point on the rim of the disk in 4.0 s.
- (A) 0.4 m
 (B) 0.8 m
 (C) 1.2 m
 (D) 1.6 m
 (E) 2.0 m

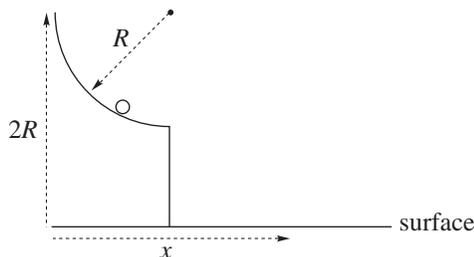

15. In the figure above, a small object slides down a frictionless quarter-circular slide of radius R . If the object starts from rest at a height equal to $2R$ above a horizontal surface, find its horizontal displacement, x , at the moment it strikes the surface.
- (A) $2R$
 (B) $\frac{5}{2}R$
 (C) $3R$
 (D) $\frac{7}{2}R$
 (E) $4R$

GO ON TO THE NEXT PAGE.

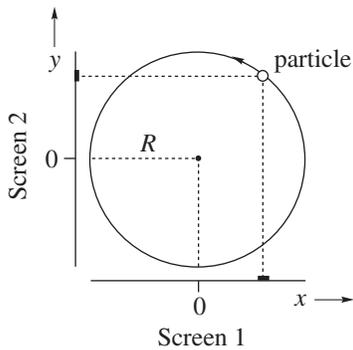

16. The figure above shows a particle executing uniform circular motion in a circle of radius R . Light sources (not shown) cause shadows of the particle to be projected onto two mutually perpendicular screens. The positive directions for x and y along the screens are denoted by the arrows. When the shadow on Screen 1 is at position $x = -(0.5)R$ and moving in the $+x$ direction, what is true about the position and velocity of the shadow on Screen 2 at that same instant?
- (A) $y = -(0.866)R$; velocity in $-y$ direction
 (B) $y = -(0.866)R$; velocity in $+y$ direction
 (C) $y = -(0.5)R$; velocity in $-y$ direction
 (D) $y = +(0.866)R$; velocity in $-y$ direction
 (E) $y = +(0.866)R$; velocity in $+y$ direction

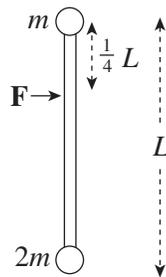

17. The figure shows a view from above of two objects attached to the end of a rigid massless rod at rest on a frictionless table. When a force \mathbf{F} is applied as shown, the resulting rotational acceleration of the rod about its center of mass is $kF/(mL)$. What is k ?
- (A) $\frac{3}{8}$
 (B) $\frac{1}{2}$
 (C) $\frac{5}{8}$
 (D) $\frac{3}{4}$
 (E) $\frac{5}{6}$

18. A toy car and a toy truck collide. If the toy truck's mass is double the toy car's mass, then, compared to the acceleration of the truck, the acceleration of the car during the collision will be
- (A) double the magnitude and in the same direction
 (B) double the magnitude and in the opposite direction
 (C) half the magnitude and in the same direction
 (D) half the magnitude and in the opposite direction
 (E) dependent on the type of collision
19. A homogeneous bar is lying on a flat table. Besides the gravitational and normal forces (which cancel), the bar is acted upon by exactly two other external forces, \mathbf{F}_1 and \mathbf{F}_2 , which are parallel to the surface of the table. If the net force on the rod is zero, which one of the following is also true?
- (A) The net torque on the bar must also be zero.
 (B) The bar cannot accelerate translationally or rotationally.
 (C) The bar can accelerate translationally if \mathbf{F}_1 and \mathbf{F}_2 are not applied at the same point.
 (D) The net torque will be zero if \mathbf{F}_1 and \mathbf{F}_2 are applied at the same point.
 (E) None of the above
20. An astronaut lands on a planet whose mass and radius are each twice that of Earth. If the astronaut weighs 800 N on Earth, how much will he weigh on this planet?
- (A) 200 N
 (B) 400 N
 (C) 800 N
 (D) 1,600 N
 (E) 3,200 N

GO ON TO THE NEXT PAGE.

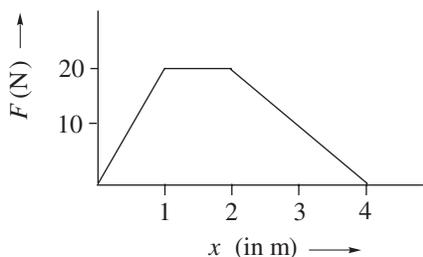

21. A particle of mass $m = 1.0$ kg is acted upon by a variable force, $F(x)$, whose strength is given by the graph given above. If the particle's speed was zero at $x = 0$, what is its speed at $x = 4$ m?
- (A) 5.0 m/s
 (B) 8.7 m/s
 (C) 10 m/s
 (D) 14 m/s
 (E) 20 m/s
22. The radius of a collapsing spinning star (assumed to be a uniform sphere with a constant mass) decreases to $\frac{1}{16}$ of its initial value. What is the ratio of the final rotational kinetic energy to the initial rotational kinetic energy?
- (A) 4
 (B) 16
 (C) 16^2
 (D) 16^3
 (E) 16^4

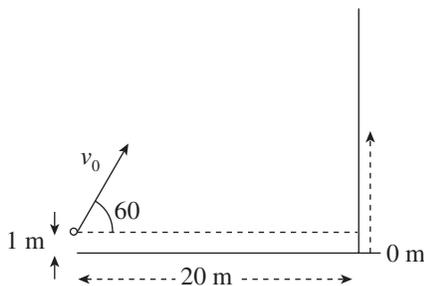

23. A ball is projected with an initial velocity of magnitude $v_0 = 40$ m/s toward a vertical wall as shown in the figure above. How long does the ball take to reach the wall?
- (A) 0.25 s
 (B) 0.6 s
 (C) 1.0 s
 (D) 2.0 s
 (E) 3.0 s

24. If C, M, L, and T represent the dimensions of charge, mass, length, and time respectively, what are the dimensions of the permittivity of free space (ϵ_0)?
- (A) $T^2C^2/(M^2L^2)$
 (B) $T^2C^2/(ML^3)$
 (C) $ML^3/(T^2C^2)$
 (D) $C^2M/(T^2L^2)$
 (E) $T^2L^2/(C^2M)$

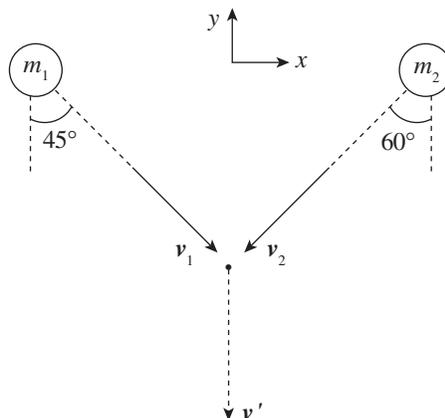

25. The figure shown is a view from above of two clay balls moving toward each other on a frictionless surface. They collide perfectly inelastically at the indicated point and are observed to then move in the direction indicated by the post-collision velocity vector, v' . If $m_1 = 2m_2$, and v' is parallel to the negative y-axis, what is v_2 ?
- (A) $v_1(\sin 45^\circ)/(2 \sin 60^\circ)$
 (B) $v_1(\cos 45^\circ)/(2 \cos 60^\circ)$
 (C) $v_1(2 \cos 45^\circ)/(\cos 60^\circ)$
 (D) $v_1(2 \sin 45^\circ)/(\sin 60^\circ)$
 (E) $v_1(\cos 45^\circ)/(2 \sin 60^\circ)$

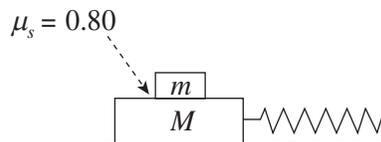

26. In the figure above, the coefficient of static friction between the two blocks is 0.80. If the blocks oscillate with a frequency of 2.0 Hz, what is the maximum amplitude of the oscillations if the small block is not to slip on the large block?
- (A) 3.1 cm
 (B) 5.0 cm
 (C) 6.2 cm
 (D) 7.5 cm
 (E) 9.4 cm

GO ON TO THE NEXT PAGE.

27. When two objects collide, the ratio of the relative speed after the collision to the relative speed before the collision is called the *coefficient of restitution*, e . If a ball is dropped from height H_1 onto a stationary floor, and the ball rebounds to height H_2 , what is the coefficient of restitution of the collision?

- (A) H_1/H_2
 (B) H_2/H_1
 (C) $\sqrt{H_1/H_2}$
 (D) $\sqrt{H_2/H_1}$
 (E) $(H_1/H_2)^2$

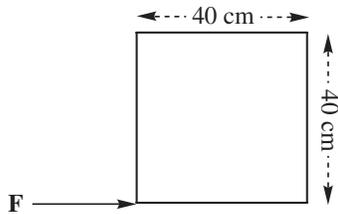

28. The figure above shows a square metal plate of side length 40 cm and uniform density, lying flat on a table. A force \mathbf{F} of magnitude 10 N is applied at one of the corners, as shown. Determine the torque produced by \mathbf{F} relative to the center of rotation.

- (A) 0 N·m
 (B) 1.0 N·m
 (C) 1.4 N·m
 (D) 2.0 N·m
 (E) 4.0 N·m

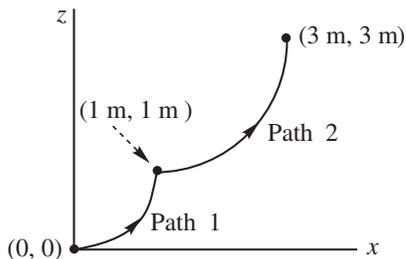

29. A small block of mass $m = 2.0$ kg is pushed from the initial point $(x_i, z_i) = (0 \text{ m}, 0 \text{ m})$ upward to the final point $(x_f, z_f) = (3 \text{ m}, 3 \text{ m})$ along the path indicated. Path 1 is a portion of the parabola $z = x^2$, and Path 2 is a quarter circle whose equation is $(x - 1)^2 + (z - 3)^2 = 4$. How much work is done by gravity during this displacement?

- (A) -60 J
 (B) -80 J
 (C) -90 J
 (D) -100 J
 (E) -120 J

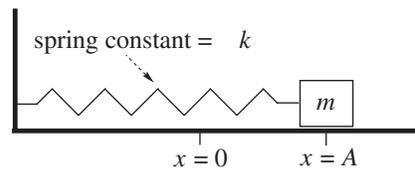

30. In the figure shown, the block (mass = m) is at rest at $x = A$. As it moves back toward the wall due to the force exerted by the stretched spring, it is also acted upon by a frictional force whose strength is given by the expression bx , where b is a positive constant. What is the block's speed when it first passes through the equilibrium position ($x = 0$)?

- (A) $A\sqrt{(k+b)/m}$
 (B) $A\sqrt{(k-b)/m}$
 (C) $A\sqrt{(\frac{1}{2}k+b)/m}$
 (D) $A\sqrt{(\frac{1}{2}k-b)/m}$
 (E) $A\sqrt{\frac{1}{2}(k-b)/m}$

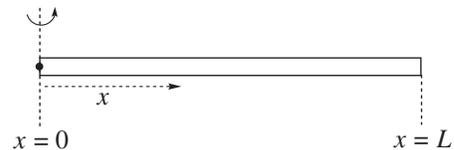

31. The rod shown above can pivot about the point $x = 0$ and rotates in a plane perpendicular to the page. Its linear density, λ , increases with x such that $\lambda(x) = kx$, where k is a positive constant. Determine the rod's moment of inertia in terms of its length, L , and its total mass, M .

- (A) $\frac{1}{6}ML^2$
 (B) $\frac{1}{4}ML^2$
 (C) $\frac{1}{3}ML^2$
 (D) $\frac{1}{2}ML^2$
 (E) $2ML^2$

GO ON TO THE NEXT PAGE.

32. A particle is subjected to a conservative force whose potential energy function is

$$U(x) = (x - 2)^3 - 12x$$

where U is given in joules when x is measured in meters. Which of the following represents a position of stable equilibrium?

- (A) $x = -4$
 (B) $x = -2$
 (C) $x = 0$
 (D) $x = 2$
 (E) $x = 4$

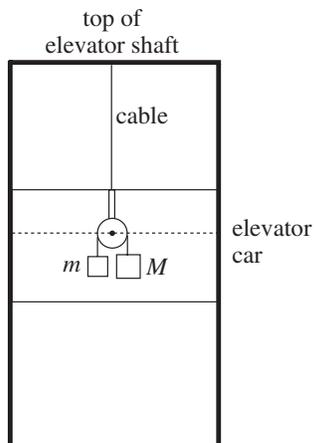

33. A light, frictionless pulley is suspended from a rigid rod attached to the roof of an elevator car. Two masses, m and M (with $M > m$), are suspended on either side of the pulley by a light, inextendable cord. The elevator car is descending at a constant velocity. Determine the acceleration of the masses.

- (A) $(M - m)g$
 (B) $(M + m)g$
 (C) $\frac{M + m}{M - m}g$
 (D) $\frac{M - m}{M + m}g$
 (E) $(M - m)(M + m)g$

34. A particle's kinetic energy is changing at a rate of -6.0 J/s when its speed is 3.0 m/s. What is the magnitude of the force on the particle at this moment?

- (A) 0.5 N
 (B) 2.0 N
 (C) 4.5 N
 (D) 9.0 N
 (E) 18 N

35. An object of mass 2 kg is acted upon by three external forces, each of magnitude 4 N. Which of the following could NOT be the resulting acceleration of the object?

- (A) 0 m/s²
 (B) 2 m/s²
 (C) 4 m/s²
 (D) 6 m/s²
 (E) 8 m/s²

STOP

END OF SECTION I, MECHANICS

PHYSICS C
SECTION II, MECHANICS

Time—45 minutes

3 Questions

Directions: Answer all three questions. The suggested time is about 15 minutes per question for answering each of the questions, which are worth 15 points each. The parts within a question may not have equal weight.

Mech 1. An ideal projectile is launched from the ground at an angle θ to the horizontal, with an initial speed of v_0 . The ground is flat and level everywhere. Write all answers in terms of v_0 , θ , and fundamental constants.

- (a) Calculate the time the object is in the air.
- (b) Calculate the maximum height the object reaches.
- (c) What is the *net* vertical displacement of the object?
- (d) Calculate the range (horizontal displacement) of the object.
- (e) What should θ be so that the projectile's range is equal to its maximum vertical displacement?

GO ON TO THE NEXT PAGE.

- Mech 2. A narrow tunnel is drilled through Earth (mass = M , radius = R), connecting points P and Q, as shown in the diagram on the left below. The perpendicular distance from Earth's center, C, to the tunnel is x . A package (mass = m) is dropped from Point P into the tunnel; its distance from P is denoted y and its distance from C is denoted r . See the diagram on the right.

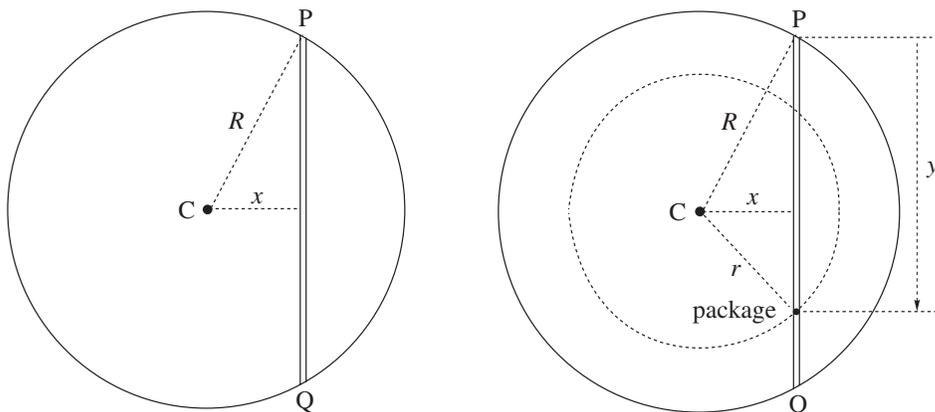

- (a) Assuming that Earth is a homogeneous sphere, the gravitational force F on the package is due to m and the mass contained within the sphere of radius $r < R$. Use this fact to show that

$$F = -\frac{GMm}{R^3}r$$

- (b) Use the equation $F(r) = -dU/dr$ to find an expression for the change in gravitational potential energy of the package as it moves from Point P to a point where its distance from Earth's center is r . Write your answer in terms of G , M , m , R , and r .
- (c) Apply Conservation of Energy to determine the speed of the package in terms of G , M , R , x , and y . (Ignore friction.)
- (d) (i) At what point in the tunnel—that is, for what value of y —will the speed of the package be maximized?
(ii) What is this maximum speed? (Write your answer in terms of G , M , R , and x .)

GO ON TO THE NEXT PAGE.

- Mech 3. The diagram below is a view from above of three sticky hockey pucks on a frictionless horizontal surface. The pucks with masses m and $2m$ are connected by a massless rigid rod of length L and are initially at rest. The puck of mass $3m$ is moving with velocity v directly toward puck m . When puck $3m$ strikes puck m , the collision is perfectly inelastic.

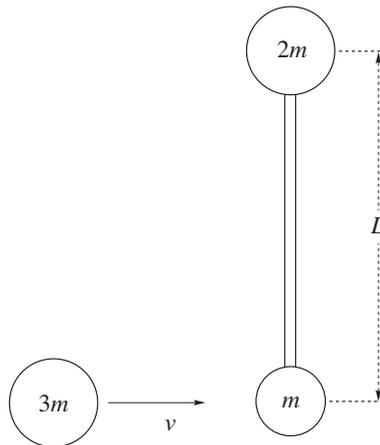

- (a) Immediately after the collision,
- (i) where is the center of mass of the system?
 - (ii) what is the speed of the center of mass? (Write your answer in terms of v .)
 - (iii) what is the angular speed of the system? (Write your answer in terms of v and L .)
- (b) What fraction of the system's initial kinetic energy is lost as a result of the collision?

STOP

END OF SECTION II, MECHANICS

PHYSICS C
SECTION I, ELECTRICITY AND MAGNETISM

Time—45 minutes

35 Questions

Directions: Each of the questions or incomplete statements below is followed by five suggested answers or completions. Select the one that is best in each case and mark it on your answer sheet.

36. A nonconducting sphere is given a nonzero net electric charge, $+Q$, and then brought close to a neutral conducting sphere of the same radius. Which of the following will be true?
- (A) An electric field will be induced within the conducting sphere.
 - (B) The conducting sphere will develop a net electric charge of $-Q$.
 - (C) The spheres will experience an electrostatic attraction.
 - (D) The spheres will experience an electrostatic repulsion.
 - (E) The spheres will experience no electrostatic interaction.
37. Which set of capacitors, C_1 and C_2 , would reach maximum charge most rapidly?
- (A) $C_1 = 2 \mu\text{F}$ and $C_2 = 5 \mu\text{F}$, arranged in parallel
 - (B) $C_1 = 2 \mu\text{F}$ and $C_2 = 5 \mu\text{F}$, arranged in series
 - (C) $C_1 = 3 \mu\text{F}$ and $C_2 = 4 \mu\text{F}$, arranged in parallel
 - (D) $C_1 = 3 \mu\text{F}$ and $C_2 = 4 \mu\text{F}$, arranged in series
 - (E) More than one of the above would be most rapid.
38. Each of the following ionized isotopes is projected with the same speed into a uniform magnetic field \mathbf{B} such that the isotope's initial velocity is perpendicular to \mathbf{B} . Which combination of mass and charge would result in a circular path with the largest radius?
- (A) $m = 16 u, q = -5 e$
 - (B) $m = 17 u, q = -4 e$
 - (C) $m = 18 u, q = -3 e$
 - (D) $m = 19 u, q = -2 e$
 - (E) $m = 20 u, q = -1 e$

GO ON TO THE NEXT PAGE.

39. An ellipsoid-shaped conductor is negatively charged. Which one of the following diagrams best illustrates the charge distribution and electric field lines?

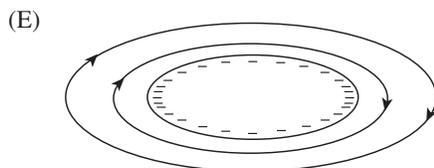
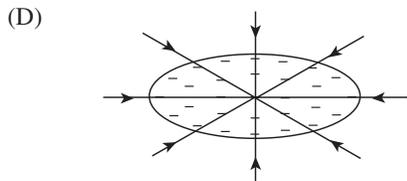
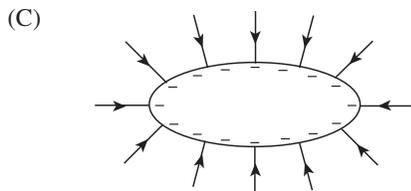
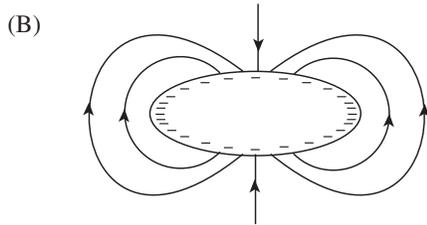
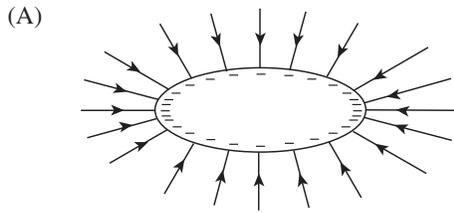

A _____

B _____

C _____

D _____

40. The four wires shown above are each made of aluminum. Which wire will have the greatest resistance?

- (A) Wire A
 (B) Wire B
 (C) Wire C
 (D) Wire D
 (E) All the wires have the same resistance because they're all composed of the same material.

41. Which of the following is NOT equal to one tesla?

- (A) $1 \text{ J}/(\text{A}\cdot\text{m}^2)$
 (B) $1 \text{ kg}/(\text{C}\cdot\text{s})$
 (C) $1 \text{ N}/(\text{A}\cdot\text{m})$
 (D) $1 \text{ V}\cdot\text{s}/\text{m}^2$
 (E) $1 \text{ A}\cdot\text{N}/\text{V}$

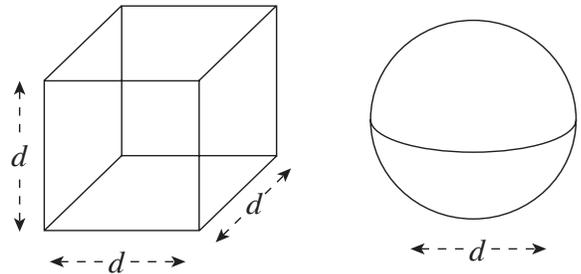

42. The figure above shows two Gaussian surfaces: a cube with side length d and a sphere with diameter d . The net electric charge enclosed within each surface is the same, $+Q$. If Φ_C denotes the total electric flux through the cubical surface, and Φ_S denotes the total electric flux through the spherical surface, then which of the following is true?

- (A) $\Phi_C = (\pi/6)\Phi_S$
 (B) $\Phi_C = (\pi/3)\Phi_S$
 (C) $\Phi_C = \Phi_S$
 (D) $\Phi_C = (3/\pi)\Phi_S$
 (E) $\Phi_C = (6/\pi)\Phi_S$

GO ON TO THE NEXT PAGE.

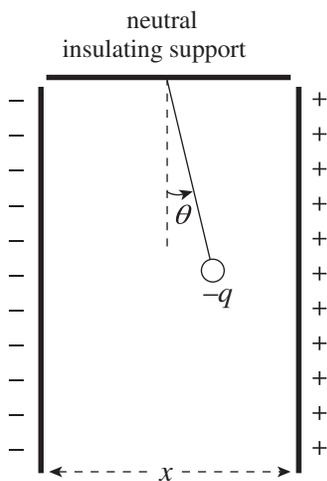

43. The figure above shows two large vertical conducting plates that carry equal but opposite charges. A ball of mass m and charge $-q$ is suspended from a light string in the region between the plates. If the voltage between the plates is V , which of the following gives the angle θ ?
- (A) $\cos^{-1}(qV/mgx)$
 (B) $\sin^{-1}(qV/mgx)$
 (C) $\tan^{-1}(qV/mgx)$
 (D) $\cos^{-1}(qV/x)$
 (E) $\sin^{-1}(qV/x)$
44. An object carries a charge of -1 C. How many excess electrons does it contain?
- (A) 6.25×10^{18}
 (B) 8.00×10^{18}
 (C) 1.60×10^{19}
 (D) 3.20×10^{19}
 (E) 6.25×10^{19}

Questions 45-46

Each of the resistors shown in the circuit below has a resistance of 200Ω . The emf of the ideal battery is 24 V.

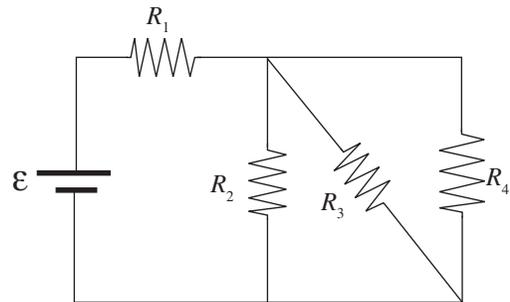

45. How much current is provided by the source?
- (A) 30 mA
 (B) 48 mA
 (C) 64 mA
 (D) 72 mA
 (E) 90 mA
46. What is the ratio of the power dissipated by R_1 to the power dissipated by R_4 ?
- (A) 1/9
 (B) 1/4
 (C) 1
 (D) 4
 (E) 9

GO ON TO THE NEXT PAGE.

47. What is the value of the following product?

$$20 \mu\text{F} \times 500 \Omega$$

- (A) 0.01 henry
 (B) 0.01 ampere per coulomb
 (C) 0.01 weber
 (D) 0.01 second
 (E) 0.01 volt per ampere

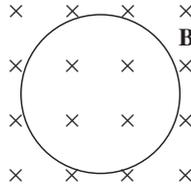

48. A copper wire in the shape of a circle of radius 1 m, lying in the plane of the page, is immersed in a magnetic field, \mathbf{B} , that points into the plane of the page. The strength of \mathbf{B} varies with time, t , according to the equation

$$B(t) = 2t(1 - t)$$

where B is given in teslas when t is measured in seconds. What is the magnitude of the induced electric field in the wire at time $t = 1$ s?

- (A) $(1/\pi)$ N/C
 (B) 1 N/C
 (C) 2 N/C
 (D) π N/C
 (E) 2π N/C

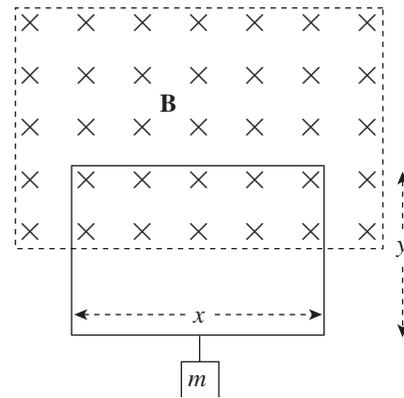

49. In the figure above, the top half of a rectangular loop of wire, x meters by y meters, hangs vertically in a uniform magnetic field, \mathbf{B} . Describe the magnitude and direction of the current in the loop necessary for the magnetic force to balance the weight of the mass m supported by the loop.

- (A) $I = mg/xB$, clockwise
 (B) $I = mg/xB$, counterclockwise
 (C) $I = mg / \left(x + \frac{1}{2}y \right) B$, clockwise
 (D) $I = mg / \left(x + \frac{1}{2}y \right) B$, counterclockwise
 (E) $I = mg/(x+y)B$, clockwise

GO ON TO THE NEXT PAGE.

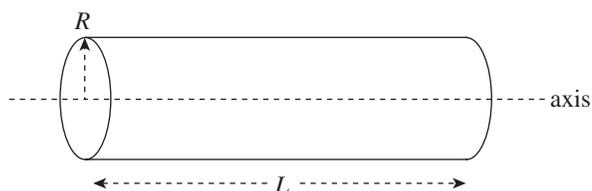

50. A solid nonconducting cylinder of radius R and length L contains a volume charge density given by the equation $\rho(r) = (+2 \text{ C/m}^4)r$, where r is the radial distance from the cylinder's central axis. This means that the total charge contained within a concentric cylinder of radius $r < R$ and length $\ell < L$ is equal to $\pi r^2 \ell \rho$. Find an expression for the strength of the electric field inside this cylinder.

- (A) $1/\epsilon_0 r^2$
 (B) $r/2\epsilon_0$
 (C) $2r/\epsilon_0$
 (D) r^2/ϵ_0
 (E) $r^2/2\epsilon_0$

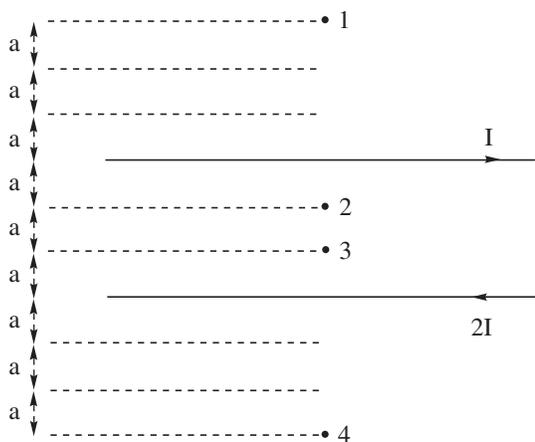

51. The figure above shows a pair of long, straight current-carrying wires and four marked points. At which of these points is the net magnetic field zero?
- (A) Point 1 only
 (B) Points 1 and 2 only
 (C) Point 2 only
 (D) Points 3 and 4 only
 (E) Point 3 only

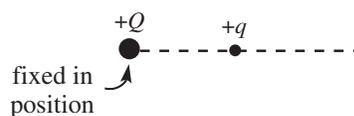

52. The figure above shows two positively charged particles. The $+Q$ charge is fixed in position, and the $+q$ charge is brought close to $+Q$ and released from rest. Which of the following graphs best depicts the acceleration of the $+q$ charge as a function of its distance r from $+Q$?

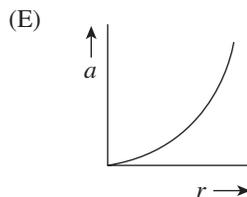
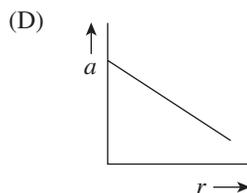
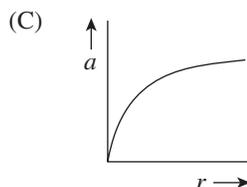
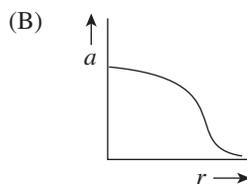
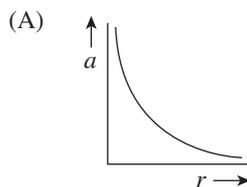

GO ON TO THE NEXT PAGE.

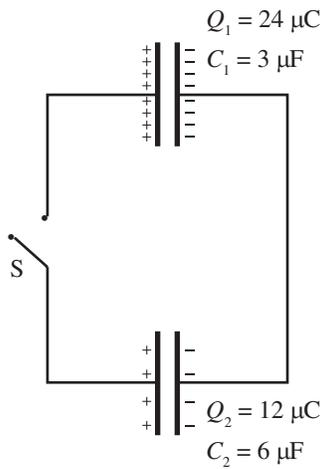

53. Once the switch S in the figure above is closed and electrostatic equilibrium is regained, how much charge will be stored on the positive plate of the $6 \mu\text{F}$ capacitor?
- (A) $9 \mu\text{C}$
 (B) $18 \mu\text{C}$
 (C) $24 \mu\text{C}$
 (D) $27 \mu\text{C}$
 (E) $36 \mu\text{C}$

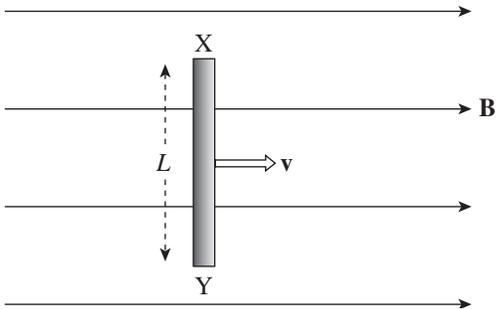

54. A metal bar of length L is pulled with velocity v through a uniform magnetic field, \mathbf{B} , as shown above. What is the voltage produced between the ends of the bar?
- (A) vB , with Point X at a higher potential than Point Y
 (B) vB , with Point Y at a higher potential than Point X
 (C) vBL , with Point X at a higher potential than Point Y
 (D) vBL , with Point Y at a higher potential than Point X
 (E) None of the above

55. An electric dipole consists of a pair of equal but opposite point charges of magnitude 4.0 nC separated by a distance of 2.0 cm . What is the electric field strength at the point midway between the charges?
- (A) 0
 (B) $9.0 \times 10^4 \text{ V/m}$
 (C) $1.8 \times 10^5 \text{ V/m}$
 (D) $3.6 \times 10^5 \text{ V/m}$
 (E) $7.2 \times 10^5 \text{ V/m}$

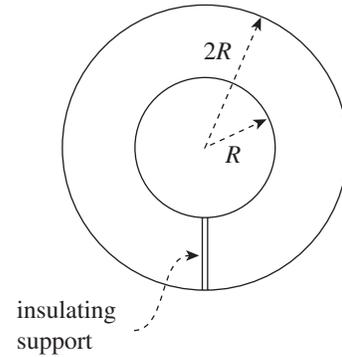

56. The figure above shows a cross section of two concentric spherical metal shells of radii R and $2R$, respectively. Find the capacitance.
- (A) $1/(8\pi\epsilon_0 R)$
 (B) $1/(4\pi\epsilon_0 R)$
 (C) $2\pi\epsilon_0 R$
 (D) $4\pi\epsilon_0 R$
 (E) $8\pi\epsilon_0 R$
57. Traveling at an initial speed of $1.5 \times 10^6 \text{ m/s}$, a proton enters a region of constant magnetic field, \mathbf{B} , of magnitude 1.0 T . If the proton's initial velocity vector makes an angle of 30° with the direction of \mathbf{B} , compute the proton's speed 4 s after entering the magnetic field.
- (A) $5.0 \times 10^5 \text{ m/s}$
 (B) $7.5 \times 10^5 \text{ m/s}$
 (C) $1.5 \times 10^6 \text{ m/s}$
 (D) $3.0 \times 10^6 \text{ m/s}$
 (E) $6.0 \times 10^6 \text{ m/s}$

GO ON TO THE NEXT PAGE.

Questions 58-60

There is initially no current through any circuit element in the following diagram.

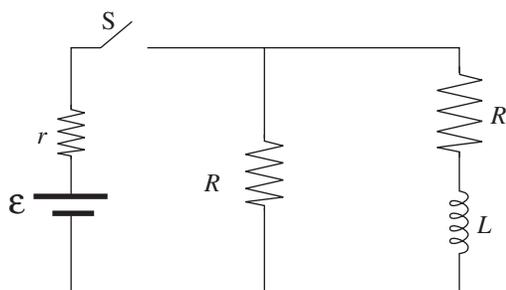

58. What is the current through r immediately after the switch S is closed?

- (A) 0
 (B) $\frac{\mathcal{E}}{r+R}$
 (C) $\frac{\mathcal{E}}{r+2R}$
 (D) $\frac{\mathcal{E}(r+R)}{rR}$
 (E) $\frac{\mathcal{E}(2R)}{2Rr+2R}$

59. After the switch has been kept closed for a long time, how much energy is stored in the inductor?

- (A) $\frac{L\mathcal{E}^2}{2(r+R)^2}$
 (B) $\frac{L\mathcal{E}^2}{2(2r+R)^2}$
 (C) $\frac{L\mathcal{E}^2}{4(2r+R)^2}$
 (D) $\frac{L(\mathcal{E}R)^2}{8(2r+R)^2}$
 (E) $\frac{L\mathcal{E}^2}{8(2r+R)^2}$

60. After having been closed for a long time, the switch is suddenly opened. What is the current through r immediately after S is opened?

- (A) 0
 (B) $\frac{\mathcal{E}}{r+R}$
 (C) $\frac{\mathcal{E}}{r+2R}$
 (D) $\frac{\mathcal{E}(r+R)}{rR}$
 (E) $\frac{\mathcal{E}(2R)}{r(2R)+2R}$

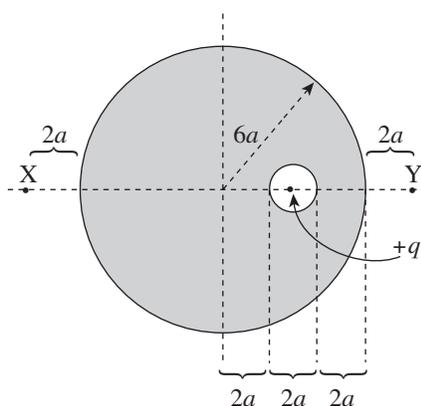

61. A solid, neutral metal sphere of radius $6a$ contains a small cavity, a spherical hole of radius a as shown above. Within this cavity is a charge, $+q$. If E_X and E_Y denote the strength of the electric field at points X and Y , respectively, which of the following is true?

- (A) $E_Y = 4E_X$
 (B) $E_Y = 16E_X$
 (C) $E_Y = E_X$
 (D) $E_Y = (11/5)E_X$
 (E) $E_Y = (11/5)^2E_X$

GO ON TO THE NEXT PAGE.

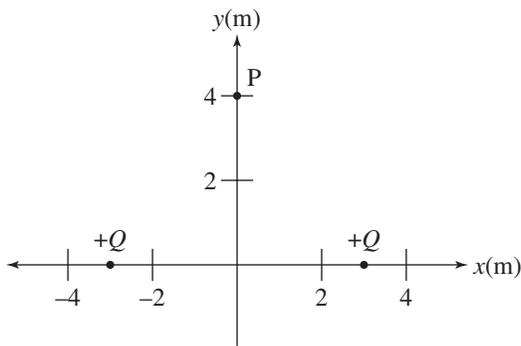

62. Two particles of charge $+Q$ are located on the x -axis, as shown above. Determine the work done by the electric field to move a particle of charge $-Q$ from very far away to point P.

- (A) $\frac{2kQ}{5}$
 (B) $\frac{2kQ^2}{5}$
 (C) $-\frac{2kQ^2}{5}$
 (D) $\frac{kQ^2}{5}$
 (E) $-\frac{3kQ^2}{5}$

63. A battery is connected in a series with a switch, a resistor of resistance R , and an inductor of inductance L . Initially, there is no current in the circuit. Once the switch is closed and the circuit is completed, how long will it take for the current to reach 99% of its maximum value?

- (A) $(\ln \frac{99}{100})RL$
 (B) $(\ln 99)RL$
 (C) $(\ln \frac{1}{100})\frac{L}{R}$
 (D) $\frac{L}{R}(\ln \frac{100}{99})$
 (E) $(\ln 100)\frac{L}{R}$

64. What is the maximum number of 40 W light bulbs that could be connected in parallel with a 120 V source? The total current cannot exceed 5 A or the circuit will blow a fuse.

- (A) 3
 (B) 6
 (C) 9
 (D) 12
 (E) 15

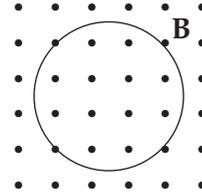

65. The metal loop of wire shown above is situated in a magnetic field \mathbf{B} pointing out of the plane of the page. If \mathbf{B} decreases uniformly in strength, the induced electric current within the loop is

- (A) clockwise and decreasing
 (B) clockwise and increasing
 (C) counterclockwise and decreasing
 (D) counterclockwise and constant
 (E) counterclockwise and increasing

GO ON TO THE NEXT PAGE.

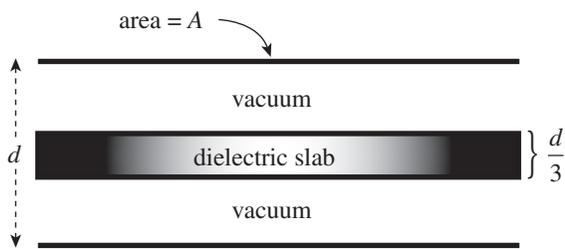

66. A dielectric of thickness $\frac{d}{3}$ is placed between the plates of a parallel-plate capacitor, as shown above. If K is the dielectric constant of the slab, what is the capacitance?

- (A) $\frac{\epsilon_0 A(2 + 3K)}{d}$
 (B) $\frac{d}{\epsilon_0 A(2 + 3K)}$
 (C) $\frac{3\epsilon_0 A}{d(2K + 1)}$
 (D) $\frac{3K\epsilon_0 A}{d(2K + 1)}$
 (E) $\frac{3K\epsilon_0 A}{d}$

+Q ●

○ -Q

67. Consider the two source charges shown above. At how many points in the plane of the page, in a region around these charges are both the electric field and the electric potential equal to zero?

- (A) 0
 (B) 1
 (C) 2
 (D) 3
 (E) 4

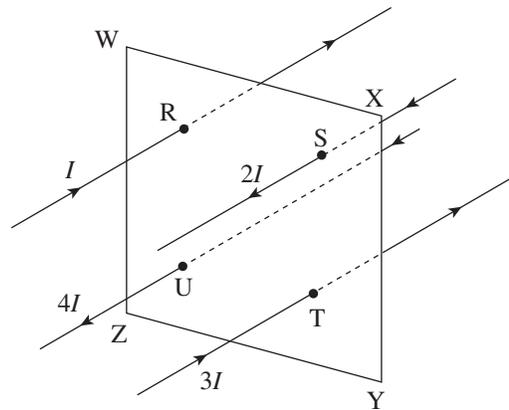

68. The figure above shows four current-carrying wires passing perpendicularly through the interior of a square whose vertices are W, X, Y, and Z. The points where the wires pierce the plane of the square (namely, R, S, T, and U) themselves form the vertices of a square each side of which has half the length of each side of WXYZ. If the currents are as labeled in the figure, what is the absolute value of

$$\oint \mathbf{B} \cdot d\ell$$

where the integral is taken around WXYZ?

- (A) $\frac{1}{2} \mu_0 I$
 (B) $\mu_0 I$
 (C) $\sqrt{2} \mu_0 I$
 (D) $2\mu_0 I$
 (E) $5\mu_0 I$

GO ON TO THE NEXT PAGE.

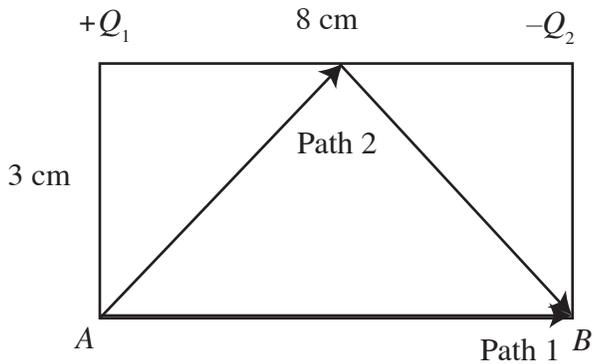

69. A particle with charge $+q$ is moved from point A to point B along path 1 in the picture above. Its change in potential energy is U . If a charge of $-q$ is then moved from A to B along path 2, its change in potential energy will be
- (A) $-\left(\frac{10}{8}\right)U$
 (B) $-U$
 (C) U
 (D) $\left(\frac{10}{8}\right)U$
 (E) Cannot be determined without knowing the values of Q_1 and Q_2

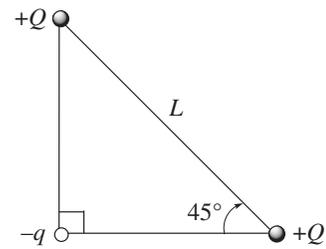

70. Two point charges, each $+Q$, are fixed a distance L apart. A particle of charge $-q$ and mass m is placed as shown in the figure above. What is this particle's initial acceleration when released from rest?
- (A) $\frac{\sqrt{2}Qq}{2\pi\epsilon_0 L^2 m}$
 (B) $\frac{\sqrt{2}Qq}{\pi\epsilon_0 L^2 m}$
 (C) $\frac{2Qq}{\pi\epsilon_0 L^2 m}$
 (D) $\frac{2\sqrt{2}Qq}{\pi\epsilon_0 L^2 m}$
 (E) $\frac{4Qq}{\pi\epsilon_0 L^2 m}$

STOP

END OF SECTION I, ELECTRICITY AND MAGNETISM

PHYSICS C
SECTION II, ELECTRICITY AND MAGNETISM
Time—45 minutes
3 Questions

Directions: Answer all three questions. The suggested time is about 15 minutes per question for answering each of the questions, which are worth 15 points each. The parts within a question may not have equal weight.

- E & M 1. A uniformly charged, nonconducting, circular ring of radius R carries a charge $+Q$. Its central axis is labeled the z -axis, and the center of the ring is $z = 0$. Points above the ring on the z -axis have positive z -coordinates; those below have negative z -coordinates.

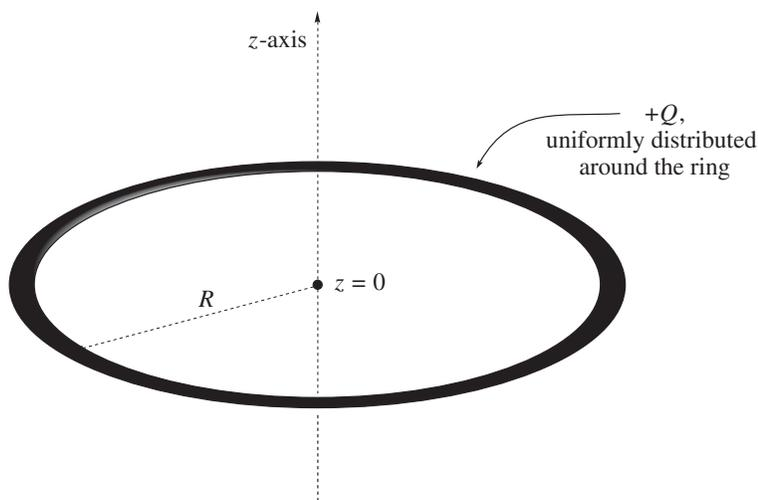

- (a) Calculate the electric potential at an arbitrary point on the z -axis. Write your answer in terms of Q , z , R , and fundamental constants.
- (b) (i) At what point(s) on the z -axis will the potential have its greatest value?
(ii) What is this maximum potential value?
- (c) Find an expression for the electric field (magnitude and direction) at an arbitrary point on the z -axis. Write your answer in terms of Q , z , R , and fundamental constants.
- (d) A positive charge is released from rest at $z = +2R$ on the z -axis. Describe the subsequent motion of the positive charge. Justify your answer.

GO ON TO THE NEXT PAGE.

E & M 2. In the circuit shown below, the capacitor is initially uncharged and there is no current in any circuit element.

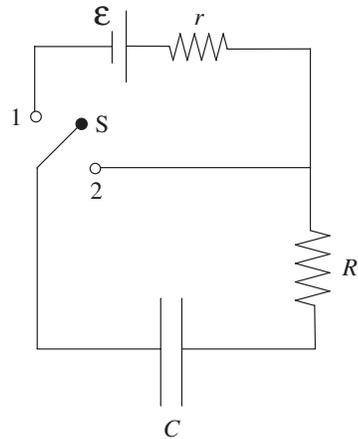

In each of the following, k is a number greater than 1; write each of your answers in terms of \mathcal{E} , r , R , C , k , and fundamental constants.

- (a) At $t = 0$, the switch S is moved to position 1.
- At what time t is the current through R equal to $\frac{1}{k}$ of its initial value?
 - At what time t is the charge on the capacitor equal to $\frac{1}{k}$ of its maximum value?
 - At what time t is the energy stored in the capacitor equal to $\frac{1}{k}$ of its maximum value?
- (b) After the switch has been at position 1 for a very long time, it is then moved to position 2. Let this redefine $t = 0$ for purposes of the following questions.
- How long will it take for the current through R to equal $\frac{1}{k}$ of its initial value?
 - At what time t is the charge on the capacitor equal to $\frac{1}{k}$ of its initial value?

GO ON TO THE NEXT PAGE.

- E & M 3. The diagram below shows two parallel conducting rails connected by a third rail of length L , raised to an angle of θ with the horizontal (supported by a pair of insulating columns). A metal strip of length L , mass m , and resistance R is free to slide without friction down the rails. The apparatus is immersed in a vertical, uniform magnetic field, \mathbf{B} . The resistance of the stationary rails may be neglected.

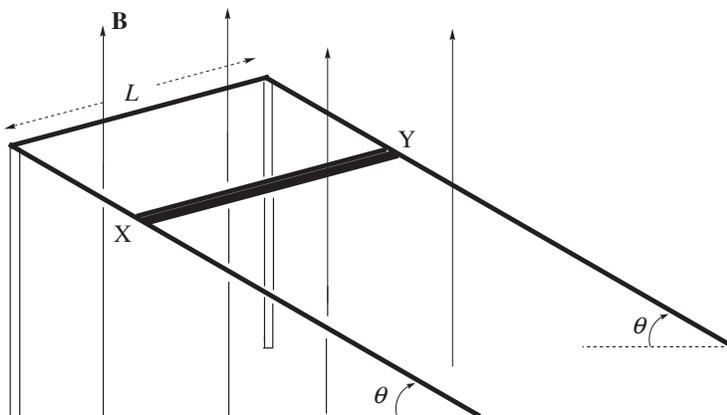

- (a) As the strip slides down the rails with instantaneous speed v , determine
- the magnitude of the induced emf. (Write your answer in terms of L , B , v , and θ .)
 - the direction of the induced current in the strip (X to Y, or Y to X?).
 - the magnitude of the induced current. (Write your answer in terms of L , B , R , v , and θ .)
- (b) The strip XY will eventually slide down the rails at a constant velocity. Derive an expression for this velocity in terms of L , B , R , m , g , and θ .
- (c) When the strip is sliding with the constant velocity determined in part (b), show that the power dissipation in the strip is equal to the rate at which gravity is doing work on the strip.

STOP

END OF EXAM

Completely darken bubbles with a No. 2 pencil. If you make a mistake, be sure to erase mark completely. Erase all stray marks.

1. YOUR NAME: _____
(Print) Last First M.I.

SIGNATURE: _____ DATE: ____/____/____

HOME ADDRESS: _____
(Print) Number and Street

City State Zip Code

PHONE NO.: _____

5. YOUR NAME

First 4 letters of last name				FIRST INIT	MID INIT
A	A	A	A	A	A
B	B	B	B	B	B
C	C	C	C	C	C
D	D	D	D	D	D
E	E	E	E	E	E
F	F	F	F	F	F
G	G	G	G	G	G
H	H	H	H	H	H
I	I	I	I	I	I
J	J	J	J	J	J
K	K	K	K	K	K
L	L	L	L	L	L
M	M	M	M	M	M
N	N	N	N	N	N
O	O	O	O	O	O
P	P	P	P	P	P
Q	Q	Q	Q	Q	Q
R	R	R	R	R	R
S	S	S	S	S	S
T	T	T	T	T	T
U	U	U	U	U	U
V	V	V	V	V	V
W	W	W	W	W	W
X	X	X	X	X	X
Y	Y	Y	Y	Y	Y
Z	Z	Z	Z	Z	Z

IMPORTANT: Please fill in these boxes exactly as shown on the back cover of your test book.

2. TEST FORM

3. TEST CODE				4. REGISTRATION NUMBER							
0	A	J	0	0	0	0	0	0	0	0	0
1	B	K	1	1	1	1	1	1	1	1	1
2	C	L	2	2	2	2	2	2	2	2	2
3	D	M	3	3	3	3	3	3	3	3	3
4	E	N	4	4	4	4	4	4	4	4	4
5	F	O	5	5	5	5	5	5	5	5	5
6	G	P	6	6	6	6	6	6	6	6	6
7	H	Q	7	7	7	7	7	7	7	7	7
8	I	R	8	8	8	8	8	8	8	8	8
9			9	9	9	9	9	9	9	9	9

6. DATE OF BIRTH

Month	Day		Year	
<input type="radio"/> JAN				
<input type="radio"/> FEB	0	0	0	0
<input type="radio"/> MAR	1	1	1	1
<input type="radio"/> APR	2	2	2	2
<input type="radio"/> MAY	3	3	3	3
<input type="radio"/> JUN		4	4	4
<input type="radio"/> JUL		5	5	5
<input type="radio"/> AUG		6	6	6
<input type="radio"/> SEP		7	7	7
<input type="radio"/> OCT		8	8	8
<input type="radio"/> NOV		9	9	9
<input type="radio"/> DEC				

7. GENDER

MALE

FEMALE



1. <input type="radio"/> A <input type="radio"/> B <input type="radio"/> C <input type="radio"/> D <input type="radio"/> E	19. <input type="radio"/> A <input type="radio"/> B <input type="radio"/> C <input type="radio"/> D <input type="radio"/> E	37. <input type="radio"/> A <input type="radio"/> B <input type="radio"/> C <input type="radio"/> D <input type="radio"/> E	55. <input type="radio"/> A <input type="radio"/> B <input type="radio"/> C <input type="radio"/> D <input type="radio"/> E
2. <input type="radio"/> A <input type="radio"/> B <input type="radio"/> C <input type="radio"/> D <input type="radio"/> E	20. <input type="radio"/> A <input type="radio"/> B <input type="radio"/> C <input type="radio"/> D <input type="radio"/> E	38. <input type="radio"/> A <input type="radio"/> B <input type="radio"/> C <input type="radio"/> D <input type="radio"/> E	56. <input type="radio"/> A <input type="radio"/> B <input type="radio"/> C <input type="radio"/> D <input type="radio"/> E
3. <input type="radio"/> A <input type="radio"/> B <input type="radio"/> C <input type="radio"/> D <input type="radio"/> E	21. <input type="radio"/> A <input type="radio"/> B <input type="radio"/> C <input type="radio"/> D <input type="radio"/> E	39. <input type="radio"/> A <input type="radio"/> B <input type="radio"/> C <input type="radio"/> D <input type="radio"/> E	57. <input type="radio"/> A <input type="radio"/> B <input type="radio"/> C <input type="radio"/> D <input type="radio"/> E
4. <input type="radio"/> A <input type="radio"/> B <input type="radio"/> C <input type="radio"/> D <input type="radio"/> E	22. <input type="radio"/> A <input type="radio"/> B <input type="radio"/> C <input type="radio"/> D <input type="radio"/> E	40. <input type="radio"/> A <input type="radio"/> B <input type="radio"/> C <input type="radio"/> D <input type="radio"/> E	58. <input type="radio"/> A <input type="radio"/> B <input type="radio"/> C <input type="radio"/> D <input type="radio"/> E
5. <input type="radio"/> A <input type="radio"/> B <input type="radio"/> C <input type="radio"/> D <input type="radio"/> E	23. <input type="radio"/> A <input type="radio"/> B <input type="radio"/> C <input type="radio"/> D <input type="radio"/> E	41. <input type="radio"/> A <input type="radio"/> B <input type="radio"/> C <input type="radio"/> D <input type="radio"/> E	59. <input type="radio"/> A <input type="radio"/> B <input type="radio"/> C <input type="radio"/> D <input type="radio"/> E
6. <input type="radio"/> A <input type="radio"/> B <input type="radio"/> C <input type="radio"/> D <input type="radio"/> E	24. <input type="radio"/> A <input type="radio"/> B <input type="radio"/> C <input type="radio"/> D <input type="radio"/> E	42. <input type="radio"/> A <input type="radio"/> B <input type="radio"/> C <input type="radio"/> D <input type="radio"/> E	60. <input type="radio"/> A <input type="radio"/> B <input type="radio"/> C <input type="radio"/> D <input type="radio"/> E
7. <input type="radio"/> A <input type="radio"/> B <input type="radio"/> C <input type="radio"/> D <input type="radio"/> E	25. <input type="radio"/> A <input type="radio"/> B <input type="radio"/> C <input type="radio"/> D <input type="radio"/> E	43. <input type="radio"/> A <input type="radio"/> B <input type="radio"/> C <input type="radio"/> D <input type="radio"/> E	61. <input type="radio"/> A <input type="radio"/> B <input type="radio"/> C <input type="radio"/> D <input type="radio"/> E
8. <input type="radio"/> A <input type="radio"/> B <input type="radio"/> C <input type="radio"/> D <input type="radio"/> E	26. <input type="radio"/> A <input type="radio"/> B <input type="radio"/> C <input type="radio"/> D <input type="radio"/> E	44. <input type="radio"/> A <input type="radio"/> B <input type="radio"/> C <input type="radio"/> D <input type="radio"/> E	62. <input type="radio"/> A <input type="radio"/> B <input type="radio"/> C <input type="radio"/> D <input type="radio"/> E
9. <input type="radio"/> A <input type="radio"/> B <input type="radio"/> C <input type="radio"/> D <input type="radio"/> E	27. <input type="radio"/> A <input type="radio"/> B <input type="radio"/> C <input type="radio"/> D <input type="radio"/> E	45. <input type="radio"/> A <input type="radio"/> B <input type="radio"/> C <input type="radio"/> D <input type="radio"/> E	63. <input type="radio"/> A <input type="radio"/> B <input type="radio"/> C <input type="radio"/> D <input type="radio"/> E
10. <input type="radio"/> A <input type="radio"/> B <input type="radio"/> C <input type="radio"/> D <input type="radio"/> E	28. <input type="radio"/> A <input type="radio"/> B <input type="radio"/> C <input type="radio"/> D <input type="radio"/> E	46. <input type="radio"/> A <input type="radio"/> B <input type="radio"/> C <input type="radio"/> D <input type="radio"/> E	64. <input type="radio"/> A <input type="radio"/> B <input type="radio"/> C <input type="radio"/> D <input type="radio"/> E
11. <input type="radio"/> A <input type="radio"/> B <input type="radio"/> C <input type="radio"/> D <input type="radio"/> E	29. <input type="radio"/> A <input type="radio"/> B <input type="radio"/> C <input type="radio"/> D <input type="radio"/> E	47. <input type="radio"/> A <input type="radio"/> B <input type="radio"/> C <input type="radio"/> D <input type="radio"/> E	65. <input type="radio"/> A <input type="radio"/> B <input type="radio"/> C <input type="radio"/> D <input type="radio"/> E
12. <input type="radio"/> A <input type="radio"/> B <input type="radio"/> C <input type="radio"/> D <input type="radio"/> E	30. <input type="radio"/> A <input type="radio"/> B <input type="radio"/> C <input type="radio"/> D <input type="radio"/> E	48. <input type="radio"/> A <input type="radio"/> B <input type="radio"/> C <input type="radio"/> D <input type="radio"/> E	66. <input type="radio"/> A <input type="radio"/> B <input type="radio"/> C <input type="radio"/> D <input type="radio"/> E
13. <input type="radio"/> A <input type="radio"/> B <input type="radio"/> C <input type="radio"/> D <input type="radio"/> E	31. <input type="radio"/> A <input type="radio"/> B <input type="radio"/> C <input type="radio"/> D <input type="radio"/> E	49. <input type="radio"/> A <input type="radio"/> B <input type="radio"/> C <input type="radio"/> D <input type="radio"/> E	67. <input type="radio"/> A <input type="radio"/> B <input type="radio"/> C <input type="radio"/> D <input type="radio"/> E
14. <input type="radio"/> A <input type="radio"/> B <input type="radio"/> C <input type="radio"/> D <input type="radio"/> E	32. <input type="radio"/> A <input type="radio"/> B <input type="radio"/> C <input type="radio"/> D <input type="radio"/> E	50. <input type="radio"/> A <input type="radio"/> B <input type="radio"/> C <input type="radio"/> D <input type="radio"/> E	68. <input type="radio"/> A <input type="radio"/> B <input type="radio"/> C <input type="radio"/> D <input type="radio"/> E
15. <input type="radio"/> A <input type="radio"/> B <input type="radio"/> C <input type="radio"/> D <input type="radio"/> E	33. <input type="radio"/> A <input type="radio"/> B <input type="radio"/> C <input type="radio"/> D <input type="radio"/> E	51. <input type="radio"/> A <input type="radio"/> B <input type="radio"/> C <input type="radio"/> D <input type="radio"/> E	69. <input type="radio"/> A <input type="radio"/> B <input type="radio"/> C <input type="radio"/> D <input type="radio"/> E
16. <input type="radio"/> A <input type="radio"/> B <input type="radio"/> C <input type="radio"/> D <input type="radio"/> E	34. <input type="radio"/> A <input type="radio"/> B <input type="radio"/> C <input type="radio"/> D <input type="radio"/> E	52. <input type="radio"/> A <input type="radio"/> B <input type="radio"/> C <input type="radio"/> D <input type="radio"/> E	70. <input type="radio"/> A <input type="radio"/> B <input type="radio"/> C <input type="radio"/> D <input type="radio"/> E
17. <input type="radio"/> A <input type="radio"/> B <input type="radio"/> C <input type="radio"/> D <input type="radio"/> E	35. <input type="radio"/> A <input type="radio"/> B <input type="radio"/> C <input type="radio"/> D <input type="radio"/> E	53. <input type="radio"/> A <input type="radio"/> B <input type="radio"/> C <input type="radio"/> D <input type="radio"/> E	
18. <input type="radio"/> A <input type="radio"/> B <input type="radio"/> C <input type="radio"/> D <input type="radio"/> E	36. <input type="radio"/> A <input type="radio"/> B <input type="radio"/> C <input type="radio"/> D <input type="radio"/> E	54. <input type="radio"/> A <input type="radio"/> B <input type="radio"/> C <input type="radio"/> D <input type="radio"/> E	

PRACTICE TEST 1 ANSWER KEY

Mechanics

Question Number	Question Answer	Correct? 	See Chapter(s) #
1	E		Chapter 5
2	E		Chapter 5
3	A		Chapter 5
4	B		Chapter 9
5	C		Chapters 6, 9
6	A		Chapter 10
7	C		Chapters 7, 11
8	D		Chapters 6, 9
9	B		Chapters 5, 6
10	B		Chapters 6, 7
11	A		Chapters 7, 10
12	D		Chapters 6, 9
13	C		Chapters 7, 8
14	D		Chapter 9
15	C		Chapters 5, 7
16	A		Chapter 11
17	C		Chapter 9
18	B		Chapter 6
19	D		Chapters 6, 9
20	B		Chapter 10
21	C		Chapter 7
22	C		Chapter 9
23	C		Chapters 4, 5
24	B		Chapter 12
25	D		Chapters 4, 8
26	B		Chapters 6, 11
27	D		Chapters 5, 7
28	D		Chapter 9
29	A		Chapter 7
30	B		Chapters 6, 11
31	D		Chapter 9
32	E		Chapter 7
33	D		Chapter 6
34	B		Chapter 7
35	E		Chapter 6

Question Number	Question Answer	Correct? 	See Chapter(s) #
1(a)	*		Chapter 5
1(b)	*		Chapters 4, 5
1(c)	*		Chapters 4, 5
1(d)	*		Chapters 4, 5
1(e)	*		Chapters 4, 5
2(a)	*		Chapter 10
2(b)	*		Chapter 7
2(c)	*		Chapter 7
2(d)(i)	*		Chapter 7
2(d)(ii)	*		Chapter 7
3(a)(i)	*		Chapters 8, 9
3(a)(ii)	*		Chapters 8, 9
3(a)(iii)	*		Chapters 8, 9
3(b)	*		Chapters 7, 9

*See explanations beginning on page 53.

Electricity and Magnetism

Question Number	Question Answer	Correct? 	See Chapter(s) #
36	C		Chapter 12
37	B		Chapter 13
38	E		Chapter 15
39	A		Chapter 12
40	B		Chapter 14
41	E		Chapter 15
42	C		Chapter 12
43	C		Chapters 12, 13
44	A		Chapter 12
45	E		Chapter 14
46	E		Chapter 14
47	D		Chapters 13, 14
48	B		Chapter 16
49	A		Chapter 16
50	D		Chapter 12
51	A		Chapter 15
52	A		Chapter 12
53	C		Chapter 13
54	E		Chapter 16
55	E		Chapter 12
56	E		Chapter 13
57	C		Chapter 15
58	B		Chapter 14
59	B		Chapter 14
60	A		Chapter 14
61	C		Chapter 12
62	B		Chapter 13
63	E		Chapter 16
64	E		Chapter 14
65	D		Chapter 16
66	D		Chapter 13
67	A		Chapters 12, 13
68	D		Chapter 15
69	B		Chapter 13
70	A		Chapters 6, 12

Question Number	Question Answer	Correct? 	See Chapter(s) #
1(a)	*		Chapter 13
1(b)	*		Chapter 13
1(b)(i)	*		Chapter 13
1(b)(ii)	*		Chapter 13
1(c)	*		Chapter 13
1(d)	*		Chapters 6, 12
2(a)(i)	*		Chapters 13, 14
2(a)(ii)	*		Chapters 13, 14
2(a)(iii)	*		Chapters 13, 14
2(b)(i)	*		Chapters 13, 14
2(b)(ii)	*		Chapters 13, 14
3(a)(i)	*		Chapter 16
3(a)(ii)	*		Chapter 16
3(a)(iii)	*		Chapter 16
3(b)	*		Chapter 16
3(c)	*		Chapter 16

*See explanations beginning on page 68.

MECHANICS PRACTICE TEST 1 DIAGNOSTIC

CHAPTER 4 TEST SCORE SELF-EVALUATION

$$\frac{\begin{array}{|c|} \hline \text{\# WRONG QUESTIONS} \\ \hline \boxed{} \\ \hline \end{array}}{\begin{array}{|c|} \hline \text{\# TOTAL QUESTIONS} \\ \hline \boxed{6} \\ \hline \end{array}} = \frac{\boxed{}}{\text{YOUR SCORE}} \%$$

CHAPTER 9 TEST SCORE SELF-EVALUATION

$$\frac{\begin{array}{|c|} \hline \text{\# WRONG QUESTIONS} \\ \hline \boxed{} \\ \hline \end{array}}{\begin{array}{|c|} \hline \text{\# TOTAL QUESTIONS} \\ \hline \boxed{14} \\ \hline \end{array}} = \frac{\boxed{}}{\text{YOUR SCORE}} \%$$

CHAPTER 5 TEST SCORE SELF-EVALUATION

$$\frac{\begin{array}{|c|} \hline \text{\# WRONG QUESTIONS} \\ \hline \boxed{} \\ \hline \end{array}}{\begin{array}{|c|} \hline \text{\# TOTAL QUESTIONS} \\ \hline \boxed{12} \\ \hline \end{array}} = \frac{\boxed{}}{\text{YOUR SCORE}} \%$$

CHAPTER 10 TEST SCORE SELF-EVALUATION

$$\frac{\begin{array}{|c|} \hline \text{\# WRONG QUESTIONS} \\ \hline \boxed{} \\ \hline \end{array}}{\begin{array}{|c|} \hline \text{\# TOTAL QUESTIONS} \\ \hline \boxed{4} \\ \hline \end{array}} = \frac{\boxed{}}{\text{YOUR SCORE}} \%$$

CHAPTER 6 TEST SCORE SELF-EVALUATION

$$\frac{\begin{array}{|c|} \hline \text{\# WRONG QUESTIONS} \\ \hline \boxed{} \\ \hline \end{array}}{\begin{array}{|c|} \hline \text{\# TOTAL QUESTIONS} \\ \hline \boxed{11} \\ \hline \end{array}} = \frac{\boxed{}}{\text{YOUR SCORE}} \%$$

CHAPTER 11 TEST SCORE SELF-EVALUATION

$$\frac{\begin{array}{|c|} \hline \text{\# WRONG QUESTIONS} \\ \hline \boxed{} \\ \hline \end{array}}{\begin{array}{|c|} \hline \text{\# TOTAL QUESTIONS} \\ \hline \boxed{4} \\ \hline \end{array}} = \frac{\boxed{}}{\text{YOUR SCORE}} \%$$

CHAPTER 7 TEST SCORE SELF-EVALUATION

$$\frac{\begin{array}{|c|} \hline \text{\# WRONG QUESTIONS} \\ \hline \boxed{} \\ \hline \end{array}}{\begin{array}{|c|} \hline \text{\# TOTAL QUESTIONS} \\ \hline \boxed{15} \\ \hline \end{array}} = \frac{\boxed{}}{\text{YOUR SCORE}} \%$$

CHAPTER 12 TEST SCORE SELF-EVALUATION

$$\frac{\begin{array}{|c|} \hline \text{\# WRONG QUESTIONS} \\ \hline \boxed{} \\ \hline \end{array}}{\begin{array}{|c|} \hline \text{\# TOTAL QUESTIONS} \\ \hline \boxed{1} \\ \hline \end{array}} = \frac{\boxed{}}{\text{YOUR SCORE}} \%$$

CHAPTER 8 TEST SCORE SELF-EVALUATION

$$\frac{\begin{array}{|c|} \hline \text{\# WRONG QUESTIONS} \\ \hline \boxed{} \\ \hline \end{array}}{\begin{array}{|c|} \hline \text{\# TOTAL QUESTIONS} \\ \hline \boxed{5} \\ \hline \end{array}} = \frac{\boxed{}}{\text{YOUR SCORE}} \%$$

ELECTRICITY AND MAGNETISM PRACTICE TEST 1 DIAGNOSTIC

CHAPTER 6 TEST SCORE SELF-EVALUATION

$$\frac{\begin{array}{|c|} \hline \# \text{ WRONG QUESTIONS} \\ \hline \square \\ \hline \end{array}}{\begin{array}{|c|} \hline \# \text{ TOTAL QUESTIONS} \\ \hline \mathbf{2} \\ \hline \end{array}} = \begin{array}{|c|} \hline \square \\ \hline \text{YOUR SCORE} \\ \hline \end{array} \%$$

CHAPTER 14 TEST SCORE SELF-EVALUATION

$$\frac{\begin{array}{|c|} \hline \# \text{ WRONG QUESTIONS} \\ \hline \square \\ \hline \end{array}}{\begin{array}{|c|} \hline \# \text{ TOTAL QUESTIONS} \\ \hline \mathbf{13} \\ \hline \end{array}} = \begin{array}{|c|} \hline \square \\ \hline \text{YOUR SCORE} \\ \hline \end{array} \%$$

CHAPTER 12 TEST SCORE SELF-EVALUATION

$$\frac{\begin{array}{|c|} \hline \# \text{ WRONG QUESTIONS} \\ \hline \square \\ \hline \end{array}}{\begin{array}{|c|} \hline \# \text{ TOTAL QUESTIONS} \\ \hline \mathbf{12} \\ \hline \end{array}} = \begin{array}{|c|} \hline \square \\ \hline \text{YOUR SCORE} \\ \hline \end{array} \%$$

CHAPTER 15 TEST SCORE SELF-EVALUATION

$$\frac{\begin{array}{|c|} \hline \# \text{ WRONG QUESTIONS} \\ \hline \square \\ \hline \end{array}}{\begin{array}{|c|} \hline \# \text{ TOTAL QUESTIONS} \\ \hline \mathbf{5} \\ \hline \end{array}} = \begin{array}{|c|} \hline \square \\ \hline \text{YOUR SCORE} \\ \hline \end{array} \%$$

CHAPTER 13 TEST SCORE SELF-EVALUATION

$$\frac{\begin{array}{|c|} \hline \# \text{ WRONG QUESTIONS} \\ \hline \square \\ \hline \end{array}}{\begin{array}{|c|} \hline \# \text{ TOTAL QUESTIONS} \\ \hline \mathbf{18} \\ \hline \end{array}} = \begin{array}{|c|} \hline \square \\ \hline \text{YOUR SCORE} \\ \hline \end{array} \%$$

CHAPTER 16 TEST SCORE SELF-EVALUATION

$$\frac{\begin{array}{|c|} \hline \# \text{ WRONG QUESTIONS} \\ \hline \square \\ \hline \end{array}}{\begin{array}{|c|} \hline \# \text{ TOTAL QUESTIONS} \\ \hline \mathbf{10} \\ \hline \end{array}} = \begin{array}{|c|} \hline \square \\ \hline \text{YOUR SCORE} \\ \hline \end{array} \%$$