

Chapter 14 Drill

The answers and explanations can be found in Chapter 17.

Section I: Multiple Choice

1. A wire made of brass and a wire made of silver have the same length, but the diameter of the brass wire is 4 times the diameter of the silver wire. The resistivity of brass is 5 times greater than the resistivity of silver. If R_B denotes the resistance of the brass wire and R_S denotes the resistance of the silver wire, which of the following is true?

- (A) $R_B = \frac{5}{16} R_S$
 (B) $R_B = \frac{4}{5} R_S$
 (C) $R_B = \frac{5}{4} R_S$
 (D) $R_B = \frac{5}{2} R_S$
 (E) $R_B = \frac{16}{5} R_S$

2. For an ohmic conductor, doubling the voltage without changing the resistance will cause the current to

- (A) decrease by a factor of 4
 (B) decrease by a factor of 2
 (C) remain unchanged
 (D) increase by a factor of 2
 (E) increase by a factor of 4

3. A given circuit uses 125 watts of power. If the circuit has a total resistance of 5Ω , at what voltage must it be operating?

- (A) 5 V
 (B) 15 V
 (C) 25 V
 (D) 45 V
 (E) 625 V

4. A battery whose emf is 40 V has an internal resistance of 5Ω . If this battery is connected to a 15Ω resistor R , what will the voltage drop across R be?

- (A) 10 V
 (B) 30 V
 (C) 40 V
 (D) 50 V
 (E) 70 V

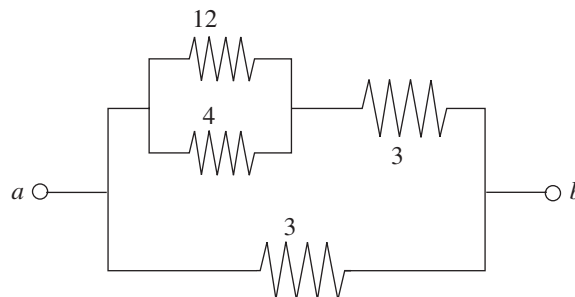

5. Determine the equivalent resistance between points a and b in the figure above.

- (A) 0.167Ω
 (B) 0.25Ω
 (C) 0.333Ω
 (D) 1.5Ω
 (E) 2Ω

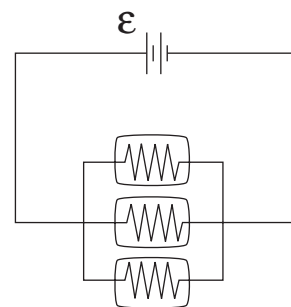

6. Three identical light bulbs are connected to a source of emf, as shown in the diagram above. What will happen if the middle bulb burns out?

- (A) All the bulbs will go out.
 (B) The light intensity of the other two bulbs will decrease (but they won't go out).
 (C) The light intensity of the other two bulbs will increase.
 (D) The light intensity of the other two bulbs will remain the same.
 (E) More current will be drawn from the source of emf.

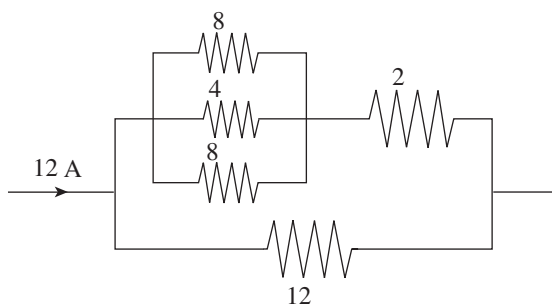

7. What is the voltage drop across the 12-ohm resistor in the portion of the circuit shown above?

- (A) 24 V
- (B) 36 V
- (C) 48 V
- (D) 72 V
- (E) 144 V

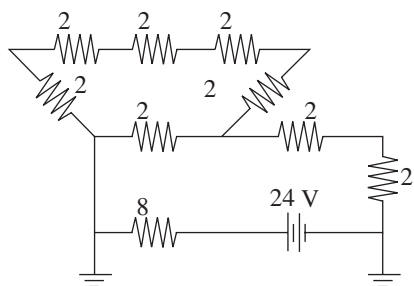

8. What is the current through the 8-ohm resistor in the circuit shown above?

- (A) 0.5 A
- (B) 1.0 A
- (C) 1.25 A
- (D) 1.5 A
- (E) 3.0 A

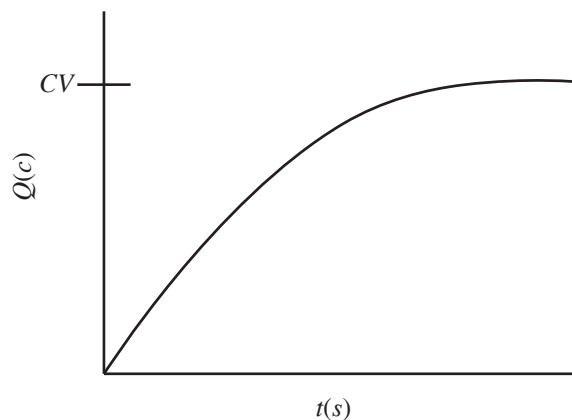

9. The graph above shows the charge vs. time for an RC circuit with voltage V and capacitance C . The slope of this graph represents

- (A) the total charge on the capacitor plates
- (B) the potential energy of the capacitor
- (C) the resistance of the circuit
- (D) the instantaneous voltage of the capacitor
- (E) the instantaneous current of the circuit

10. Which of the following combinations of values for total resistance, R , and capacitance, C , would produce an RC circuit that reached its maximum charge (on the capacitor) most quickly?

- (A) $R = 4 \Omega$; $C = 20 \mu\text{F}$
- (B) $R = 6 \Omega$; $C = 25 \mu\text{F}$
- (C) $R = 8 \Omega$; $C = 30 \mu\text{F}$
- (D) $R = 4 \Omega$; $C = 35 \mu\text{F}$
- (E) $R = 8 \Omega$; $C = 40 \mu\text{F}$

Section II: Free Response

1. Consider the following circuit:

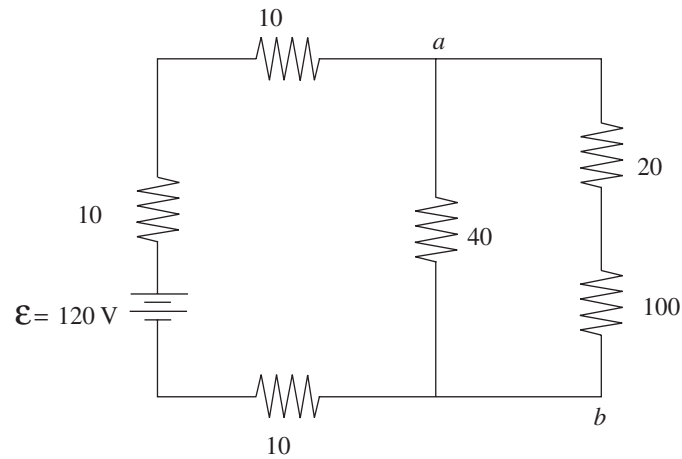

- At what rate does the battery deliver energy to the circuit?
- Find the current through the $20\ \Omega$ resistor.
- Determine the potential difference between points a and b .
 - At which of these two points is the potential higher?
- Find the energy dissipated by the $100\ \Omega$ resistor in 10 s.
- Given that the $100\ \Omega$ resistor is a solid cylinder that's 4 cm long, composed of a material whose resistivity is $0.45\ \Omega\cdot\text{m}$, determine its radius.

2. The diagram below shows an uncharged capacitor, two resistors, and a battery whose emf is ϵ .

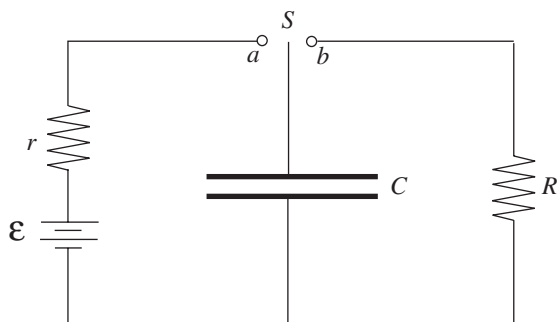

The switch S is turned to point a at time $t = 0$.

(Express all answers in terms of C , r , R , ϵ , and fundamental constants.)

- (a) Determine the current through r at time $t = 0$.
- (b) Compute the time required for the charge on the capacitor to reach one-half its final value.
- (c) When the capacitor is fully charged, which plate is positively charged?
- (d) Determine the electrical potential energy stored in the capacitor when the current through r is zero.

When the current through r is zero, the switch S is then moved to Point b ; for the following parts, consider this event time $t = 0$.

- (e) Determine the current through R as a function of time.
- (f) Find the power dissipated in R as a function of time.
- (g) Determine the total amount of energy dissipated as heat by R .