



Chapter 30  
Practice Exam 3



# ACT Diagnostic Test Form

Use a No. 2 pencil only. Be sure each mark is dark and completely fills the intended oval. Completely erase any errors or stray marks.

1. YOUR NAME: \_\_\_\_\_  
(Print) Last First M.I.

SIGNATURE: \_\_\_\_\_ DATE: \_\_\_\_/\_\_\_\_/\_\_\_\_

HOME ADDRESS: \_\_\_\_\_  
(Print) Number and Street  
 \_\_\_\_\_  
City State Zip

3. TEST CODE			
0	0	0	0
1	1	1	1
2	2	2	2
3	3	3	3
4	4	4	4
5	5	5	5
6	6	6	6
7	7	7	7
8	8	8	8
9	9	9	9

E-MAIL: \_\_\_\_\_

PHONE NO.: \_\_\_\_\_  
(Print)

SCHOOL: \_\_\_\_\_

CLASS OF: \_\_\_\_\_

IMPORTANT: Please fill in these boxes exactly as shown on the back cover of your test book.

2. TEST FORM
_____

4. PHONE NUMBER						
0	0	0	0	0	0	0
1	1	1	1	1	1	1
2	2	2	2	2	2	2
3	3	3	3	3	3	3
4	4	4	4	4	4	4
5	5	5	5	5	5	5
6	6	6	6	6	6	6
7	7	7	7	7	7	7
8	8	8	8	8	8	8
9	9	9	9	9	9	9

5. YOUR NAME					
First 4 letters of last name				FIRST INIT	MID INIT
A	A	A	A	A	A
B	B	B	B	B	B
C	C	C	C	C	C
D	D	D	D	D	D
E	E	E	E	E	E
F	F	F	F	F	F
G	G	G	G	G	G
H	H	H	H	H	H
I	I	I	I	I	I
J	J	J	J	J	J
K	K	K	K	K	K
L	L	L	L	L	L
M	M	M	M	M	M
N	N	N	N	N	N
O	O	O	O	O	O
P	P	P	P	P	P
Q	Q	Q	Q	Q	Q
R	R	R	R	R	R
S	S	S	S	S	S
T	T	T	T	T	T
U	U	U	U	U	U
V	V	V	V	V	V
W	W	W	W	W	W
X	X	X	X	X	X
Y	Y	Y	Y	Y	Y
Z	Z	Z	Z	Z	Z

6. DATE OF BIRTH			
MONTH	DAY		YEAR
<input type="radio"/> JAN			
<input type="radio"/> FEB			
<input type="radio"/> MAR	0	0	0
<input type="radio"/> APR	1	1	1
<input type="radio"/> MAY	2	2	2
<input type="radio"/> JUN	3	3	3
<input type="radio"/> JUL		4	4
<input type="radio"/> AUG		5	5
<input type="radio"/> SEP		6	6
<input type="radio"/> OCT		7	7
<input type="radio"/> NOV		8	8
<input type="radio"/> DEC		9	9

7. SEX
<input type="radio"/> MALE
<input type="radio"/> FEMALE

8. OTHER	
1	A B C D E
2	A B C D E
3	A B C D E

# The Princeton Review Diagnostic ACT Form

Completely darken bubbles with a No. 2 pencil. If you make a mistake, be sure to erase mark completely. Erase all stray marks.

## ENGLISH

1	A	B	C	D	21	A	B	C	D	41	A	B	C	D	61	A	B	C	D
2	F	G	H	J	22	F	G	H	J	42	F	G	H	J	62	F	G	H	J
3	A	B	C	D	23	A	B	C	D	43	A	B	C	D	63	A	B	C	D
4	F	G	H	J	24	F	G	H	J	44	F	G	H	J	64	F	G	H	J
5	A	B	C	D	25	A	B	C	D	45	A	B	C	D	65	A	B	C	D
6	F	G	H	J	26	F	G	H	J	46	F	G	H	J	66	F	G	H	J
7	A	B	C	D	27	A	B	C	D	47	A	B	C	D	67	A	B	C	D
8	F	G	H	J	28	F	G	H	J	48	F	G	H	J	68	F	G	H	J
9	A	B	C	D	29	A	B	C	D	49	A	B	C	D	69	A	B	C	D
10	F	G	H	J	30	F	G	H	J	50	F	G	H	J	70	F	G	H	J
11	A	B	C	D	31	A	B	C	D	51	A	B	C	D	71	A	B	C	D
12	F	G	H	J	32	F	G	H	J	52	F	G	H	J	72	F	G	H	J
13	A	B	C	D	33	A	B	C	D	53	A	B	C	D	73	A	B	C	D
14	F	G	H	J	34	F	G	H	J	54	F	G	H	J	74	F	G	H	J
15	A	B	C	D	35	A	B	C	D	55	A	B	C	D	75	A	B	C	D
16	F	G	H	J	36	F	G	H	J	56	F	G	H	J					
17	A	B	C	D	37	A	B	C	D	57	A	B	C	D					
18	F	G	H	J	38	F	G	H	J	58	F	G	H	J					
19	A	B	C	D	39	A	B	C	D	59	A	B	C	D					
20	F	G	H	J	40	F	G	H	J	60	F	G	H	J					

## MATHEMATICS

1	A	B	C	D	E	16	F	G	H	J	K	31	A	B	C	D	E	46	F	G	H	J	K
2	F	G	H	J	K	17	A	B	C	D	E	32	F	G	H	J	K	47	A	B	C	D	E
3	A	B	C	D	E	18	F	G	H	J	K	33	A	B	C	D	E	48	F	G	H	J	K
4	F	G	H	J	K	19	A	B	C	D	E	34	F	G	H	J	K	49	A	B	C	D	E
5	A	B	C	D	E	20	F	G	H	J	K	35	A	B	C	D	E	50	F	G	H	J	K
6	F	G	H	J	K	21	A	B	C	D	E	36	F	G	H	J	K	51	A	B	C	D	E
7	A	B	C	D	E	22	F	G	H	J	K	37	A	B	C	D	E	52	F	G	H	J	K
8	F	G	H	J	K	23	A	B	C	D	E	38	F	G	H	J	K	53	A	B	C	D	E
9	A	B	C	D	E	24	F	G	H	J	K	39	A	B	C	D	E	54	F	G	H	J	K
10	F	G	H	J	K	25	A	B	C	D	E	40	F	G	H	J	K	55	A	B	C	D	E
11	A	B	C	D	E	26	F	G	H	J	K	41	A	B	C	D	E	56	F	G	H	J	K
12	F	G	H	J	K	27	A	B	C	D	E	42	F	G	H	J	K	57	A	B	C	D	E
13	A	B	C	D	E	28	F	G	H	J	K	43	A	B	C	D	E	58	F	G	H	J	K
14	F	G	H	J	K	29	A	B	C	D	E	44	F	G	H	J	K	59	A	B	C	D	E
15	A	B	C	D	E	30	F	G	H	J	K	45	A	B	C	D	E	60	F	G	H	J	K

# The Princeton Review Diagnostic ACT Form

Completely darken bubbles with a No. 2 pencil. If you make a mistake, be sure to erase mark completely. Erase all stray marks.

## READING

1	A	B	C	D	11	A	B	C	D	21	A	B	C	D	31	A	B	C	D
2	F	G	H	J	12	F	G	H	J	22	F	G	H	J	32	F	G	H	J
3	A	B	C	D	13	A	B	C	D	23	A	B	C	D	33	A	B	C	D
4	F	G	H	J	14	F	G	H	J	24	F	G	H	J	34	F	G	H	J
5	A	B	C	D	15	A	B	C	D	25	A	B	C	D	35	A	B	C	D
6	F	G	H	J	16	F	G	H	J	26	F	G	H	J	36	F	G	H	J
7	A	B	C	D	17	A	B	C	D	27	A	B	C	D	37	A	B	C	D
8	F	G	H	J	18	F	G	H	J	28	F	G	H	J	38	F	G	H	J
9	A	B	C	D	19	A	B	C	D	29	A	B	C	D	39	A	B	C	D
10	F	G	H	J	20	F	G	H	J	30	F	G	H	J	40	F	G	H	J

## SCIENCE REASONING

1	A	B	C	D	11	A	B	C	D	21	A	B	C	D	31	A	B	C	D
2	F	G	H	J	12	F	G	H	J	22	F	G	H	J	32	F	G	H	J
3	A	B	C	D	13	A	B	C	D	23	A	B	C	D	33	A	B	C	D
4	F	G	H	J	14	F	G	H	J	24	F	G	H	J	34	F	G	H	J
5	A	B	C	D	15	A	B	C	D	25	A	B	C	D	35	A	B	C	D
6	F	G	H	J	16	F	G	H	J	26	F	G	H	J	36	F	G	H	J
7	A	B	C	D	17	A	B	C	D	27	A	B	C	D	37	A	B	C	D
8	F	G	H	J	18	F	G	H	J	28	F	G	H	J	38	F	G	H	J
9	A	B	C	D	19	A	B	C	D	29	A	B	C	D	39	A	B	C	D
10	F	G	H	J	20	F	G	H	J	30	F	G	H	J	40	F	G	H	J

I hereby certify that I have truthfully identified myself on this form. I accept the consequences of falsifying my identity.

\_\_\_\_\_  
Your signature

\_\_\_\_\_  
Today's date









him home and was blocking his way. In my imagination

6. F. NO CHANGE  
 G. blocking  
 H. were blocking  
 J. DELETE the underlined portion.

he didn't look scared so much as frustrated.

7. At this point, the author would like to give the reader a better idea of how she thought her father felt. Given that all the choices are true, which one best accomplishes this purpose?  
 A. NO CHANGE  
 B. he was stuck on the highway for hours and hours.  
 C. he couldn't see the rats even though I could.  
 D. he looked so small compared to the giant rats.

I finally asked my father why he wanted us to move so far  
away from home. One of his main reasons, he said, was the long

8. Given that all the choices are true, which one provides the best opening to this paragraph?  
 F. NO CHANGE  
 G. The rats seemed like more of an annoyance than a danger.  
 H. I didn't really understand what my mom meant by the "rat race" until years later.  
 J. During holidays and long weekends, my father loved to go fishing.

drive home after work. For him, the worst and most terrible thing,  
 about living in Southern California was having no time to go  
 fishing, one of his favorite hobbies.

9. A. NO CHANGE  
 B. most awfully terrible part  
 C. worst, most terrible thing  
 D. worst part

[1] My parents eventually picked Redding for our new home, partly because there were two lakes within an hour's drive, and we made the move. [2] Since my father's new commute was only fifteen minutes, he would be able to go fishing after work sometimes. [3] I was sad to say goodbye to my friends when we finally did move. [4] However, I had to admit that my father looked happier than he had in years. [5] Before the move, he used to complain about crazy drivers while eating reheated

10. F. NO CHANGE  
 G. more happier then  
 H. happier then  
 J. the happiest than

leftovers. [6] After the move, we had dinner and, talked about

11. A. NO CHANGE  
 B. dinner and talked,  
 C. dinner, and talked  
 D. dinner and talked

the weekend calmly as a family. 12

12. For the sake of the logic and coherence of this paragraph, Sentence 5 should be placed:  
 F. where it is now.  
 G. after Sentence 1.  
 H. after Sentence 2.  
 J. after Sentence 3.

**GO ON TO THE NEXT PAGE.**



As I got older, when we visited family and friends in Southern California, I could see the difference from the traffic at <sup>13</sup> home in Redding. There weren't any huge rats on the highway,

but as I sat in the car watching the endless lines of cars, I got a <sup>14</sup> glimpse of what my parents had meant. Redding might have been unpleasantly empty of familiar associations for me but that same emptiness was more pleasant for my parents, because it included empty roads, empty skies, and empty days to fill as they pleased.

13. A. NO CHANGE  
 B. California;  
 C. California,  
 D. California and
14. F. NO CHANGE  
 G. unending and interminable lines  
 H. endlessly, continuing forever, lines  
 J. lines, going on into eternity without end

Question 15 asks about the preceding passage as a whole.

15. Suppose the writer's goal had been to write a short essay telling the reader why, in her opinion, her family moved to Redding. Would this essay successfully fulfill that goal?
- A. Yes, because it describes her father's reasons for wanting to move, as the author understands them.  
 B. Yes, because it demonstrates that children sometimes have misconceptions about the reasons for a move.  
 C. No, because it fails to explain why the author was frightened by the prospect of the move.  
 D. No, because it focuses more heavily on the feelings of a party other than the author.

## PASSAGE II

### The Latino Murals of Los Angeles

The Mexican-American artist Judith Baca credits her family for her artistic inspiration. She was raised by her mother and grandmother, themselves in a vibrant Latino community in East <sup>16</sup> Los Angeles. Her art is thus a tribute to her family's past as well

as to her cultural heritage, which she believes her art embodies <sup>17</sup> the spirit of Los Angeles.

Baca studied art both in Los Angeles and Cuernavaca, Mexico. Her chosen field of art, the mural, has long been a part <sup>18</sup> of Mexican artistic culture and has experienced a popular

16. F. NO CHANGE  
 G. grandmother, themselves,  
 H. grandmother related to her  
 J. grandmother
17. A. NO CHANGE  
 B. heritage;  
 C. heritage,  
 D. heritage, but
18. F. NO CHANGE  
 G. art, the mural—  
 H. art the mural—  
 J. art the mural,

**GO ON TO THE NEXT PAGE.**

revival in Los Angeles in recent years. She has gained fame for her colorful murals depicting episodes from Latino history, many

of which can be found in the Los Angeles area. 20

Moreover, the recent popularity of the mural as a form of art is often linked to the prevalence of graffiti in urban areas.

Some of the earliest examples of modern murals, such as

Willie Herrón's *The Wall That Cracked Open*, was treated as graffiti, rather than art. Many muralists remain anonymous, and their works tend to be in public places.

Some murals political messages also made people uneasy about this art form in the early days of its resurgence.

Today, however, city officials often hire known muralists such as Baca to create masterpieces on government property. Because of their size, murals often require the assistance of other artists and, as evidence, sometimes become community efforts. Murals are also

a way for people to connect their cultural past with their present reality, by using traditional figures to tell modern stories.

It is this community involvement that has helped sway the minds of officials, as well as the realization that many murals convey positive messages. Some depict scenes

19. The underlined phrase could be placed in all the following locations EXCEPT:
- where it is now.
  - after the word *revival*.
  - after the word *popular*.
  - before the word *experienced*.
20. If the writer were to delete the preceding sentence, the essay would primarily lose:
- an artistic evaluation of Baca's techniques compared to traditional techniques.
  - an explanation of the historical circumstances that led to the development of murals as an art form.
  - an analysis of Baca's place in the rebirth of murals with themes from Latino history.
  - a piece of information regarding Baca's success and one region in which her work is popular.
21. A. NO CHANGE  
B. However, the  
C. The  
D. Therefore, the
22. F. NO CHANGE  
G. was mistakenly treated  
H. were treated  
J. was treated, by mistake,
23. A. NO CHANGE  
B. murals political messages,  
C. mural's political messages  
D. murals' political messages
24. F. NO CHANGE  
G. stated  
H. a result  
J. imagined
25. Given that all the choices are true, which one provides the most relevant information at this point in the essay?
- NO CHANGE
  - more accessible to members of the public than most art is, because they are located in the heart of the community.
  - often funded by government agencies that want to cover up abandoned factories and warehouses.
  - particularly effective for telling allegorical stories, in part because their large size gives artists so much room.

**GO ON TO THE NEXT PAGE.**

of multicultural harmony, they are inspired by the neighborhoods in which they are situated. Others show

scenes of past successes by members of the community. Still others strive to depict the historic achievements of the generations past.

By creating beautiful murals in her neighborhood, Baca is working to create a sense of community pride. The bright

faces of the people, she paints signal the bright possibilities

available to the viewer. They're successes, Baca suggests, can be yours.

26. F. NO CHANGE  
G. harmony, it was prompted  
H. harmony, that was inspired  
J. harmony, inspired
27. A. NO CHANGE  
B. by members of the community of past successes  
C. of past successes of the community by members  
D. of the community by members of past successes
28. F. NO CHANGE  
G. a sense of community pride is being created by Baca.  
H. the community is developing a sense of pride.  
J. a sense of community pride, which Baca is working to create.
29. A. NO CHANGE  
B. people she paints:  
C. people; she paints  
D. people she paints
30. F. NO CHANGE  
G. Its  
H. Their  
J. It's

### PASSAGE III

#### The Birth of the Video Game

The last decade had saw increasingly sophisticated video gaming consoles that allow players to compete at great distances, control characters through body movements, and much more. The possibilities of video gaming, taken for granted today, were mind-blowing in 1972 when Nolan Bushnell and Ted Dabney introduced the public to their new creation: *Pong*.

There had been other video games before *Pong*, of course. The necessary technology had been developed as early as 1952, and *Pong* were preceded by several other games, such as *Tennis for Two*, *Spacewar!*, and *Computer Science*.

31. A. NO CHANGE  
B. has seen  
C. has saw  
D. would of seen
32. F. NO CHANGE  
G. 1972, where  
H. 1972, in which  
J. 1972, that
33. A. NO CHANGE  
B. precede  
C. was preceding  
D. was preceded

**GO ON TO THE NEXT PAGE.**



However, it was not until *Pong*, with its simple interface and addictive nature, that the concept of home video gaming systems really took off. <sup>34</sup>

[1] Looking back on *Pong* today, it seems ridiculously old-fashioned, so it's easy to contrast it with modern games. [2] It's not that *Pong* was the most advanced game of the

era: several earlier games, in fact; were actually more technologically advanced. [3] *Pong*'s strength was its

combination of novelty and accessibility. [4] The other games, sophisticated as they were, simply proved too difficult for

the average consumer or person considering making a purchase.

[5] However, it was groundbreaking in its day, in it's own way.

34. The writer is considering deleting the preceding sentence from the essay. The sentence should NOT be deleted because it:
- F. serves as a transition from the more general discussion about *Pong* to the more specific description of what made *Pong* successful.
  - G. describes the technical skill required to play *Pong*, which is important to understanding the essay.
  - H. demonstrates which elements of *Pong* led to its ultimate ascendance over other, more technologically sophisticated games.
  - J. shows that those who claim that *Pong* was the first modern video game are basing their claim on insufficient information.
35. Given that all the choices are true, which one would best complete the sentence so that it most clearly explains the writer's reasons for calling *Pong* "old-fashioned"?
- A. NO CHANGE
  - B. with its basic graphics, simplistic game play, and repetition.
  - C. and some people like for things to stay that way.
  - D. because of the lack of technological development and complex game-play.
36. F. NO CHANGE  
G. games in fact,  
H. games, in fact,  
J. games, in fact
37. Which of the following alternatives to the underlined word would be LEAST acceptable?
- A. uniqueness
  - B. complexity
  - C. innovation
  - D. freshness
38. F. NO CHANGE  
G. consumer or individual possibly purchasing it.  
H. consumer or someone making a purchase, possibly.  
J. consumer.
39. A. NO CHANGE  
B. they're  
C. their  
D. its
40. For the sake of the logic and coherence of this paragraph, Sentence 5 should be placed:
- F. where it is now.
  - G. after Sentence 1.
  - H. after Sentence 2.
  - J. after Sentence 3.

**GO ON TO THE NEXT PAGE.**

The history of the video game becomes more understandable when it is remembered that the creators of early games were primarily engineers and mathematicians, developing these games for their own amusement, they paid little attention to popular marketing. These pioneering developers saw the games they created as “doodling,” more or less. Even when they introduced their products to the public, they usually did so as part of a showpiece, on a temporary basis.

So just think of how far video game technology has come, and don't forget that the technology continues to advance every day. In *Pong*, a player uses a single knob to send a “ball” back and forth across the screen, gaining points and trying to prevent the ball from slipping past the “paddle,” a bar at the bottom of the screen. Compared to high complex games like *Super Mario Galaxy* and *Halo*, *Pong* may seem laughable.

But anyway, I still think *Pong* is fun to play sometimes.

41. A. NO CHANGE  
 B. mathematicians only developing  
 C. mathematicians. Developing  
 D. mathematicians, only developing
42. F. NO CHANGE  
 G. public, whom they met at special events,  
 H. public, who wouldn't normally see their products,  
 J. public, with whom they spoke at events,
43. A. NO CHANGE  
 B. high complexity  
 C. highly complexity  
 D. highly complex
44. Given that all the choices are true, which one would most effectively express the writer's attitude towards the future of the video game industry?  
 F. NO CHANGE.  
 G. The men who created *Pong* are truly to be thanked for introducing the world to one of its most entertaining hobbies.  
 H. At its core, *Pong* represents the ultimate goal of all video games: just having a good time.  
 J. Still, it opened the door to all of the advances that have come since, and that will no doubt continue until the games of today seem just as ridiculous as *Pong*.

Question 45 asks about the preceding passage as a whole.

45. Suppose the writer's goal had been to write an essay demonstrating the impact a single invention can have on the development of an industry. Would this essay fulfill that goal?  
 A. No, because the essay focuses too heavily on the other games that preceded *Pong* rather than its actual impact.  
 B. No, because the essay concludes that *Pong* was ultimately not as influential as some assert.  
 C. Yes, because the essay explains how *Pong* was able to gain widespread acceptance for video games.  
 D. Yes, because the essay demonstrates that *Pong* was the first video game released to the public.

**GO ON TO THE NEXT PAGE.**

## PASSAGE IV

**The Life of a Hero**

During a weekend visit a while back, I decided to show my nephew, Paul, my old comic books. The pristine copies of <sup>46</sup>*Superman*, *Spider-Man*, and my favorite, *Green Lantern*, were all stored neatly in a box. I thought it would be fun to introduce him to my favorite handful of characters. I knew Superman and Spider-Man were still popular, but I figured the Green Lantern of my youth had probably went the way of other long-forgotten <sup>47</sup>heroes.

John Stewart, the first African-American to serve as the Green Lantern was one of the first African- <sup>48</sup>American superheroes to become widely popular. A

former Marine and a practiced and fearsome warrior. With <sup>49</sup>

his ring, he was almost unstoppable. He was a fighter, <sup>50</sup>leading, and, on top of everything else, acting cool. Stewart

seemed to embody everything I could have wanted for my <sup>51</sup>future: the respect of others, the power to control himself,

and he was known for having a great sense of style. <sup>52</sup>

46. Which choice provides the most specific information?

- F. NO CHANGE
- G. a few years ago
- H. last summer
- J. some time ago

47. A. NO CHANGE

- B. gone
- C. left
- D. went out

48. F. NO CHANGE

- G. Lantern, was one,
- H. Lantern, was one
- J. Lantern was one,

49. A. NO CHANGE

- B. Marine, he practiced
- C. Marine, he was a practiced
- D. Marine, practicing

50. F. NO CHANGE

- G. was good at fighting,
- H. had an ability to fight,
- J. could fight,

51. A. NO CHANGE

- B. could of wanted
- C. could of been wanting
- D. DELETE the underlined portion

52. F. NO CHANGE

- G. he dressed with great personal style.
- H. the best sense of style ever.
- J. his sense of personal style was really great.

**GO ON TO THE NEXT PAGE.**

Growing up in the 1970s, I idolized Stewart. <sup>53</sup> I devoured the comics featuring Stewart, not just because he was a true superhero but because of his back-story. Unlike Superman, Stewart seemed like a hero I could understand.

His life had its ups and its downs; his problems were real life <sup>54</sup> problems that I could relate to. He got in trouble sometimes and <sup>54</sup> fought with his friends and family. He came from a bad neighborhood and hadn't always been on the road to superhero status.

For a little while in the early 1990s, there was a series that focused solely on Stewart as the Green Lantern, but after <sup>55</sup> it ended, Stewart was replaced and seemed likely to be

forgotten. Much to my surprise, <sup>56</sup> however, Paul knew exactly who Stewart was. He was just as big a fan as I had been, but

for different reasons. For me, <sup>57</sup> Stewart's rocky life story was central to his appeal. For Paul, however, Stewart's past didn't matter as much as did his actions; Paul admired Stewart because <sup>58</sup> he was such a strong role model.

When I was young, Stewart was a role model that I could identify with. I assumed Paul would either have his own role models or would share my feelings about my role models.

53. At this point, the writer is considering adding the following true statement:

Each Green Lantern was chosen by a group called The Guardians, whose members took into consideration a number of personal qualities, including physical strength, moral fiber, and a strong sense of duty to all living beings.

Should the writer make this addition here?

- A. Yes, because it provides important background information that helps the reader understand the essay.  
 B. Yes, because it contributes to the writer's discussion of Stewart's positive attributes.  
 C. No, because it undermines the author's claim that Stewart was a more realistic role model.  
 D. No, because it provides information that is irrelevant to the main point of the paragraph.
54. Given that all of the choices are true, which one best explains the author's belief that Stewart was a more understandable character and shows a more realistic image of Stewart?
- E. NO CHANGE  
 G. Stewart was a more sympathetic character and I had an easier time imagining myself in his shoes.  
 H. The Green Lantern ring allowed Stewart to fly into space, create weapons out of thin air, and protect his friends.  
 J. Unlike Superman, Stewart couldn't fly without his ring because he didn't naturally have superpowers.
55. A. NO CHANGE  
 B. after;  
 C. after:  
 D. after,
56. Which of the following alternatives to the underlined portion would be LEAST acceptable?
- E. though,  
 G. furthermore,  
 H. on the contrary,  
 J. DELETE the underlined portion
57. A. NO CHANGE  
 B. Stewarts rocky  
 C. Stewarts' rocky,  
 D. Stewart's rocky
58. Which choice most effectively supports the point being made in the first part of this sentence?
- E. NO CHANGE  
 G. of what he did, not who he was.  
 H. of what he represented.  
 J. he was able to overcome his past.

**GO ON TO THE NEXT PAGE.**

Instead, he shared my role models but not my reasons. To him, Stewart was simply a superhero, just like Superman. He admired them both without worrying about that. In Paul's worldview, all

59. A. NO CHANGE  
 B. their back-stories.  
 C. all that.  
 D. those.

superheroes are simply superheroes they're heroes, regardless of their pasts, not because of them.

60. F. NO CHANGE  
 G. superheroes; they're  
 H. superheroes, they're  
 J. superheroes being

## PASSAGE V

### Into the Trenches

It has often been suggested that, contrary to the worn-out time saying, the ocean, rather than space, is the true

61. A. NO CHANGE  
 B. timeworn  
 C. timed out  
 D. out of time

final frontier. There is the immense pressure that poses a serious danger to unknown geography that can injure people and vessel alike, various factors make sending human explorers very risky.

62. F. NO CHANGE  
 G. From  
 H. Just like  
 J. Between

Deep-sea expeditions also tend to incur prohibitive costs, with the cost increasing as the expedition ventures into deeper regions. The deepest section of the ocean is the *Marianas Trench*. <sup>64</sup> Due primarily to its depth and the potential for danger, the *Marianas Trench* remains largely unexplored to this day.

63. Given that all the choices are true, which one is the most relevant to the statement that follows in this sentence?
- A. NO CHANGE  
 B. are known for being rather difficult,  
 C. are dangerous to diver and sea-life alike,  
 D. often cause damage to human life and to equipment,
64. The writer is considering adding the following true information to the end of the preceding sentence (placing a comma after the word *Trench*):
- which begins at 20,000 feet and has points where the depth approaches seven miles and pressure reaching eight tons per square inch.
- Should the writer make this addition?
- F. Yes, because it provides specific information about the *Marianas Trench* that explains why the author included this sentence.  
 G. Yes, because it demonstrates how valuable human-led explorations of the depths of the ocean are likely to be.  
 H. No, because it detracts from the writer's discussion of the potential dangers of deep-sea exploration.  
 J. No, because it weakens the writer's point about the correlation between increasing depth and increasing cost.

**GO ON TO THE NEXT PAGE.**



The shallow portions of the oceans also hold many fascinating species of plants and animals. The environment, hostile though it may be to man, is hospitable to others,

allowing for the development of creatures not found anywhere else on the planet. The first and last exploration of the *Marianas*

*Trench*'s floor took place in 1960. Therefore, the cost of sending people back has been seen as too great, the danger as too serious.

The goal, then, has been to find a way to learn about this frontier without risking the lives of scientist-explorers. One way that scientists had discovered new information is through the use

of sonar. As sonar—which is far less expensive than a human-led diving expedition is—capabilities have improved, scientists have been able to get more accurate maps of the ocean's floor based on sound-imaging.

Another method of exploration that has become more common in recent years, as technology has advanced revolves around the use of unmanned submersibles. These include devices

as simple for cameras and as advanced as underwater robots able to perform a wide-range of functions. The latter have become increasingly common in recent years as they have become ever more advanced.

The question faced today is why these underwater robots will be sufficient, eliminating the need to send humans back

65. Given that all the choices are true, which one best leads from the preceding paragraph to the subject of this paragraph?
- A. NO CHANGE  
 B. One danger of deep-sea diving is a medical condition caused by an abrupt change in outside pressure.  
 C. Some argue that the bottom of the ocean isn't truly any more dangerous than the deep rainforest or highest mountain peaks.  
 D. Even knowing about all of the obstacles, however, some scientists feel the draw of the ocean's depths.
66. F. NO CHANGE  
 G. to which development has been allowed  
 H. which allows for the developing of  
 J. development has been allowed
67. A. NO CHANGE  
 B. Nevertheless,  
 C. In contrast,  
 D. Since then,
68. F. NO CHANGE  
 G. could of discovered  
 H. were discovering  
 J. have discovered
69. Given that all the choices are true, which one most effectively describes what sonar is?
- A. NO CHANGE  
 B. initially developed during World War I—  
 C. a sound-based method of determining surroundings—  
 D. not completely unlike the echolocation used by certain animals—
70. F. NO CHANGE  
 G. advanced,  
 H. advanced—  
 J. advanced:
71. A. NO CHANGE  
 B. as  
 C. than  
 D. DELETE the underlined portion
72. F. NO CHANGE  
 G. what  
 H. whether  
 J. DELETE the underlined portion

**GO ON TO THE NEXT PAGE.**



into the depths. Most of the robots used thus far have been  
73  
 “tethered,” or attached in some way to a larger device with  
 people aboard, the day when the robots can move independently  
 may not be far off. Given the extreme depths of some locations,  
 however, it seems likely that self-propelled robots will become  
 more useful and handy. If that is the case, one is forced to  
74  
 wonder: are more complex robots truly the key, or will humans

need to venture back into the ocean’s inky depths? 75

73. A. NO CHANGE  
 B. Most, if not all,  
 C. Although most  
 D. All or most

74. E. NO CHANGE  
 G. practically useful.  
 H. useful.  
 J. effectively useful.

75. The writer is considering ending the essay with the following sentence:

Perhaps one day humans will be able to create a robot able to simulate the emotional responses of a human, or even a robot with the ability to experience feelings.

Should the writer add this sentence here?

- A. Yes, because it expands the essay to encompass the ethical concerns raised by the development of artificial intelligence.  
 B. Yes, because it explains one reason for continued reliance on robots in deep-sea explorations.  
 C. No, because it fails to consider the usefulness of robots in present and future deep-sea exploration, as well as whether their use is cost-effective.  
 D. No, because it distracts from the essay’s central topic of deep-sea exploration and the issues preventing humans from leading expeditions.

**END OF TEST 1**

**STOP! DO NOT TURN THE PAGE UNTIL TOLD TO DO SO.**



## MATHEMATICS TEST

60 Minutes—60 Questions

**DIRECTIONS:** Solve each problem, choose the correct answer, and then darken the corresponding oval on your answer sheet.

Do not linger over problems that take too much time. Solve as many as you can; then return to the others in the time you have left for this test.

You are permitted to use a calculator on this test. You may use your calculator for any problems you choose,

but some of the problems may best be done without using a calculator.

Note: Unless otherwise stated, all of the following should be assumed:

1. Illustrative figures are NOT necessarily drawn to scale.
2. Geometric figures lie in a plane.
3. The word *line* indicates a straight line.
4. The word *average* indicates arithmetic mean.

## DO YOUR FIGURING HERE.

1. If  $\frac{5y-1}{3} = -6$ , then which of the following must be true?

A.  $y = -18$

B.  $y = -\frac{19}{5}$

C.  $y = -\frac{17}{5}$

D.  $y = -1$

E.  $y = \frac{17}{5}$

2. The expression  $\frac{12z^{10}}{4z^2}$  is equivalent to:

F.  $3z^5$

G.  $8z^5$

H.  $3z^8$

J.  $8z^8$

K.  $8z^{12}$

3. If  $f(x) = \frac{x^2-18}{x+2}$ , then  $f(12) = ?$

A.  $-4$

B.  $3$

C.  $9$

D.  $12$

E.  $126$

GO ON TO THE NEXT PAGE.



4. In one month, Rebecca, an entertainment journalist, recorded how many movies she watched and how many articles she wrote. She plotted this data in the graphs below: Graph 1 shows the relationship between the time elapsed and the number of movies watched; Graph 2 shows the relationship between the number of movies watched and the number of articles written. According to this data, how many articles did she write in the first 3 weeks of this month?

**DO YOUR FIGURING HERE.**

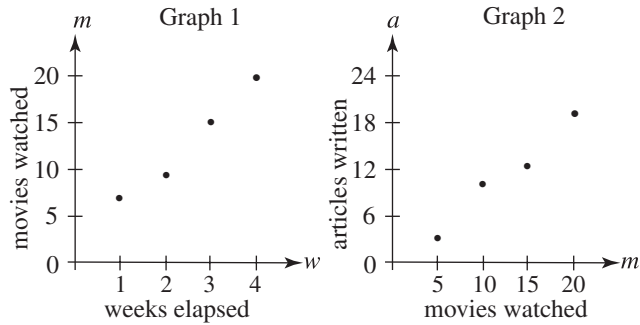

- F. 3  
 G. 5  
 H. 8  
 J. 12  
 K. 15
5. What is the value of  $117 - 54 + 6$ , rounded to the nearest ten?
- A. 40  
 B. 50  
 C. 60  
 D. 70  
 E. 80
6. A restaurant has 4 napkins at each table, plus 20 extra napkins held in reserve. If the restaurant has a total of 100 napkins, how many tables are in the restaurant?
- F. 15  
 G. 20  
 H. 25  
 J. 30  
 K. 35
7. If  $4(w - 2) - w = 46$ , then  $w = ?$
- A. 8  
 B. 10  
 C. 16  
 D. 18  
 E. 20

**GO ON TO THE NEXT PAGE.**



## DO YOUR FIGURING HERE.

8. Six points ( $U, V, W, X, Y, Z$ ) appear on a number line in that order, as shown in the figure below. Which of the following rays does NOT contain  $\overline{WX}$ ?

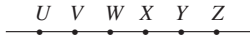

- F.  $\overrightarrow{UY}$   
 G.  $\overrightarrow{VZ}$   
 H.  $\overrightarrow{YV}$   
 J.  $\overrightarrow{YZ}$   
 K.  $\overrightarrow{ZV}$
9. If  $ab = 32$ ,  $bc = 40$ , and  $c = 5$ , then which of the following is the value of  $a$ ?
- A. 4  
 B. 6  
 C. 8  
 D. 10  
 E. 12
10. Yunyun swam 4 laps, and her coach recorded her time for each as 43.4 seconds, 44.1 seconds, 42.9 seconds, and 45.4 seconds, respectively, for a total of 175.8 seconds. If Yunyun must swim her 5th lap in  $x$  seconds in order to make her average time for all 5 laps 43 seconds, then which of the following equations could be solved for the correct value of  $x$ ?
- F.  $\frac{175.8 + x}{5} = \frac{43}{60}$   
 G.  $\frac{175.8 + x}{5} = 43$   
 H.  $\frac{175.8 + x}{4} = 43$   
 J.  $\frac{175.8}{5} + x = 43$   
 K.  $\frac{175.8}{4} + x = 43$
11. For how many integers from 123 to 132 is the tens digit greater than the ones digit?
- A. 2  
 B. 3  
 C. 4  
 D. 9  
 E. 10

GO ON TO THE NEXT PAGE.



12. The number of points Julie scores in a basketball game is proportional to the amount of time she practiced that week. Last week, Julie scored 20 points after practicing for 12 hours. How many hours should Julie practice this week if she wants to score 35 points?

F. 7  
 G. 14  
 H. 16  
 J. 20  
 K. 21

**DO YOUR FIGURING HERE.**

13. Rectangle  $ABCD$  is graphed in the  $(x,y)$  coordinate plane below. What fraction of rectangle  $ABCD$  lies in Quadrant IV?

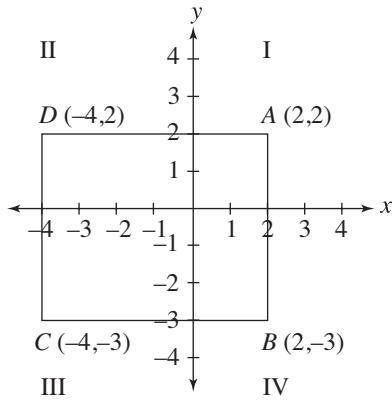

A.  $\frac{2}{15}$   
 B.  $\frac{1}{5}$   
 C.  $\frac{4}{15}$   
 D.  $\frac{1}{3}$   
 E.  $\frac{2}{5}$

**GO ON TO THE NEXT PAGE.**



14. Which of the following is equivalent to the expression

$$\frac{2(z+3)-9}{5+4(z+3)}?$$

F.  $-\frac{9}{5}$

G.  $-\frac{9}{10}$

H.  $-\frac{7}{9}$

J.  $\frac{-7z-21}{9z+15}$

K.  $\frac{2z-3}{4z+17}$

**DO YOUR FIGURING HERE.**

15. A circle with the equation  $x^2 + y^2 = 49$  is graphed in the standard  $(x,y)$  coordinate plane. At which 2 points does this circle intersect the  $x$ -axis?

A.  $(-1, 0)$  and  $(1, 0)$

B.  $(-7, 0)$  and  $(7, 0)$

C.  $(-14, 0)$  and  $(14, 0)$

D.  $(-21, 0)$  and  $(21, 0)$

E.  $(-49, 0)$  and  $(49, 0)$

16. 
$$\left[ \begin{array}{cc|c} 4 & -3 & 13 \\ 5 & 2 & 45 \end{array} \right]$$

The augmented matrix above could represent which of the following systems of linear equations?

F.  $4m + 3n = 13$   
 $5m - 2n = 45$

G.  $5m - 3n = 13$   
 $4m + 2n = 45$

H.  $4m - 3n = 13$   
 $5m + 2n = 45$

J.  $4m + 5n = 13$   
 $-3m + 2n = 45$

K.  $4m + 3n = 13$   
 $-5m - 2n = 45$

**GO ON TO THE NEXT PAGE.**



17. In 1905, the distance between the edge of a lake and Marker X was 75 meters. In 2005, the distance between the edge of this lake and Marker X was 825 meters. If the edge of this lake withdrew from Marker X at a linear rate, then what was the distance, in meters, between the edge of the lake and Marker X in 1985 ?

A. 675  
 B. 682.5  
 C. 690  
 D. 705  
 E. 750

**DO YOUR FIGURING HERE.**

18. For a decorating project, Beatrice found the area and perimeter of a drawing she made of a beach scene. She found that the area of her rectangular drawing was 144 square inches and that the perimeter was 80 inches. When she arrived at the craft store to purchase a frame for her drawing, she discovered that she had forgotten to write down the dimensions of her drawing. What are the dimensions of Beatrice's drawing, in inches?

F. 4 by 36  
 G. 6 by 24  
 H. 8 by 18  
 J. 9 by 16  
 K. 12 by 12

19. Which of the following is equivalent to  $\frac{6.0 \times 10^5}{1.5 \times 10^7}$  ?

A.  $4.0 \times 10^2$   
 B.  $4.0 \times 10^{-2}$   
 C.  $4.0 \times 10^{12}$   
 D.  $4.5 \times 10^{12}$   
 E.  $4.5 \times 10^{-2}$

20. All 7-digit phone numbers at a university start with the same 3-digit prefix. How many phone numbers can be generated for the university before a new prefix must be used?

F.  $10^7$   
 G.  $7^{10}$   
 H.  $4^9$   
 J.  $9^4$   
 K.  $10^4$

**GO ON TO THE NEXT PAGE.**





**DO YOUR FIGURING HERE.**

21. The cost to rent headphones at the listening library is \$3.50 for the first hour (or any fraction thereof), \$2.50 for the second hour (or any fraction thereof), and \$1.25 for each additional hour (or any fraction thereof) beyond the first two. If you rent headphones at 2:12 P.M. and are charged \$9.75 when you return them, then which of the following could be the time you return the headphones?

(Note: Assume that this listening library does not charge additional taxes or fees.)

- A. 5:30 P.M.
  - B. 6:30 P.M.
  - C. 7:30 P.M.
  - D. 8:00 P.M.
  - E. 8:30 P.M.
22. The degree measures of the 4 angles of quadrilateral  $LMNO$ , not shown, form a geometric sequence with a common ratio of 2. What is the last term of the sequence?
- F.  $24^\circ$
  - G.  $96^\circ$
  - H.  $160^\circ$
  - J.  $192^\circ$
  - K.  $216^\circ$

23. Ray  $\overrightarrow{FH}$  bisects  $\angle EFG$  and the measure of  $\angle EFH$  is  $(2n + 34)$ . If the measure of  $\angle EFG$  is  $140^\circ$ , what is the value of  $n$ ?

- A.  $17^\circ$
- B.  $18^\circ$
- C.  $36^\circ$
- D.  $52^\circ$
- E.  $70^\circ$

**GO ON TO THE NEXT PAGE.**



**DO YOUR FIGURING HERE.**

24. If  $6x + 10y = 14$  and  $3x + 4y = 2$ , then what is the value of  $5x + 7y$ ?

F. 5  
G. 2  
H. -5  
J. -7  
K. -12

25. Which of the following correctly solves the equation  $\frac{a-b}{2} = 6$  for any  $b$ ?

A.  $b = 12a$   
B.  $b = 12 - a$   
C.  $b = 3 - a$   
D.  $b = a - 3$   
E.  $b = a - 12$

26. The product of which of the following results in a negative odd number?

F. A positive even number and a negative even number  
G. Two negative odd numbers  
H. A positive even number and a negative odd number  
J. A negative even number and a negative odd number  
K. A positive odd number and a negative odd number

27. A bag contains 11 purple marbles, 11 yellow marbles, 11 red marbles, and 11 black marbles. John begins removing marbles at random from the bag, and the first 4 marbles removed are all purple. What is the probability that the fifth marble removed will also be purple?

A.  $\frac{7}{44}$   
B.  $\frac{7}{40}$   
C.  $\frac{1}{4}$   
D.  $\frac{5}{11}$   
E.  $\frac{7}{11}$

**GO ON TO THE NEXT PAGE.**



28. A student in Miss Ruane's class must repeat a test if that student earns less than 70% of the points available on that test. There were 30 points available on the first test of this semester. If Oliver scored  $p$  points on this test and therefore must repeat it, then which of the following must be true?

- F.  $p < 20$
- G.  $p > 20$
- H.  $p < 21$
- J.  $p = 21$
- K.  $p > 21$

**DO YOUR FIGURING HERE.**

29. A work crew paints a broken yellow line down the middle of a straight road  $16\frac{1}{9}$  miles long over the course of 3 days. On Day 1, the crew records  $5\frac{8}{27}$  miles of road painted. On Day 2, the crew forgets to measure how much road was painted, but on Day 3, the crew records  $3\frac{2}{3}$  miles painted to finish the job. According to the measurements available, how many miles of road did the crew paint on Day 2?

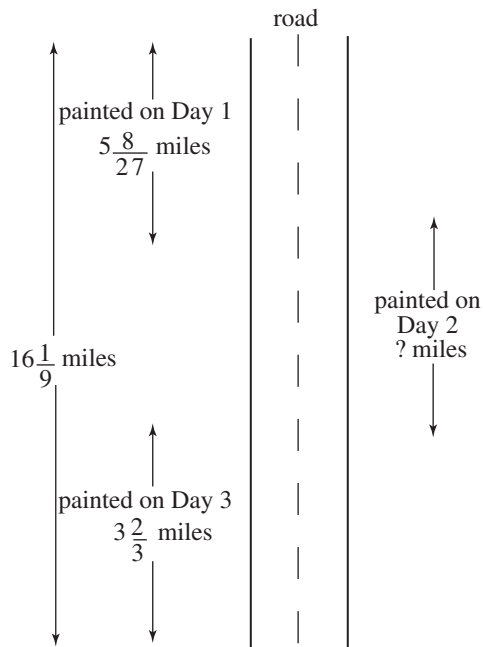

- A.  $7\frac{7}{27}$
- B.  $7\frac{4}{27}$
- C. 7
- D.  $6\frac{7}{27}$
- E.  $6\frac{4}{27}$

**GO ON TO THE NEXT PAGE.**



30. The owners of the Movie Palace use the *Illuminator 100* light bulb in their projectors, but are now considering switching to the *Illuminator 100 Plus*, a more powerful light bulb that projects movies onto larger screens farther away. The *Illuminator 100 Plus* projects movies onto screens 108 feet wide and 180 feet from the projector, while the *Illuminator 100* projects movies onto screens only 81 feet wide, as shown in the figure below. How much farther from the projector, in feet, is the screen for the *Illuminator 100 Plus* than the screen for the *Illuminator 100*?

DO YOUR FIGURING HERE.

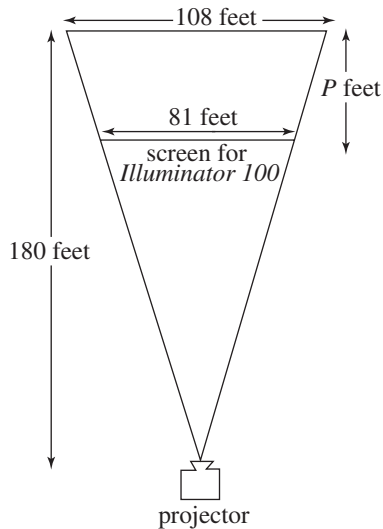

- F. 27  
 G. 40  
 H. 45  
 J. 50  
 K. 55
31. What is the distance, in coordinate units, between points  $J(-5,4)$  and  $K(6,-2)$  in the standard  $(x,y)$  coordinate plane?
- A.  $\sqrt{15}$   
 B.  $\sqrt{17}$   
 C.  $\sqrt{157}$   
 D. 10  
 E. 17

GO ON TO THE NEXT PAGE.



DO YOUR FIGURING HERE.

32. Cynthia decorates the ceiling of her bedroom with stars that glow in the dark. She puts 1 star on the ceiling on the 1st day of decorating, 2 stars on the ceiling on the 2nd day of decorating, 3 stars on the ceiling on the 3rd day, and so on. If she puts stars on the ceiling in this pattern for 30 days (so she puts 30 stars on the ceiling on the 30th day), then what will be the total number of stars on the ceiling at the end of the 30 days?

- F. 155
- G. 435
- H. 450
- J. 465
- K. 480

33. In  $\triangle PQR$ , side  $\overline{PQ}$  is 12 inches long and side  $\overline{QR}$  is 41 inches long. Which of the following CANNOT be the length, in inches, of side  $\overline{PR}$ ?

- A. 17
- B. 30
- C. 38
- D. 44
- E. 52

34. Which of the following is equivalent to the expression

$$\frac{5d^2 - 2}{20d} ?$$

- F.  $\frac{3}{20}$
- G.  $\frac{1}{5d^2}$
- H.  $d$
- J.  $\frac{d}{4} - \frac{1}{10d}$
- K.  $\frac{d^2 - 1}{10d}$

GO ON TO THE NEXT PAGE.



Use the following information to answer questions 35–37.

DO YOUR FIGURING HERE.

Merav's school has an Olympic-size pool that is 50 meters long, 25 meters wide, and 2 meters deep. The pool is surrounded by special non-slip tiles, as shown in the figure below.

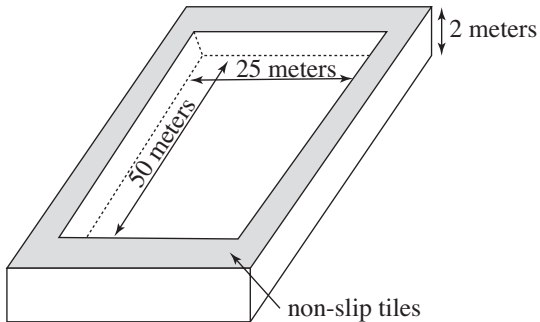

35. Merav's school laid non-slip tiles on the floor around its pool to reduce injuries among its athletes. These non-slip tiles extend 5 meters beyond the pool on all sides. What is the area, in square meters, of the floor space that has the non-slip tiles?
- A. 800  
 B. 850  
 C. 900  
 D. 950  
 E. 1,000
36. For the synchronized swimming team, each swimmer needs an area within the pool to perform her routine without colliding with a teammate. Each area is 5 meters wide and 5 meters long. What is the maximum number of synchronized swimmers in the pool who can perform the routine without any collisions?
- F. 75  
 G. 50  
 H. 25  
 J. 15  
 K. 10
37. Merav pays \$4.00 for a ticket to her school's first swim meet to watch her classmates compete. While there, Merav buys a slice of pizza and a soda. She pays \$3.75 for the pizza and \$1.75 for the soda, plus 10% sales tax for both of these items. What is the total amount Merav pays for her ticket, pizza, and soda?
- A. \$ 3.75  
 B. \$ 9.50  
 C. \$10.05  
 D. \$10.45  
 E. \$10.75

GO ON TO THE NEXT PAGE.



DO YOUR FIGURING HERE.

38. Points  $G$  and  $H$  lie on circle  $F$  as shown below. If the measure of  $\angle FGH$  is  $40^\circ$ , then what is the measure of central angle  $\angle GFH$ ?

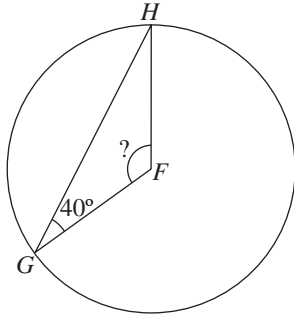

- F.  $60^\circ$   
 G.  $80^\circ$   
 H.  $100^\circ$   
 J.  $120^\circ$   
 K. Cannot be determined from the information given
39. The pie chart below shows the operating expenses of Stephanie's office for the month of July, during which time the expenses totaled \$10,000.

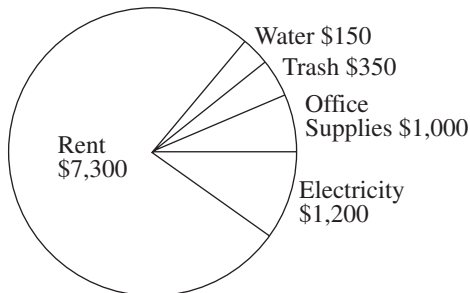

Stephanie tries to reduce her operating expenses for August by making her office more energy efficient and asking her landlord to lower her rent. She hopes to reduce her electricity expenses by \$700 and her rent by \$1,300. If she is successful in both of these goals and the rest of her expenses are unchanged, then what percent of her August expenses will be for office supplies?

- A. 5.0%  
 B. 7.5%  
 C. 10.0%  
 D. 12.5%  
 E. 15.0%
40. Assuming  $q$  is a positive integer, then the difference between  $14q$  and  $5q$  is always divisible by:
- F. 5  
 G. 9  
 H. 14  
 J. 19  
 K. 70

GO ON TO THE NEXT PAGE.



41. Ron earns \$1,800 for a 6-week assignment. While working a 6-week assignment, Ron works a minimum of 20 hours each week. Ron's hourly rate of pay, therefore, depends upon how many hours he works. If  $r$  is Ron's average hourly pay, in dollars, for a 6-week assignment, then which of the following best describes  $r$ ?
- A.  $r \leq \$15.00$   
 B.  $r \geq \$15.00$   
 C.  $r \leq \$90.00$   
 D.  $r \geq \$90.00$   
 E.  $r \geq \$180.00$
42.  $P$  and  $Q$  both represent complex numbers. If  $P = 2 + i$  and  $Q = 6 + 4i$ , what is the distance in coordinate units between  $P$  and  $Q$  in the complex plane?
- F.  $\sqrt{5}$   
 G.  $\sqrt{7}$   
 H. 4  
 J. 5  
 K. 7
43. Two wires connect the top of a flagpole to the ground, as shown below. Each wire has a length of 23 feet and attaches to the ground at a point 8 feet from the flagpole. Which of the following expressions gives the angle measure, in degrees, of the angle that the wire makes with the ground?

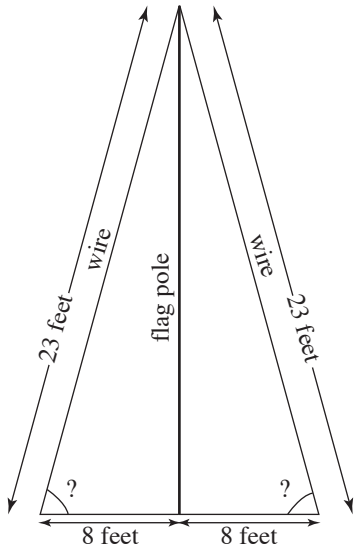

- A.  $\tan^{-1}\left(\frac{23}{8}\right)$   
 B.  $\tan^{-1}\left(\frac{8}{23}\right)$   
 C.  $\cos^{-1}\left(\frac{8}{23}\right)$   
 D.  $\cos^{-1}\left(\frac{23}{8}\right)$   
 E.  $\sin^{-1}\left(\frac{8}{23}\right)$

**DO YOUR FIGURING HERE.**

**GO ON TO THE NEXT PAGE.**





Use the following information to answer questions 44–46.

DO YOUR FIGURING HERE.

As shown in the figure below,  $\triangle XYZ$  is a right triangle with legs of length  $x$  units and  $y$  units, and hypotenuse of  $z$  units, such that  $0 < x < y$ . Quadrilaterals  $ABYX$ ,  $CDZY$ , and  $EFXZ$  are squares.

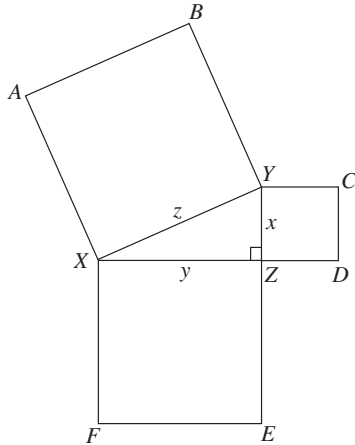

44. What is the perimeter, in units, of polygon  $CDZXY$  ?
- F.  $3x + y + z$   
 G.  $3x + 2y + z$   
 H.  $3x + 3y + 3z$   
 J.  $4x + y + z$   
 K.  $4x + 4y + 4z$
45. Given that  $0 < x < y$ , which of the following correctly lists the angles  $\angle BYC$ ,  $\angle AXF$ , and  $\angle EZD$  in order of their measures from least to greatest?
- A.  $\angle AXF, \angle EZD, \angle BYC$   
 B.  $\angle BYC, \angle EZD, \angle AXF$   
 C.  $\angle BYC, \angle AXF, \angle EZD$   
 D.  $\angle EZD, \angle AXF, \angle BYC$   
 E.  $\angle EZD, \angle BYC, \angle AXF$
46. If  $2x = z$ , then what is the value of  $\cos(\angle XYZ)$  ?
- F.  $\frac{1}{2}$   
 G.  $\frac{\sqrt{3}}{2}$   
 H.  $\frac{2\sqrt{3}}{3}$   
 J.  $\sqrt{3}$   
 K. 2

GO ON TO THE NEXT PAGE.



47. The sum of 4 consecutive even integers is  $t$ . What is the sum, in terms of  $t$ , of the 2 largest of these integers?

**DO YOUR FIGURING HERE.**

- A.  $\frac{t}{2} - 4$   
 B.  $\frac{t}{2}$   
 C.  $\frac{t}{2} + 4$   
 D.  $t + 2$   
 E.  $t + 4$

48. Figure 1 below shows the graph of  $y = x^2$  in the standard  $(x, y)$  coordinate plane. Which of the following is the equation for the graph in Figure 2 ?

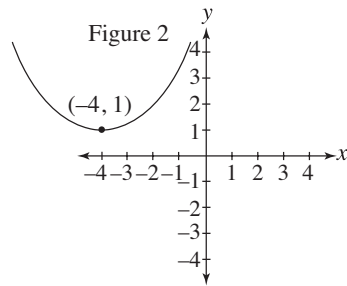
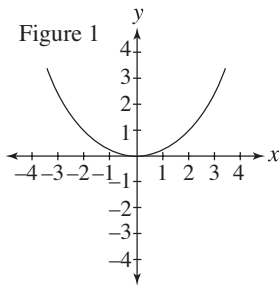

- F.  $y = (x - 4)^2 - 1$   
 G.  $y = (x - 4)^2 + 1$   
 H.  $y = (x + 1)^2 - 4$   
 J.  $y = (x + 4)^2 - 1$   
 K.  $y = (x + 4)^2 + 1$
49. In a piggy bank, there are pennies, nickels, dimes, and quarters that total \$5.29 in value. If there are 3 times as many dimes as there are pennies, 1 more dime than nickels, and 2 more quarters than dimes, then how many nickels are in the piggy bank?
- A. 11  
 B. 13  
 C. 17  
 D. 21  
 E. 23

**GO ON TO THE NEXT PAGE.**



50. The mean of 5 numbers is 87. The smallest of the 5 numbers is 75. What is the mean of the other 4 numbers?

F. 72  
 G. 87  
 H.  $88\frac{2}{5}$   
 J. 90  
 K.  $108\frac{3}{4}$

**DO YOUR FIGURING HERE.**

51. “If Jenny is home, then her car is in the driveway.” If the previous statement is true, then which of the following must also be true?

A. “If Jenny’s car is in the driveway, then she is home.”  
 B. “If Jenny is not home, then her car is in the driveway.”  
 C. “If Jenny is not home, then her car is not in the driveway.”  
 D. “If Jenny’s car is not in the driveway, then she is home.”  
 E. “If Jenny’s car is not in the driveway, then she is not home.”

52. If  $(y^{0.2})^{a^2-20} = y$  and  $y \neq 0$ , then what is the solution set of  $a$  ?

F. {1}  
 G.  $\{-\sqrt{10}, \sqrt{10}\}$   
 H. {5}  
 J.  $\{-5, 5\}$   
 K. {25}

53. If  $g(x) = \csc x \tan x$ , then which of the following trigonometric functions is equivalent to  $g(x)$  ?

(Note:  $\csc x = \frac{1}{\sin x}$ ,  $\sec x = \frac{1}{\cos x}$ , and  $\cot x = \frac{1}{\tan x}$  )

A.  $g(x) = \sin x$   
 B.  $g(x) = \cos x$   
 C.  $g(x) = \tan x$   
 D.  $g(x) = \csc x$   
 E.  $g(x) = \sec x$

**GO ON TO THE NEXT PAGE.**



54. Evan and Ron play a game of Rock, Paper, Scissors. Each round has three equally likely outcomes for Evan: win, lose, or tie. Evan earns 2 points for a win, but he earns nothing for a loss or a tie. Let the random variable  $N$  represent the total number of points he has after 5 rounds. What is the expected value of  $N$ ?

**DO YOUR FIGURING HERE.**

- F.  $\frac{5}{3}$
- G. 2
- H. 3
- J.  $\frac{10}{3}$
- K. 5
- 
55. If the volume of a sphere is  $288\pi$  cubic inches, then which of the following is the surface area, in square inches, of the same sphere?
- (Note: For a sphere with radius  $r$ , the volume is  $\frac{4}{3}\pi r^3$  and the surface area is  $4\pi r^2$ .)
- A.  $6\pi$
- B.  $8\pi$
- C.  $24\pi$
- D.  $36\pi$
- E.  $144\pi$

56. When  $x > 1$ ,  $3\log_x x^{-2} = ?$

- F. -6
- G.  $-\frac{2}{3}$
- H.  $\frac{2}{3}$
- J. 1
- K.  $\frac{3}{2}$

**GO ON TO THE NEXT PAGE.**



57. Jamie drew a triangle bounded by the lines  $y = -x$ ,  $x = -2$ , and  $y = 8$  and shaded the interior, as shown in the figure below. Then Jamie decided to reflect this triangle across the  $y$ -axis and shade the interior of the new triangle. Which of the following would describe the shaded region of Jamie's new triangle?

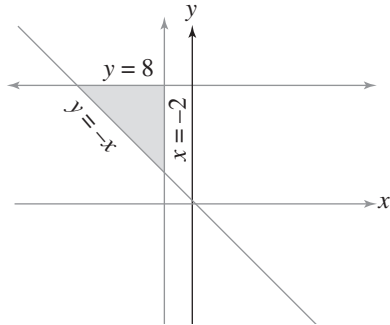

**DO YOUR FIGURING HERE.**

- A.  $x \geq 2$ ,  $y \leq 8$ ,  $y \leq x$   
 B.  $x \geq 2$ ,  $y \leq 8$ ,  $y \geq x$   
 C.  $x \geq 2$ ,  $y \leq -8$ ,  $y \leq x$   
 D.  $x \geq -2$ ,  $y \leq 8$ ,  $y \geq x$   
 E.  $x \leq -2$ ,  $y \leq -8$ ,  $y \leq x$
58. An angle with vertex at the origin and measure  $\theta$  is shown in the standard  $(x,y)$  coordinate plane below. If one side of the angle includes the positive  $x$ -axis and the other side passes through  $(-12,-5)$ , then what is the sine of  $\theta$ ?

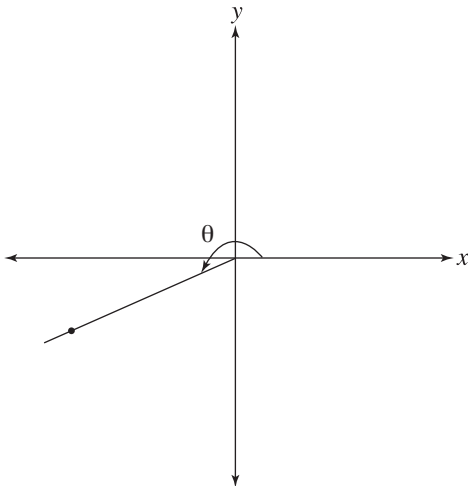

- F.  $-\frac{12}{5}$   
 G.  $-\frac{12}{13}$   
 H.  $-\frac{5}{13}$   
 J.  $\frac{5}{12}$   
 K.  $\frac{13}{12}$

**GO ON TO THE NEXT PAGE.**



59. Side  $\overline{AB}$  of parallelogram  $ABCD$  is shown in the figure below. If the coordinates of  $A$  are  $(7,6)$  and those of  $B$  are  $(5,1)$ , then  $\overline{CD}$  could lie on which of the following lines?

**DO YOUR FIGURING HERE.**

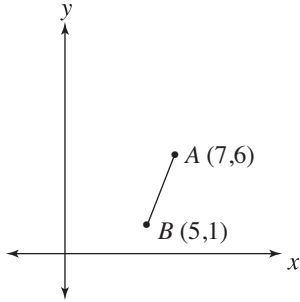

- A.  $y = \frac{5}{2}x + 9$
- B.  $y = x + 5$
- C.  $y = \frac{2}{5}x - 4$
- D.  $y = -\frac{2}{5}x + 4$
- E.  $y = -\frac{5}{2}x - 9$
60. If the function  $f(x,y)$  is defined as  $f(x,y) = (x - y)^2 + (x + y)^2$ , then, for all values of  $c$  and  $d$ ,  $f(c^2, d^2) = ?$
- F.  $4c^2d^2$
- G.  $2c^4 + 2d^4$
- H.  $2c^4 - 2d^4$
- J. 1
- K.  $-4c^2d^2$

**END OF TEST 2**  
**STOP! DO NOT TURN THE PAGE UNTIL TOLD TO DO SO.**  
**DO NOT RETURN TO A PREVIOUS TEST.**

## READING TEST

35 Minutes—40 Questions

**DIRECTIONS:** There are several passages in this test. Each passage is accompanied by several questions. After reading a passage, choose the best answer to each question and fill in the corresponding oval on your answer document. You may refer to the passages as often as necessary.

## Passage I

**PROSE FICTION:** This passage is adapted from the novel *Thick Skinned* by Grace McCloud, (©2005 by Grace McCloud). The setting is a forest in Oregon in 1935.

The dusk descends upon the earth like a series of linens slowly tucking a child into bed. The first sheet is just a soft lens that dampens the harsh glow of sunlight and reveals the untainted essence of the landscape. Colors seem richer, and subtle details are easier to perceive. The final layer of dusk comes on thick like a quilt, burrowing the world in darkness and allowing all the daytime creatures the glorious serenity in letting go.

As my father and I gathered twigs and leaves for our campfire, it was still the earliest stage of evening. The vibrant forms of daytime—flowers, trees, and radiant water—still flooded our eyes, but all the earth’s activity took on the falling action of a story that had passed its climax. The tension had been resolved; the expectations now clear; the progression calm. My mother was playing her role, setting up tents and laying out pillows and sleeping bags inside of them. Here, amid these familiar habits, the possibility of Dad losing his job at the plant, as so many of his friends had, began to evaporate with the disappearing sunlight.

The Wood River rolled by our campsite with a gentle gurgle. My father taught me to look at the river as he does: a metaphor for the human body. “The shape of it basically stays the same,” he said, “even though the underlying substance is always changing.”

My father was now attempting to start the fire with the first load of kindling. As he teased bits of leaves, sticks, and dry pine needles into a stack underneath the firewood, I went to look a second time for more of the same. Whenever you’re trying to ignite damp, untreated wood, you need to keep some tiny flame alive by finding a steady supply of easier things to burn.

I set off from the campsite in the opposite direction from the one I had gone before, just as a fisherman would sail downstream after catching the first load of fish. The snaps and pops of the burning tinder started to come with greater frequency. Then, without even turning to look towards the campsite, I knew things were under way.

Just like the grand finale of a 4th of July fireworks display, the sound of a blazing fire is a conversation of too many individual sparks to hear each of them speak.

“Honey, do you want me to start boiling some water?” my father yelled.

Even though it sounded like a question, it was really a request for my mother to hand him the pot. We always boil some water for the sake of the hot cocoa we would eventually sip by the fire, once all the work had been done to prepare the campsite for sleeping and the campfire for burning.

“Are you ready for your sandwich?” responded my mother, as she began pulling the water pot and other food supplies out of a paper bag.

I sometimes marveled at the well-grooved partnership my parents had carved out. It seemed so familiar to both of them. Often, I considered it a sign that the once-heaving seas of young love had quieted within them to something more like the standing water of a pond. However, right now the familiar habit of camping with my family was a welcome reprieve from the strange new presence at home: fear of the uncertain future. What sort of job would Dad get if he needed to find work? Would we have to move away from Eugene or back into the dusty basements of my aunts’ and uncles’ houses where I had spent my earliest years?

“Myra, do you want your usual two?” my mom asked as she measured the amount of water we would need for our cocoa into the cooking pot. I used to sigh so mournfully at the end of my cup that my mom would offer me the rest of hers. Soon, she realized she could just make me extra so that she didn’t have to sacrifice her own.

“Yes, please,” I replied.

After my mom had set the pot down on the flames, she stood up, handed a sandwich to my father and leaned in with the same motion to get a kiss on the lips.

“Nice fire,” she complimented.

GO ON TO THE NEXT PAGE.

My dad smiled in return, his face illuminated by firelight but projecting its own warmth. This time, the familiarity exchanged  
70 between my parents seemed like a wonderful gift they had earned by being together for so long. Like a river, their relationship maintained a constant appearance while the substance that flowed through it continually changed.

The river next to our campsite began to disappear into thicker  
75 darkness, while its sound continued throughout the night. Drifting off to sleep, I felt some peace knowing my worries would be carried away by the current.

- As it is used in line 3, the word *untainted* can reasonably be said to mean all of the following EXCEPT:
  - natural.
  - non-toxic.
  - undistorted.
  - true.
- The passage does NOT mention which of the following as something that at least one member of the family is doing?
  - Wading in the Wood River
  - Setting up a tent
  - Gathering pine needles
  - Igniting damp wood
- The narrator describes her father as doing all of the following EXCEPT:
  - sharing his hot cocoa with Myra during past camping excursions.
  - exuding a sense of warmth once the campfire is ignited.
  - describing to Myra a similarity between a river and a human body.
  - helping to gather materials for use with starting the campfire.
- The point of view from which the passage is told is best described as an adolescent girl who:
  - knows her father only has a limited amount of time left at his job and worries that her life will fall apart once his job ends.
  - hopes that her father's unemployment situation will have the upside of allowing her parents to repair their troubled marriage.
  - realizes that her father's job is in jeopardy but feels like he worries too much about things that are beyond his control.
  - recognizes the possibility of her father's unemployment and speculates about the effects it may have on the family.
- In order to help light a fire, the passage most strongly suggests that the family has gathered:
  - dry pine needles only.
  - dry pine needles and sticks only.
  - dry pine needles, sticks, and leaves only.
  - dry pine needles, sticks, leaves, and twigs.
- Which of the following does the narrator NOT directly mention as something seen during the earliest stages of dusk?
  - Shining water
  - Fish
  - Flowers
  - Trees
- When the narrator's mother hands her husband a sandwich and compliments him on the fire, the narrator reacts to this interaction with a feeling of familiarity that:
  - she often finds depressing.
  - distracts her from the river.
  - she worries will not last.
  - thoroughly comforts her.
- As it is used in line 33, the word *things* most precisely refers to:
  - 4th of July fireworks.
  - water boiling.
  - the campfire fully igniting.
  - the snaps and pops of kindling.
- As it is used in line 10, the word *flooded* most nearly means:
  - spilled.
  - devastated.
  - filled.
  - soaked.
- The narrator's statement in lines 49–51 most nearly means she believes her parents' relationship has:
  - not been the same since the threat of her father losing his job began to put a strain on their marriage.
  - become more stable and predictable than it was in the earlier part of their relationship.
  - degraded into something disease ridden and murky, like a mosquito infested pond.
  - somehow managed to grow more passionate and spontaneous with each passing year.

**GO ON TO THE NEXT PAGE.**



## Passage II

**SOCIAL SCIENCE:** This passage is adapted from the article, “When Charities Need Help” by Ellen Wurtner, (©2009 by Ellen Wurtner).

Traditionally, when people think of charitable giving, there are only a few images that spring to mind. They probably envision dropping change into the Salvation Army basket outside retail stores around the holidays, or into a basket passed around at their  
5 places of worship, or even into the hands of a homeless person whose pitiable appearance and humble request for “anything you can spare” is hard to deny. But can’t we do better?

Religious institutions have typically been the societal force that drives philanthropy. This is most likely because religion  
10 is vitally intertwined with morality, and charitable generosity has forever been exalted as one of the highest forms of moral behavior. Typically, churches collect alms for the poor at their church services and organize such hunger relief activities as soup kitchens.

Ted Stumbacher, head of the Global Empowerment Initiative, believes that truly effective philanthropy will need to have at its roots a more economic mindset. He feels religious organizations often provide only a temporary reprieve from suffering related to food, clothing, or shelter. While a noble end, this type of  
15 charity succeeds more in establishing a life-long commitment to philanthropy among the churchgoing public than it does in remedying any of the systemic problems that face the world’s impoverished masses.

Stumbacher points to several transformations taking place  
20 over the past two decades as harbingers of the new paradigm of philanthropic organizations. Some organizations are devoting increased attention to their marketing images, using meticulous branding and celebrity endorsements to solidify consumer awareness. Despite the fact that charities are nonprofit entities, they  
25 can still approach the task of maximizing their “market share” the way that other big corporations do. More commonly, nonprofits are finding non-monetary forms of assistance to tap, such as stationing clothing-recycling drop boxes around dense cities. These drop boxes not only allow used clothing to be funneled  
30 to those in need but also prevent needless environmental stress by keeping these textiles out of the world’s trash.

Similarly, Stumbacher notes the way charities are looking to increase the consumer choice aspect of giving. Rather than  
35 using the traditional model of citizens simply dropping money into a basket intended for some generic form of relief to the poor, organizations like Donors Choose are giving philanthropists much more decision-making power in how their money is used. The website for Donors Choose allows donors to sift through a list of  
40 charitable projects, enabling them to fund the cause they find most worthy. This model has proven to motivate giving by providing the giver with concrete imagery of where his money is going.

Other philanthropists, such as Karen Pitts, founder of Taste of Giving, say they are, “seeking to engage donors by merging  
45 their charitable giving with other activities they enjoy.” Ms. Pitts has organized wine tastings that successfully raise tens of thousands of dollars for charities. This is essentially a win-win-win situation. The wineries receive the excellent promotional context of a charitable event, the affluent wine drinkers are delighted to  
50 help others while enjoying themselves, and the charities enjoy a healthy slice of the financial proceeds.

Perhaps the most forward-minded approach is that of Jacqueline Novogratz, founder of the Acumen Fund. Endeavoring to extinguish poverty at its roots, the Acumen Fund collects  
55 donations in a typical way but then treats its pool of resources as investment capital. Instead of providing immediate relief of suffering, the Acumen Fund provides micro-loans to small businesses throughout third-world countries. Novogratz believes that this capitalistic approach is a more tenable form of long-term aid.

The old Chinese proverb, “give a man a fish and you’ll feed him for a day; teach a man to fish and you’ll feed him for a lifetime” seems to be at the root of Novogratz’s philosophy. By providing poor people with investment capital rather than food or clothing, she hopes to nourish and sustain them economically  
60 so that they can provide for themselves. Moreover, the Acumen Fund is a very hands-on enterprise, making regular inspections of the businesses they fund to verify that money is being spent shrewdly, efficiently, and honestly.

Unfortunately, what makes so many of these innovative  
65 philanthropic approaches inspiring and effective is their adaptation to the specific needs of their locales. Naysayers are quick to point out that these progressive business models will not be tenable on a large scale. As these ambitious charities grow with success, they may ultimately become lumbering organizational  
70 giants, such as UNICEF and the Rockefeller Foundation, and lose the flexibility, creativity, and personality that made them great.

However, even if these new tactics cannot be used in all contexts, they are still very valuable. By redefining what forms charity can take, these new approaches are widening the base of  
75 donors. By employing innovative methods, these philanthropic entrepreneurs are helping larger charitable organizations to reexamine and refine their own approach.

11. The passage indicates that in their attempt to promote philanthropy, religious institutions provide all of the following benefits or services EXCEPT:
- A. instructing homeless people on how to live moral lives.
  - B. collecting alms for the poor from churchgoers.
  - C. organizing events that feed those who are hungry.
  - D. providing temporary relief from suffering related to lack of shelter.

**GO ON TO THE NEXT PAGE.**

12. The author mentions clothing-recycling drop boxes and celebrity endorsements as two examples of:
- F. philanthropic approaches that are gaining popularity.
  - G. problems Stumbacher cites with modern philanthropy.
  - H. ways Karen Pitts has raised money for the needy.
  - J. the best way to reverse environmental problems.
13. The main function of the first paragraph is to:
- A. urge people to feel sympathy for and generosity towards homeless people.
  - B. cause the reader to picture himself in a charitable giving context.
  - C. discuss typical methods of charity and imply an alternative.
  - D. argue that the traditional methods of charity do nothing.
14. As described in the passage, philanthropy organized by religious institutions:
- F. provides solutions to systemic problems that cause poverty.
  - G. is an example of the highest form of morality.
  - H. is more flexible than efforts spearheaded by other nonprofit organizations are.
  - J. encourages long-term dedication to charity among those who attend church.
15. When Karen Pitts talks about “other activities they enjoy” (line 49), she is most likely referring to:
- A. finding positive promotional contexts for wineries in their community.
  - B. partaking in social events such as that of a wine tasting.
  - C. giving tens of thousands of dollars to charities that Pitts represents.
  - D. finding win-win opportunities with other donors in the wine industry.
16. The author most likely places the words “market share” in quotation marks in (line 30) to:
- F. suggest that only big corporations understand how to build a successful business model.
  - G. imply a different sense of market share from that of corporations seeking to maximize their profits.
  - H. emphasize that nonprofit entities must learn to coexist with each other to avoid collective failure.
  - J. caution readers that nonprofits can also sometimes attain a monopoly in their markets.
17. Stumbacher feels that “religious organizations often provide only a temporary reprieve from suffering” (lines 17–18) due to their:
- A. inability to boost the self-esteem of the impoverished.
  - B. failure to address the systemic roots of poverty.
  - C. overemphasis on noble ends.
  - D. lack of branding and celebrity endorsements.
18. According to the passage, which of the following is true about the practices of the Acumen Fund?
- F. Its method of distributing funds is less typical than its method of collecting funds.
  - G. It attempts but fails to treat the systemic roots of poverty.
  - H. It endeavors to temporarily relieve impoverished people of their suffering.
  - J. It collects most of its donations from small third-world businesses.
19. The passage mentions which of the following as a reason some innovative philanthropic approaches are effective?
- A. They integrate charity with activities the recipients enjoy.
  - B. They exalt charitable giving as one of the highest forms of moral behavior.
  - C. They are less expensive than traditional methods.
  - D. They can adapt to specific local needs.
20. In the context of the tenth paragraph (lines 81–86), the statement in lines 75–77 most nearly means that:
- F. new modes of providing charity will succeed only in large measures.
  - G. philanthropists do not have a realistic sense of the scale of some problems.
  - H. the value of innovative business models is not based on their ability to work globally.
  - J. progressive philanthropic approaches ultimately will not provide any benefit.

**GO ON TO THE NEXT PAGE.**

## Passage III

**HUMANITIES:** Passage A is adapted from “The Original Native Son” by Alain C. Tuppence. Passage B is adapted from “Their Eyes Were Watching Richard Wright” by Abel Cooper Tay.

## Passage A

Richard Wright’s achievement as an author is almost inconceivable. Although slavery ended in 1865, the period from the 1880s to the beginning of the Second World War in the 1940s might have been even worse for African-Americans in the United States. There was a certain additional cruelty to the fact that African-Americans had been given their freedom from bondage but were still isolated and alienated from American political and cultural life. Richard Wright managed to rise above this oppression to become the first major African-American writer and still one of the best loved.

Wright was born near Natchez, Mississippi, in 1908, and his early family life was tumultuous. His father left when he was 6, his mother was incapacitated with a stroke, and Richard moved in with his uncle. Because of all these moves and his family’s difficult economic circumstances, Richard did not complete a full year of school until he was 12 years old. The fact that he was valedictorian of his junior high only three years later is just one in a long string of truly stunning events in this exceptional man’s life.

Wright’s writing career also began around this time, when as a 15-year-old he published his first story, “The Voodoo of Hell’s Half-Acre,” in the *Southern Register*. In 1927, Wright left the south for Chicago, where he worked as a postal clerk and read the great works during free moments. Here he also became involved with the Communist Party, which was one of the more racially progressive institutions of the time. His association with left-wing politics brought him into contact with the work of Bertolt Brecht, a German playwright and theorist. The particular political slant of Brecht’s plays and essays shaped the course that Wright’s work would take in the next few years.

It was thus seemingly out of nowhere that Wright became an overnight success with the publication of his great novel *Native Son* in 1940. The novel’s reception exceeded any reasonable expectation for an African-American author of the time. Rising theater and film star Orson Welles bought the rights to bring the dramatized version of the book to stage and screen. The national Book of the Month Club selected *Native Son* in 1941, the first time in its then fifteen-year history that it had selected a book by an African-American author.

Wright’s career only grew larger from there. French celebrity philosopher Jean-Paul Sartre began to champion Wright’s works abroad, and *Native Son* was translated into many languages throughout the world. A boy with no formal schooling before the age of 12, whose race seemed to expressly forbid his access to the world of letters, that such a person could achieve Wright’s level of success and admiration, which have now outlived him by more than 50 years, is awe-inspiring.

## Passage B

No one will dispute that Richard Wright is a great author or that his success was groundbreaking. The idea, however, that Richard Wright emerged from some kind of void would be preposterous if it were not for the fact that Wright himself seemed to believe it. Studying Wright’s works can bear a good deal of fruit, but studying his life can lead us to only one conclusion: Wright was one of the greatest and most image-conscious strategists of 20th-century letters. His capacity for self-mythologizing rivals only that of Ernest Hemingway, whose adventurous, romantic lifestyle abroad continues to inspire many who read him, and just as many who don’t.

Although Richard Wright was clearly influenced by the works of white authors Gertrude Stein, Bertolt Brecht, and, of course, Karl Marx, he was also writing into a tradition of African-American literature that, by the 1930s, was over a century old. Wright’s story of his impoverished childhood and his sudden and full-fledged entry into the world of letters was actually a theme extending back to Frederick Douglass in the 1840s and Booker T. Washington in the 1890s. All three of these men achieved a kind of “freedom,” whether from slavery, sharecropping, or simply the oppressive shackles of race prejudice, through their education and literacy. Wright was surely cognizant of those who had come before him, but he must have been equally cognizant of the fact that citing them would dilute his own myth.

Then, as anyone familiar with early 20th century literature knows, Wright was publishing shortly after one of the greatest moments in African-American literature: the Harlem Renaissance. In fact, Wright was a vibrant presence within the Harlem scene. Indeed, the success of Wright’s first book *Uncle Tom’s Children* (1938) gave him the means to move to the epicenter of African-American culture, Harlem, New York. In fact, *Native Son*, that work we are led to believe had emerged from a vacuum, emerged from precisely this close contact Wright had with the other great minds of his generation.

Literary critics, in fact, should know better. Anyone who studies the history of African-American literature knows that it was critics themselves who were out of the loop, not the writers. Critics were unaware of Hurston’s *Their Eyes Were Watching God*, for instance, for forty years, and now it is universally acknowledged as one of the great books of the century. As a result, critics should know how self-serving this attitude of Wright’s should be, but they should also know how dreadfully wrong critics of the past had a tendency to be. Indeed, it was not that Wright was working in a void; it was instead that the critics themselves were unprepared, or downright unwilling, to see the rich tapestry of influences that had produced him.

**GO ON TO THE NEXT PAGE.**

Questions 21–23 ask about Passage A.

Questions 24–27 ask about Passage B.

21. The fourth paragraph of Passage A (lines 30–38) marks a shift in the passage from:
- A. an extended metaphor of the author’s difficulties to a literal description of his biography.
  - B. a discussion of the author’s background to a discussion of his public successes.
  - C. a biographical sketch to a piece of detailed literary criticism and analysis.
  - D. an analysis of the author’s motives to an explanation of the author’s results.
22. In Passage A, the author’s descriptions of Wright suggest that the author sees Wright as ultimately:
- F. impressive and brave.
  - G. troubled and derivative.
  - H. gifted and sociable.
  - J. shrewd and calculating.
23. The author of Passage A most nearly suggests that Bertolt Brecht was an important influence on Wright because Brecht:
- A. worked with Wright during Wright’s travels in Germany.
  - B. introduced Wright to national audiences and high-profile publishers.
  - C. inspired Wright to write in a particular way.
  - D. was one of the first people to introduce Wright to communism.
24. The author’s statement “Literary critics, in fact, should know better” (line 81) is most nearly meant to:
- F. indicate the author’s irritation with some critics for perpetuating a falsehood.
  - G. state the author’s approval of those who do not work in literary criticism.
  - H. support Wright’s bold claim that he worked entirely without influences.
  - J. reflect Wright’s position toward the literary establishment that analyzed his works.
25. Passage B indicates that compared to how Richard Wright has traditionally been understood within literary history, Wright’s context and influences were:
- A. dissimilar; Wright was exceptionally intelligent, but he had more formal schooling than was initially believed.
  - B. dissimilar; Wright did achieve a great deal, but he did not do so without influences and support.
  - C. similar; Wright was a brilliant author, and he worked with virtually no influences.
  - D. similar; Wright had a troubled childhood, and his writing explored and expressed his conflicted feelings.
26. Based on the passage, the information about *Their Eyes Were Watching God* provided in lines 83–85 is most likely meant to represent:
- F. the risk of pairing authors of fiction with their fictional characters.
  - G. the difficulty of identifying the sources of influence in the arts.
  - H. an example of the ways that critics can leave obvious gaps in literary history.
  - J. an author whose influence is much more powerful and more widely accepted than Wright’s.
27. According to the passage, Richard Wright is similar to Ernest Hemingway in that both authors:
- A. were misunderstood for many years by critics who were unaware of their works.
  - B. stated openly that they had no literary influences and no formal education.
  - C. wrote their greatest works shortly after the Harlem Renaissance.
  - D. had public personalities that were separate from the books they wrote.

**GO ON TO THE NEXT PAGE.**

Questions 28–30 ask about both passages.

28. Which of the following statements provides the most accurate comparison of the tone of each passage?
- F. Passage A is respectful and reverential, while Passage B is measured and skeptical.
  - G. Passage A is elated and amicable, while Passage B is pessimistic and contrarian.
  - H. Both passages begin artistic and loose but conclude with technical and precise arguments.
  - J. Both passages begin by doubting conventional wisdom but conclude by accepting that wisdom.
29. Compared to the author of Passage A, the author of Passage B provides more detail about:
- A. Wright's immediate context and professional strategy.
  - B. Wright's background and education.
  - C. the direct influences of Bertolt Brecht and Ernest Hemingway.
  - D. the contemporary political influences on Wright's life.
30. It can reasonably be inferred that when thinking about Richard Wright's success as an author, compared to the author of Passage B, the author of Passage A feels:
- F. less skeptical of how political events shape authors' professional lives.
  - G. less dismissive of the literary career of Ernest Hemingway.
  - H. more impressed that Wright was able to overcome his difficult past.
  - J. more neutral as to whether Wright's success could properly be called his own.

**GO ON TO THE NEXT PAGE.**

## Passage IV

**NATURAL SCIENCE:** This passage is adapted from the article “Unearthing the Greatest Fossil Ever Found” by Stanley Walsh, (©2009 by Stanley Walsh).

Evolutionary biologists can finally breathe a sigh of relief. Those who have been bursting at the seams to blurt out the “big secret” can finally shout it from the mountaintops, and those who have been hunting tirelessly for a “missing link” to solidify the Darwinian theory of evolution can finally rest easily.

The “big secret” and “missing link” are one and the same: a 47-million-year-old, uncannily preserved fossil of an ancient ancestor of the primate family, nicknamed *Ida*. After two years of secretly performing research on the fossil, experts are ready to present their findings to the world. They firmly believe that the lemur monkey they have preserved in polyester resin is conclusive evidence of a transitional species, a fork in the road where the genetic tree branches off in the direction that eventually gives rise to such simian species as monkeys, apes, and humans.

Two things make this particular specimen so valuable. It is older than any previously found primate fossil, vastly predating the previous record-holder, *Lucy*, which is a 3.18-million-year-old fossil. Furthermore, it is one of the most complete fossils ever found, with 95% of the skeleton preserved. In fact, the fossilization conditions were so perfect in *Ida*’s case that scientists could actually still analyze the last meal *Ida* had before apparently falling into a crater and dying of carbon dioxide poisoning. By contrast, *Lucy*’s remains were only 40% complete, lacking a skull among other important features.

Ironically, for such a monumentally important fossil, *Ida* has actually been flying under the radar for the past 25 years. An amateur fossil hunter first discovered her in 1983, in a volcanic crater-lake called the Messel Pit, just outside of Frankfurt, Germany. Because the Messel Pit was already considered a bountiful source of fossils, *Ida*’s discoverer did not assume there was anything distinctive about the discovery and hung *Ida* on his wall as a display piece for the next 20 years. He revered it as a piece of natural art, not recognizing its exceedingly old age as a fossil.

Eventually, the piece made its way to a display in the 2006 Hamburg Fossil and Mineral Fair in Germany. A researcher from Norway’s National History Museum, Professor Jorn Hurum, was immediately entranced upon seeing *Ida*. Unfortunately, his enthusiasm meant that the fossil dealer could charge an outlandish price of roughly 1 million dollars. Determined to secure this landmark specimen for the sake of scientific inquiry, Professor Hurum quickly raised the needed bounty and brought *Ida* home to Oslo, Norway.

For the next two years, a team of top scientists studied *Ida*’s features and attempted to integrate the information into the genetic tree of the primates. All the while, the scientists knew they were on the cusp of providing the most conclusive evidence

yet of the accuracy of Darwin’s theory of evolution. However, they had all signed non-disclosure agreements that prevented them from discussing these tentative findings with others in the field or the media.

Charles Darwin’s revolutionary book *The Origin of Species*, published in 1859, first detailed the theory of natural selection. It was extremely controversial in its time, and its contention that humans evolved from a lineage of monkeys remains an uncomfortable idea to many even to this day. Despite the 98.4% genetic similarity that humans have to chimpanzees, many of Darwin’s skeptics have routinely rested their cases on the fact that there was a gigantic hole in the fossil evidence that relates to where the branch of higher primates begins.

Around 50 million years ago, the first primates are thought to have emerged, two different species called *tarsidae* and *adapidae*. Scientists have been unsure which species ultimately led to the higher primates (monkeys and humans). The discovery of *Ida*, an *adapid* with several human-like features, suggests that *adapidae* are the ancestors of modern humans.

With so many anatomical features vividly preserved in *Ida*’s fossilized remains, scientists have been able to identify several telltale similarities *Ida* has to modern humans. One feature that distinguishes *Ida*’s species from non-anthropoid primates is the talus bone, a bone that turns the corner between the leg and the foot. Her eyes face forward, which makes her visual fields overlap, a requirement for accurate depth perception. Her hands and feet have nails, rather than claws, and opposable thumbs. Both characteristics allow for the use of appendages in a more refined way, whether it be peeling fruit, climbing, or, in the case of humans and their closer ancestors, using tools.

The debate over evolution is likely to continue for many years. However, the discovery of *Ida* has given evolutionary scientists a stronger supporting piece of evidence than they ever dreamed was possible. As Harold Zemeckels, a professor of evolutionary biology at Emerson University, puts it, “This fossil is essentially a prayer answered, a perfect time capsule that’s been miraculously gift-wrapped for posterity.”

31. The language of the first paragraph is most likely intended to convey a sense of:

- A. warning that a secret will be revealed.
- B. anguish for an ongoing scientific struggle.
- C. reluctance to accept a theory of evolution.
- D. anticipation for the topic the passage will discuss.

**GO ON TO THE NEXT PAGE.**

32. According to the passage, the “big secret” and the “missing link” refer to:
- F. Ida only.
  - G. Lucy only.
  - H. Ida, and the more recently discovered Lucy.
  - J. Lucy, and the more recently discovered Ida.
33. The passage characterizes the idea that Ida was a transitional species which later resulted in simians as:
- A. a conclusion that results from an extended period of studying the fossil.
  - B. a conclusion that stems from analyzing the polyester resin.
  - C. a speculation based on ruling out *tarsidae* as simian ancestors.
  - D. a speculation that springs from scientists’ desire to find a “missing link.”
34. The passage implies that the price that was paid to obtain Ida’s fossil from the private collector was:
- F. outlandish because Lucy, an even older fossil, was cheaper.
  - G. higher than is customary due to the buyer’s obvious interest.
  - H. unusual given how little the private collector valued it.
  - J. high due to its being discovered in a rare site for fossils.
35. In the passage, the amateur fossil hunter who found Ida in the Messel Pit is said to have:
- A. not immediately assumed Ida was special and so kept it for himself.
  - B. not immediately assumed Ida was special and so showed it to fellow scientists.
  - C. immediately assumed Ida was special and so brought it to the Fossil and Mineral Fair.
  - D. immediately assumed Ida was special and so brought it to Oslo, Norway.
36. Which of the following best summarizes the objection of those who remain skeptical of Darwin’s theory of evolution?
- F. 98.4% is not a close enough genetic similarity to suggest genetic relation.
  - G. They are uncomfortable with the idea that chimpanzees evolved from lemurs.
  - H. There are not enough fossils available that date before 1859.
  - J. There is some explanation missing as to how and when higher primates evolved.
37. The passage states that Lucy was not:
- A. at one point the oldest fossil known to man.
  - B. found in worse condition than was Ida.
  - C. found with a well preserved head.
  - D. only 40% complete as a fossil.
38. It can most reasonably be inferred that the word *enthusiasm* in line 38 refers to Professor Hurum’s enthusiasm for:
- F. the fossil dealer.
  - G. the specimen.
  - H. his home in Oslo.
  - J. the Fossil and Mineral Fair.
39. The author points out that scientists “could actually still analyze the last meal Ida had” (line 21) primarily to:
- A. foreshadow the valuable clues scientists derived from her last meal.
  - B. explain why comparatively little was learned from Lucy’s fossil.
  - C. underscore how well preserved Ida’s fossil was by its environment.
  - D. argue for a new theory on the diets of early primates.
40. As it relates to the passage, the eighth paragraph (lines 60–65) serves mainly to:
- F. explain the misconceptions that led some to doubt Darwin’s theory.
  - G. demonstrate the confusion that results from classifying ancient fossils.
  - H. illustrate a scientific context in which Ida’s fossil has proven helpful.
  - J. argue against the prevailing theory that humans came from *tarsidae*.

**END OF TEST 3**

**STOP! DO NOT TURN THE PAGE UNTIL TOLD TO DO SO.  
DO NOT RETURN TO A PREVIOUS TEST.**



## SCIENCE TEST

35 Minutes–40 Questions

**DIRECTIONS:** There are several passages in this test. Each passage is followed by several questions. After reading a passage, choose the correct answer to each question and fill in the corresponding oval on your answer document. You may refer to the passages as often as necessary.

You are NOT permitted to use a calculator on this test.

## Passage I

Hamsters forage and hoard many types of seeds and nuts. Scientists hypothesized that the European hamster (*Cricetus cricetus*) would be more drawn to hoard seeds soaked in certain fruit juices over seeds soaked in other fruit juices. Three experiments were performed to test this hypothesis.

## Experiment 1

Seeds from pumpkins (*Cucurbita pepa*) were soaked in juice from one of five different fruits (mango, lemon, coconut, apple, and orange) so that the seeds would absorb the fruit juice scent and flavor. The seeds were removed from the juice and dried, and 10 seeds soaked in each fruit juice were equally spaced throughout a glass cage. Then, a *C. cricetus* hamster that was recently captured in Belgium was placed in the center of the cage. Over the next 30 minutes, for each seed the hamster collected, the fruit juice in which it was soaked was recorded. For each seed the hamster placed in its cheek, an additional seed soaked in the same juice was added to the cage. This process was repeated with an additional 24 recently captured *C. cricetus* hamsters from Belgium. Figure 1 shows the average number of seeds collected from each type of fruit juice in 30 minutes.

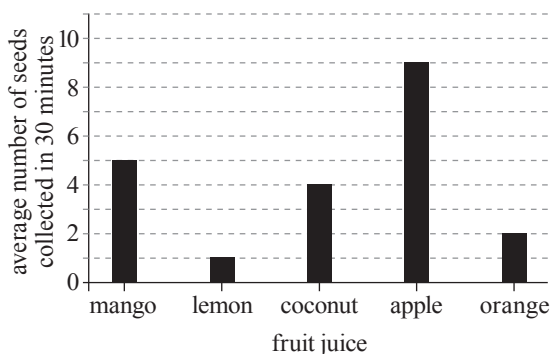

Figure 1

## Experiment 2

The procedure for Experiment 1 was repeated with the same set of 25 hamsters from Belgium, which had been kept in captivity in the research facility for 2 months. Figure 2 shows the average number of seeds collected from each type of fruit juice in 30 minutes.

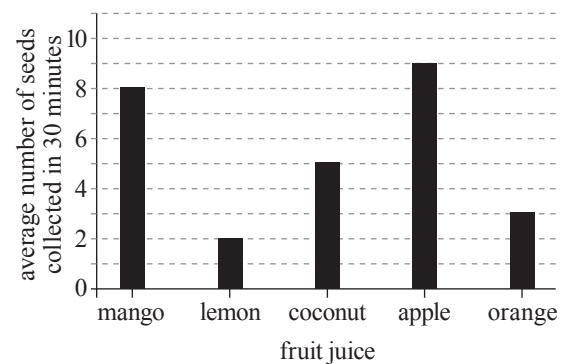

Figure 2

## Experiment 3

The procedure for Experiment 1 was repeated except with 25 recently captured *C. cricetus* hamsters from Russia. Figure 3 shows the average number of seeds collected from each type of fruit juice in 30 minutes.

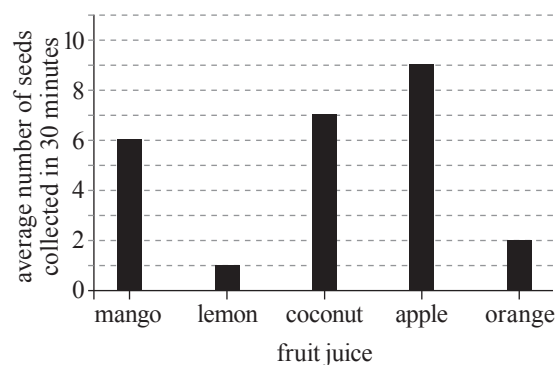

Figure 3

**GO ON TO THE NEXT PAGE.**





- Suppose that an additional experiment was performed in which the scientists repeated Experiment 1 except that they recorded the fruit juice of the seeds collected by the hamsters over ten minutes. Assuming that the hamsters collected seeds for the entirety of Experiment 1, would the total number of seeds collected in the new experiment more likely have been greater than or less than the total number of seeds collected in Experiment 1 ?
  - Greater, because the amount of time the hamsters spent collecting seeds would have been three times as great.
  - Greater, because the amount of time the hamsters spent collecting seeds would have been twice as great.
  - Less, because the amount of time the hamsters spent collecting seeds would have been one-half as great.
  - Less, because the amount of time the hamsters spent collecting seeds would have been one-third as great.
- Was the scientists' hypothesis supported by the results of the experiments?
  - No; in each experiment, on average, the hamsters collected more seeds soaked in apple juice than any other fruit juice in 30 minutes.
  - No; in each experiment, on average, the hamsters collected the same number of seeds soaked in each fruit juice in 30 minutes.
  - Yes; in each experiment, on average, the hamsters collected more seeds soaked in apple juice than any other fruit juice in 30 minutes.
  - Yes; in each experiment, on average, the hamsters collected the same number of seeds soaked in each fruit juice in 30 minutes.
- How many total hamsters were needed to complete Experiments 1–3 ?
  - 25
  - 40
  - 50
  - 75
- Which of the following experiments could be used to determine if the fruit juice preferences of recently captured European hamsters from Russia are the same for a different species of food source?
  - Repeat Experiment 2 with *C. pepa* as the food source.
  - Repeat Experiment 2 with a species other than *C. pepa* as the food source.
  - Repeat Experiment 3 with *C. pepa* as the food source.
  - Repeat Experiment 3 with a species other than *C. pepa* as the food source.
- Which of the following calculations was most likely used to calculate each of the values in Figure 3 ?
  - $$\frac{\text{Number of seeds of each fruit juice collected by hamsters from Russia}}{\text{Number of hamsters from Russia}}$$
  - $$\frac{\text{Number of seeds of each fruit juice collected by hamsters from Belgium}}{\text{Number of hamsters from Belgium}}$$
  - $$\frac{\text{Total number of seeds collected by hamsters from Russia}}{\text{Number of hamsters from Russia}}$$
  - $$\frac{\text{Total number of seeds collected by hamsters from Belgium}}{\text{Number of hamsters from Belgium}}$$
- Which of the following statements regarding the hamsters used in Experiments 1 and 3 is consistent with the information provided in the passage?
  - The hamsters used in Experiment 1 are neither members of the same genus nor species as those used in Experiment 3.
  - The hamsters used in Experiment 1 are members of the same genus as those used in Experiment 3, but they are not members of the same species.
  - The hamsters used in Experiment 1 are members of the same species as those used in Experiment 3, but they are not members of the same genus.
  - The hamsters used in both Experiments 1 and 3 are members of the same genus and species.
- Which of the following statements is most consistent with the results of Experiments 1 and 2 ? After the captured hamsters from Belgium spent 2 months in captivity, they collected, on average:
  - fewer seeds in 30 minutes than did the recently captured hamsters from Russia.
  - more seeds in 30 minutes than they did when they were recently captured.
  - fewer apple juice soaked seeds in 30 minutes than did the recently captured hamsters from Russia.
  - more apple juice soaked seeds in 30 minutes than they did when they were recently captured.

**GO ON TO THE NEXT PAGE.**

### Passage II

Dye-sensitized solar cells (DSSCs) are a cost-effective way of producing electricity from sunlight. One advantage of DSSCs compared to other types of solar cells is that they are composed of readily available materials, such as titanium dioxide. Scientists studied the effectiveness of DSSCs using mixtures of two metal oxides.

#### Experiment

In each trial, the following steps were performed:

1. A mixture of titanium dioxide ( $\text{TiO}_2$ ) and zinc oxide ( $\text{ZnO}$ ) was combined with 20 mL dilute nitric acid in a 100 mL beaker and stirred to form a paste.
2. The paste was applied with a spatula to a negative electrode made of a conductive glass slide and then left to dry for 10 minutes.
3. The coated glass slide was placed into a preheated oven and heated at a high temperature for 5 minutes, then removed from the oven and left to cool for 1 hour.
4. Blackberry juice, a dark-colored natural dye, was applied to the side of the glass slide containing the oxide paste and left to dry for 30 minutes until the dye was adsorbed onto the oxide surface.
5. A positive electrode made of glass coated with graphite was pressed onto the dye-coated slide.
6. The two electrodes were connected by wires to the two ends of a multimeter and the assembly was exposed to sunlight to measure the *conversion efficiency*, the energy produced by the cell as a percentage of the total incident solar energy.

For any given combination of conditions (identity of primary oxide, concentration of secondary oxide, and heating temperature), 3 trials were conducted. The table shows, for each set of trials, the experimental conditions and the average conversion efficiency of the solar cells.

Set of trials	Primary oxide	Concentration of secondary oxide (% by mass)	Temperature ( $^{\circ}\text{C}$ )	Average conversion efficiency (%)
1–3	$\text{TiO}_2$	10	400	14.4
4–6	$\text{TiO}_2$	20	400	12.6
7–9	$\text{TiO}_2$	40	400	10.7
10–12	$\text{ZnO}$	10	400	5.6
13–15	$\text{ZnO}$	20	400	7.0
16–18	$\text{ZnO}$	40	400	9.2
19–21	$\text{TiO}_2$	20	300	9.5
22–24	$\text{TiO}_2$	20	500	15.9
25–27	$\text{TiO}_2$	20	600	17.8
28–30	$\text{ZnO}$	20	300	6.1
31–33	$\text{ZnO}$	20	500	9.4

8. Which step was most likely performed to ensure that the solar cell would absorb a sufficient amount of sunlight once it was exposed to light?
  - F. Step 1
  - G. Step 2
  - H. Step 3
  - J. Step 4
9. According to the table, which combination of primary oxide, concentration of secondary oxide, and temperature resulted in the *lowest* average conversion efficiency?

- |    | primary oxide  | secondary oxide concentration | temperature           |
|----|----------------|-------------------------------|-----------------------|
| A. | $\text{TiO}_2$ | 20%                           | $300^{\circ}\text{C}$ |
| B. | $\text{TiO}_2$ | 20%                           | $400^{\circ}\text{C}$ |
| C. | $\text{ZnO}$   | 40%                           | $400^{\circ}\text{C}$ |
| D. | $\text{ZnO}$   | 20%                           | $500^{\circ}\text{C}$ |

**GO ON TO THE NEXT PAGE.**



10. Consider the results for each combination of secondary oxide concentration and temperature that was tested. Compared with the average conversion efficiency in the ZnO trials, the average conversion efficiency in the TiO<sub>2</sub> trials was:
- F. always higher.
  - G. always lower.
  - H. always the same.
  - J. sometimes higher and sometimes lower.
11. Which of the following gives the volume of dilute nitric acid used in the experiment?
- A.  $11 \text{ trials} \times \frac{(20 \text{ mL nitric acid})}{\text{trial}}$
  - B.  $11 \text{ trials} \times \frac{(100 \text{ mL nitric acid})}{\text{trial}}$
  - C.  $33 \text{ trials} \times \frac{(20 \text{ mL nitric acid})}{\text{trial}}$
  - D.  $33 \text{ trials} \times \frac{(100 \text{ mL nitric acid})}{\text{trial}}$
12. The average conversion efficiency in Trials 4–6 differed from that in Trials 19–21 because the 2 sets of trials differed with respect to the:
- F. identity of the primary oxide.
  - G. concentration of the secondary oxide.
  - H. temperature.
  - J. time for which the slide was heated.
13. For the trials conducted with TiO<sub>2</sub> as the primary oxide and 20% secondary oxide by mass, as the temperature increased, the average conversion efficiency:
- A. decreased only.
  - B. increased only.
  - C. decreased and then increased.
  - D. increased and then decreased.
14. The mixture formed in Step 1 of each trial had a mass of 21 g. Based on this information and the table, the mass of the secondary oxide added to the mixture in Step 1 of Trial 14 was closest to which of the following?
- F. 0.2 g
  - G. 0.4 g
  - H. 2 g
  - J. 4 g

GO ON TO THE NEXT PAGE.

**Passage III**

In order to estimate the irrigation needs, groundwater recharge rates, and flash flood risks for a region, it is necessary to examine the distribution of precipitation throughout the year. A researcher calculated the total precipitation over each 5-day period for a year in 9 cities. When the 5-day precipitation,  $P_5$ , exceeded the North American average of 10 mm, the 5-day excess (FDE) was calculated by subtracting 10 mm from  $P_5$ . When  $P_5$  was less than 10 mm, the 5-day shortfall (FDS) was calculated by subtracting  $P_5$  from 10 mm.

Table 1 lists the longitude, the sum of the FDE values, and the sum of the FDS values for the year 2018 for 9 North American cities.

City	Longitude	Annual sum of:	
		FDE (mm)	FDS (mm)
Philadelphia, PA	75.17° W	1,158	205
Toronto, ON	79.38° W	522	323
New Orleans, LA	90.07° W	1,068	233
Oklahoma City, OK	97.52° W	501	474
Cheyenne, WY	104.82° W	189	461
Tucson, AZ	110.97° W	167	536
Boise, ID	116.20° W	69	528
Reno, NV	119.81° W	107	553
San Francisco, CA	122.42° W	232	570

Note: FDE =  $P_5 - 10$  mm for all  $P_5 > 10$  mm;  
FDS =  $10$  mm -  $P_5$  for all  $P_5 < 10$  mm

For the city of New Orleans, the annual sums of both the FDE values and FDS values were determined for each of the years 1995–2015 (see Figure 1).

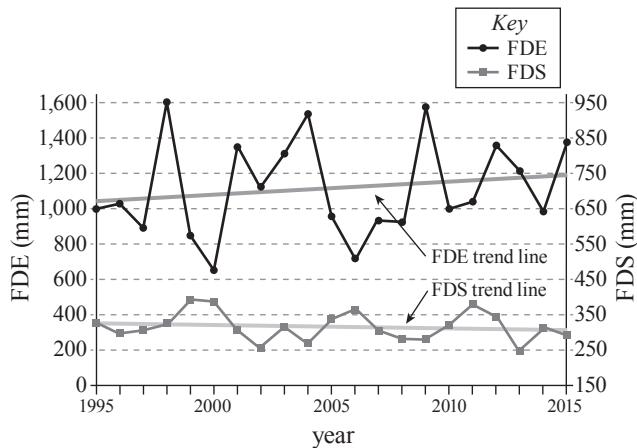

Figure 1

- According to Figure 1, did the maximum FDE occur during the same year as the minimum FDS ?
  - Yes; the maximum FDE and the minimum FDS both occurred in 1998.
  - Yes; the maximum FDE and the minimum FDS both occurred in 2013.
  - No; the maximum FDE occurred in 1998, whereas the minimum FDS occurred in 2013.
  - No; the maximum FDE occurred in 2013, whereas the minimum FDE occurred in 1998.
- Based on Table 1, in Tucson, the total FDS was approximately how many times as great as the total FDE ?
  - $\frac{1}{6}$
  - $\frac{1}{3}$
  - 3
  - 6
- Based on Table 1, for all the cities between 95° W and 120° W longitude, which of the following statements describing FDE or FDS is accurate? In 2018, the total:
  - FDE was always greater than the total FDS.
  - FDE was always greater than 100.
  - FDS was always greater than the total FDE.
  - FDS was always greater than 450.
- For a particular 5-day period, the  $P_5 = 10$  mm. For this period, what FDE value would be calculated and what FDS value would be calculated?

	FDE	FDS
F.	-1	1
G.	0	0
H.	1	0
J.	1	1

**GO ON TO THE NEXT PAGE.**



19. Which of the following graphs best illustrates the longitude and the FDE for each of the cities listed in Table 1 ?

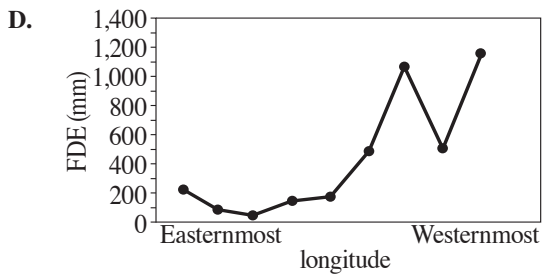
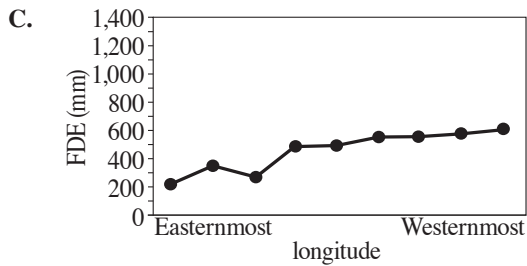
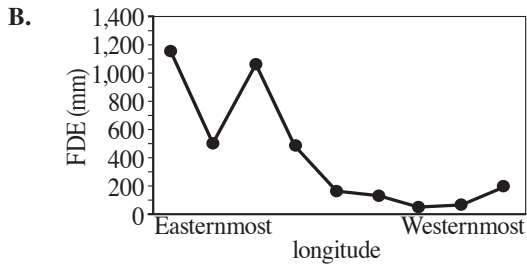
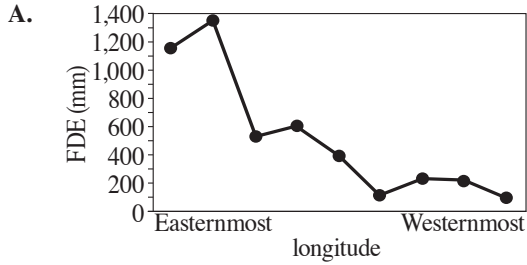

20. Consider the FDS equation and the FDS trend line shown in Figure 1. The slope of the trend line is negative, which indicates that, over the 21 yr period, the average value of  $P_5$ :

- F. increased only.
- G. decreased only.
- H. remained constant.
- J. increased then decreased.

**GO ON TO THE NEXT PAGE.**

### Passage IV

The plant *Toxicodendron vernix* can cause contact dermatitis. Scientists conducted 2 experiments to study the *herbicidal* (plant-killing) activity of a particular natural weed killer.

#### Experiment 1

One hundred liters of an *aqueous solution* (AS) that was 10% NaCl by volume was sprayed onto a 5 m by 5 m square plot of land containing 50 *T. vernix* plants. This procedure was performed twice more on two additional plots of land, except that the percents by volume of NaCl were 20% and 30%, respectively. One hundred liters of pure distilled water was sprayed on a fourth plot of land. Next, a second set of land plots was similarly prepared, except that weed killer was substituted for NaCl. All 8 plots of land were exposed to 3 hours of sunlight at the same intensity and then covered with tarps. The land plots were then observed again after 2 days, and the *percent survival* (percent of the *T. vernix* that were still alive) was determined for each land plot.

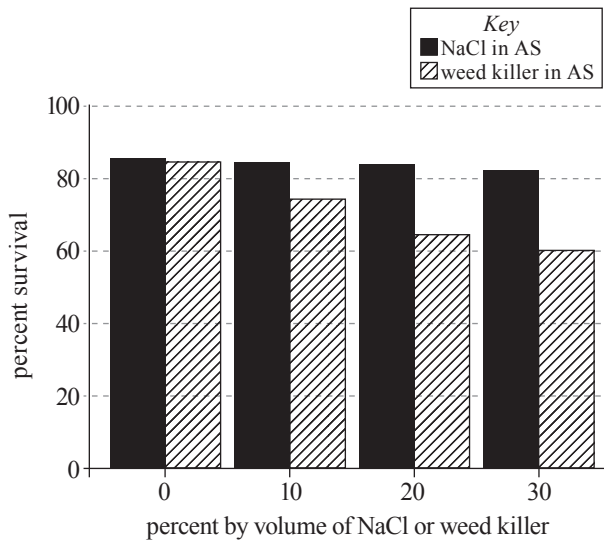

Figure 1

#### Experiment 2

A sample of the weed killer was separated into its three ingredients: corn gluten, *glycerol* (a sugar alcohol), and vinegar. One hundred liters of an AS that was 35% NaCl by volume was sprayed onto a 5 m by 5 m square plot of land containing 50 *T. vernix* plants. This process was repeated 3 times, except that each time a different ingredient from the weed killer was substituted for NaCl. Then, 2 more sets of 4 land plots were similarly treated. Each set of 4 land plots was exposed to sunlight of the same intensity for a different number of hours: 6 hours, 12 hours, 18 hours. After 2 days, the percent survival was determined for each plot (see Figure 2).

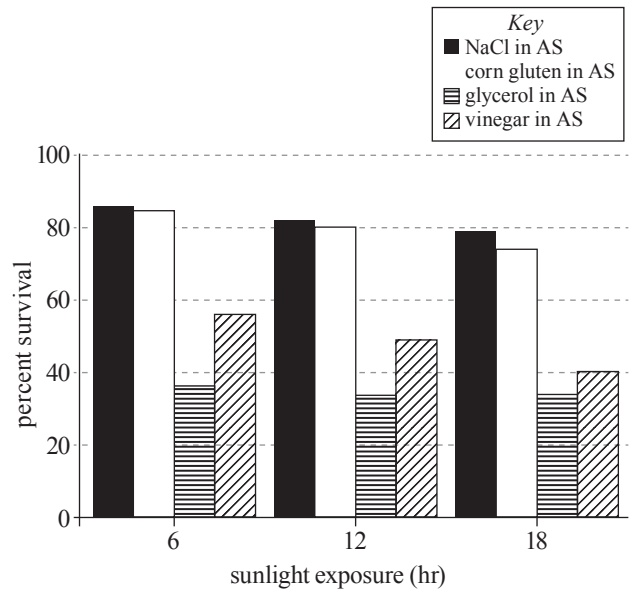

Figure 2

21. In Experiment 2, at each sunlight exposure, which AS mixture resulted in the *fewest* surviving *T. vernix*?
  - A. NaCl in AS
  - B. Corn gluten in AS
  - C. Glycerol in AS
  - D. Vinegar in AS
22. Suppose that the percent survival had been documented after 24 hours of sunlight exposure in Experiment 2. The percent survival of the *T. vernix* in the plot of land that was sprayed with glycerol in AS would most likely have been closest to which of the following values?
  - F. 5%
  - G. 35%
  - H. 45%
  - J. 65%
23. In Experiment 2, for which of the sunlight exposures did the scientists include a control to determine whether a substantial decrease in *T. vernix* survival occurred in the absence of a natural weed killer ingredient?
  - A. 6 hours only
  - B. 12 hours only
  - C. 18 hours only
  - D. All 3 sunlight exposures

**GO ON TO THE NEXT PAGE.**



24. In Experiment 1, which of the following questions were the researchers most likely attempting to answer?
- F. Does the percent survival for *T. vernix* sprayed with corn starch differ from the percent survival for *T. vernix* sprayed with glycerol?
  - G. Does the percent survival for *T. vernix* sprayed with weed killer differ from the percent survival for *T. vernix* sprayed with NaCl ?
  - H. Is the percent survival of *T. vernix* sprayed with NaCl and *T. vernix* sprayed with vinegar affected by increasing the sunlight exposure from 3 hours to 6 hours?
  - J. Is the percent survival of *T. vernix* sprayed with NaCl and *T. vernix* sprayed with weed killer affected by increasing the sunlight exposure from 3 hours to 6 hours?
25. In Experiment 1, the scientists used a knife to make a 1 cm cut into the *cambium layer* of each plant. Living *T. vernix* have a green cambium layer; dead *T. vernix* do not. Approximately what percent of the *T. vernix* in the plot of land that was sprayed with 10% weed killer in AS did not have a green cambium layer?
- A. 25%
  - B. 35%
  - C. 75%
  - D. 80%
26. To best compare the herbicidal ability of each of the 3 natural weed killer ingredients tested in Experiment 2 to the herbicidal ability of natural weed killer that has not been separated into its ingredients, the scientists should repeat the procedures of:
- F. Experiment 1, except include a plot of land sprayed with weed killer in AS for each set of land plots.
  - G. Experiment 1, except include a plot of land sprayed with a glycerol in AS for each set of land plots.
  - H. Experiment 2, except include a plot of land sprayed with weed killer in AS for all three days.
  - J. Experiment 2, except include a plot of land sprayed with glycerol in AS for all three days.
27. A *T. vernix* cell possesses which of the following sets of characteristics?
- A. Has a nucleus; has a cell wall
  - B. Has a nucleus; does not have a cell wall
  - C. Does not have a nucleus; has a cell wall
  - D. Does not have a nucleus; does not have a cell wall

**GO ON TO THE NEXT PAGE.**

**Passage V**

To demonstrate static electricity, a teacher had students suspend 2 identical acrylic bars from each of 3 wooden beams. Then, the students rubbed each acrylic bar with a piece of fabric (either silk cloth or faux fur) as shown in Figure 1.

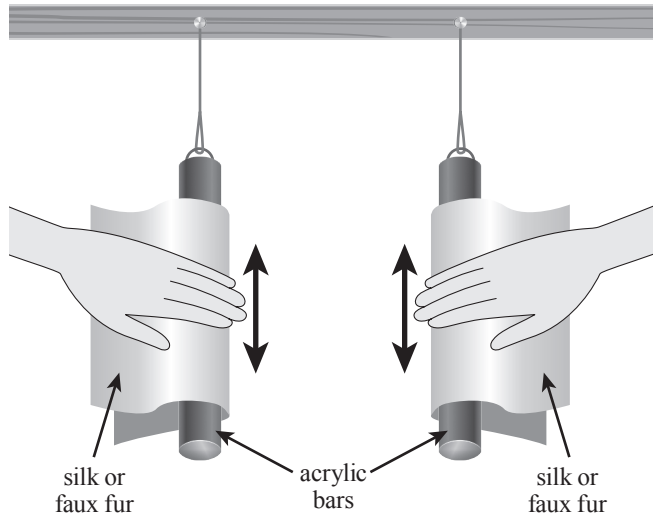

Figure 1

On the first beam, a student used a silk cloth on both bars, and the bars moved away from each other. On the second beam, a student used a piece of faux fur on both bars, and the bars moved away from each other. On the last beam, a student used a piece of silk cloth on the acrylic bar on the left and faux fur on the acrylic bar on the right, and the bars moved towards each other. See Figure 2.

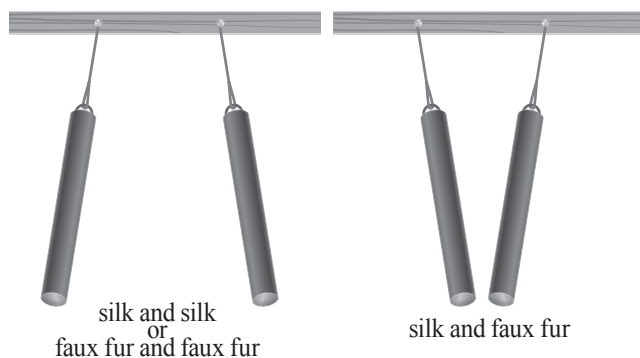

Figure 2

The teacher asked each of 3 students to explain these results.

**Student 1**

Rubbing the acrylic bar with a piece of fabric generated static electricity because negatively charged subatomic particles were transferred between the two materials. The type of fabric affected

the direction of transfer: negative charges were transferred out of the bar to the silk and into the bar from the faux fur.

In an atom, the positive charges are contained in the nucleus, while the negative charges orbit the nucleus. When two materials come into contact, the negative charges can move from the atoms on one material to the atoms on the other material, creating both positively and negatively charged ions. Ions of like charges repel each other, while ions of opposite charges attract each other.

**Student 2**

Static electricity was generated, and the type of fabric affected the direction of transfer as Student 1 said, except that the charges transferred were positive.

When two materials come into contact, the positive charges can move from the atoms on one material to the atoms on the other material. The material that receives positive charges will contain positive ions that are attracted to negative ions and repulsed by other positive ions. The material that loses positive charges will form negative ions that are attracted to positive ions and repulsed by other negative ions.

**Student 3**

Static electricity was created when charged ions transferred from one material to the other.

Silk has a lot of positive ions, so when the silk cloth was rubbed on the bar, some of these positive ions transferred onto the bar. Faux fur, on the other hand, has a lot of negative ions, so when the faux fur was rubbed on a bar, some of the negative ions were transferred onto the bar. Ions of like charges repel each other, while ions of opposite charges attract each other.

28. Which of the following statements, each of which was stated by or implied by Student 2, is scientifically *inaccurate*?
- F. Rubbing two materials together can generate static electricity.
  - G. Charges of like sign are repulsed by each other.
  - H. Ions can be either positively or negatively charged.
  - J. The subatomic particles that orbit the nucleus of an atom are positively charged.
29. Assume that an individual atom on the acrylic bar becomes charged after the transfer of a charged particle from an atom on the faux fur. If Student 1's explanation is correct, the charged particle transferred to the atom on the bar was most likely:
- A. an electron.
  - B. a proton.
  - C. a photon.
  - D. a neutron.

**GO ON TO THE NEXT PAGE.**





30. If Student 1's explanation is correct, then a neutral atom has:
- F. more positive charges orbiting the nucleus than negative charges inside the nucleus.
  - G. fewer negative charges orbiting the nucleus than positive charges inside the nucleus.
  - H. the same number of positive charges orbiting the nucleus as negative charges inside the nucleus.
  - J. the same number of negative charges orbiting the nucleus as positive charges inside the nucleus.
31. Based on Student 1's explanation, when a silk cloth was used on the acrylic bar on the left and faux fur was used on the acrylic bar on the right, did the bars experience an attractive or repulsive force towards each other?
- A. Attractive, because negative charges moved into the bar on the left and charges moved out of the bar on the right.
  - B. Attractive, because the negative charges moved out of the bar on the left moved into the bar on the right.
  - C. Repulsive, because negative charges moved into both bars.
  - D. Repulsive, because negative charges moved out of both bars.
32. Which of the following figures is consistent with both Student 3's explanation and Figure 2?

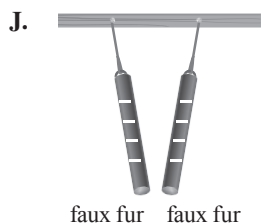
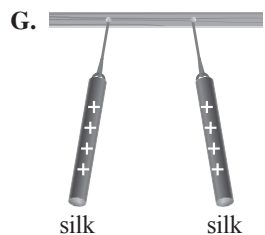
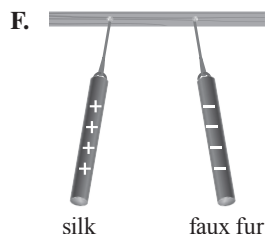

- A. either positively or negatively charged subatomic particles are transferred, while Student 3 believes that only positive ions are transferred.
  - B. either positively or negatively charged ions are transferred, while Student 3 believes only positive subatomic particles are transferred.
  - C. only positively charged subatomic particles are transferred, while Student 3 believes either positive or negative ions are transferred.
  - D. only positive ions are transferred, while Student 3 believes that either positive or negatively charged subatomic particles are transferred.
34. Which of the following procedures would best test Student 3's explanation? Using the same types of fabric as used in the three experiments, determine if:
- F. a piece of silk cloth and a piece of faux fur that have not yet been used on the acrylic bars move towards each other when held near each other.
  - G. a piece of silk cloth that has not yet been used on the acrylic bars moves towards an uncharged acrylic bar when held near it.
  - H. a piece of faux fur that has not yet been used on the acrylic bars moves towards an uncharged acrylic bar when held near it.
  - J. two pieces of silk cloth and faux fur that have already been in contact with the acrylic bars move towards an uncharged acrylic bar when held near it.

**GO ON TO THE NEXT PAGE.**



## Passage VI

Figure 1 shows how an aqueous solution's *resistivity* (a measure of a material's ability to resist electrical current) varies with its electrical conductivity. Figure 2 shows how the current produced by a particular battery at room temperature (20 °C) varies with the resistivity of the aqueous solution used in the battery.

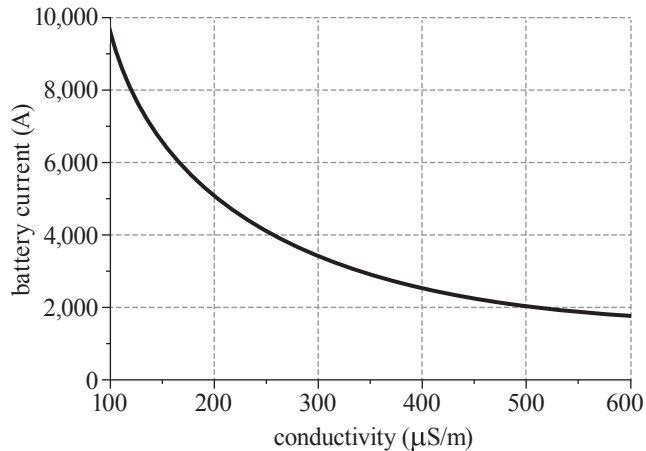

Figure 1

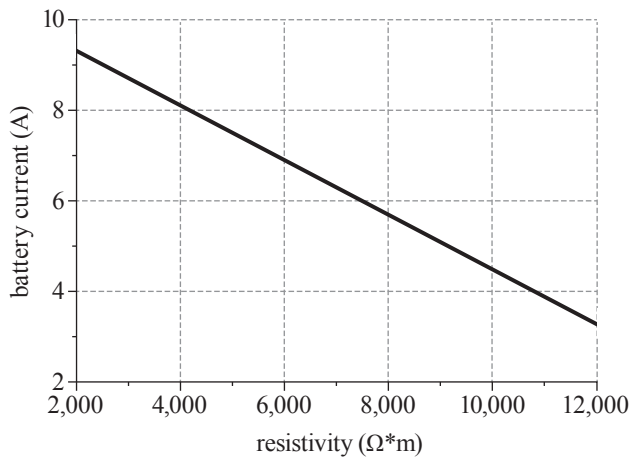

Figure 2

At room temperature, an aqueous solution has a constant electrical conductivity. Figure 3 shows, for 3 salts, how the electrical conductivities of aqueous solutions at room temperature vary with the molar concentrations of the dissolved salts.

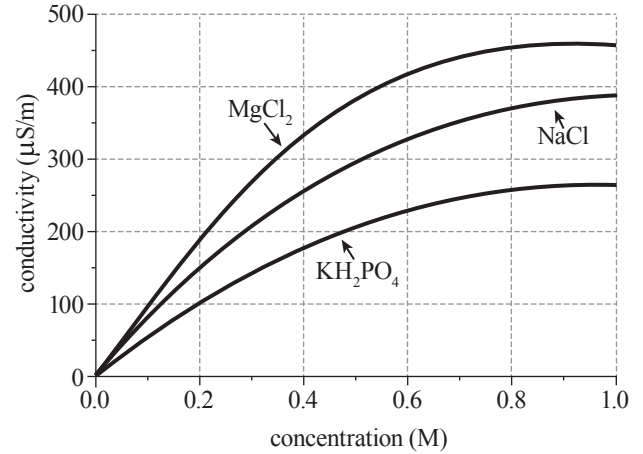

Figure 3

35. Based on Figures 1 and 2, as conductivity increases from 200  $\mu\text{S/m}$  to 500  $\mu\text{S/m}$  at room temperature, battery current:
- decreases only.
  - increases only.
  - decreases, then increases.
  - increases, then decreases.
36. Based on Figure 2, a battery that produces a current of 2 A will contain an aqueous solution with a resistivity closest to which of the following?
- 10,000  $\Omega\cdot\text{m}$
  - 12,000  $\Omega\cdot\text{m}$
  - 14,000  $\Omega\cdot\text{m}$
  - 16,000  $\Omega\cdot\text{m}$

GO ON TO THE NEXT PAGE.



37. According to Figure 3, at room temperature, pure  $\text{H}_2\text{O}$  has a conductivity of:
- A.  $0 \mu\text{S/m}$ .
  - B.  $200 \mu\text{S/m}$ .
  - C.  $400 \mu\text{S/m}$ .
  - D.  $500 \mu\text{S/m}$ .
38. Based on Figure 2, will the battery supply more power if it contains a solution with a resistivity of  $5,000 \Omega\cdot\text{m}$  or  $10,000 \Omega\cdot\text{m}$ ?
- F.  $5,000 \Omega\cdot\text{m}$ , because it will produce a higher current.
  - G.  $5,000 \Omega\cdot\text{m}$ , because it will produce a lower current.
  - H.  $10,000 \Omega\cdot\text{m}$ , because it will produce a higher current.
  - J.  $10,000 \Omega\cdot\text{m}$ , because it will produce a lower current.
39. Consider a battery containing a  $0.5 \text{ M}$  aqueous solution of  $\text{MgCl}_2$ . Based on Figures 1–3, if the battery is at room temperature, the current produced by the battery will be closest to which of the following?
- A.  $0 \text{ A}$
  - B.  $2 \text{ A}$
  - C.  $7 \text{ A}$
  - D.  $9 \text{ A}$
40. Consider two  $0.2 \text{ M}$  aqueous solutions, one of  $\text{MgCl}_2$  and one of  $\text{KH}_2\text{PO}_4$ , each kept at room temperature. A student claimed that the  $\text{KH}_2\text{PO}_4$  solution will have a higher resistivity than the  $\text{MgCl}_2$  solution. Do Figures 1 and 3 support this claim?
- F. Yes, because a lower conductivity results from the  $\text{MgCl}_2$  solution.
  - G. Yes, because a lower conductivity results from the  $\text{KH}_2\text{PO}_4$  solution.
  - H. No, because a lower conductivity results from the  $\text{MgCl}_2$  solution.
  - J. No, because a lower conductivity results from the  $\text{KH}_2\text{PO}_4$  solution.

**GO ON TO THE NEXT PAGE.**