



Part II
Practice Test 1

AP[®] Chemistry Exam

SECTION I: Multiple-Choice Questions

DO NOT OPEN THIS BOOKLET UNTIL YOU ARE TOLD TO DO SO.

At a Glance

Total Time

1 hour and 30 minutes

Number of Questions

60

Percent of Total Grade

50%

Writing Instrument

Pencil required

Instructions

Section I of this examination contains 60 multiple-choice questions. Fill in only the ovals for numbers 1 through 60 on your answer sheet.

CALCULATORS MAY NOT BE USED IN THIS PART OF THE EXAMINATION.

Indicate all of your answers to the multiple-choice questions on the answer sheet. No credit will be given for anything written in this exam booklet, but you may use the booklet for notes or scratch work. After you have decided which of the suggested answers is best, completely fill in the corresponding oval on the answer sheet. Give only one answer to each question. If you change an answer, be sure that the previous mark is erased completely. Here is a sample question and answer.

Sample Question

Chicago is a
(A) state
(B) city
(C) country
(D) continent

Sample Answer

(A) ● (C) (D)

Use your time effectively, working as quickly as you can without losing accuracy. Do not spend too much time on any one question. Go on to other questions and come back to the ones you have not answered if you have time. It is not expected that everyone will know the answers to all the multiple-choice questions.

About Guessing

Many candidates wonder whether or not to guess the answers to questions about which they are not certain. Multiple-choice scores are based on the number of questions answered correctly. Points are not deducted for incorrect answers, and no points are awarded for unanswered questions. Because points are not deducted for incorrect answers, you are encouraged to answer all multiple-choice questions. On any questions you do not know the answer to, you should eliminate as many choices as you can, and then select the best answer among the remaining choices.

CHEMISTRY
SECTION I

Time—1 hour and 30 minutes

INFORMATION IN THE TABLE BELOW AND ON THE FOLLOWING PAGES MAY BE USEFUL IN ANSWERING THE QUESTIONS IN THIS SECTION OF THE EXAMINATION.

DO NOT DETACH FROM BOOK.

PERIODIC TABLE OF THE ELEMENTS

1	H 1.008												2	He 4.00																							
3	Li 6.94	Be 9.01												9	F 19.00	10	Ne 20.18																				
11	Na 22.99	Mg 24.30												16	S 32.06	17	Cl 35.45	18	Ar 39.95																		
19	K 39.10	Ca 40.08	Sc 44.96	Ti 47.90	V 50.94	Cr 52.00	Mn 54.94	Fe 55.85	Co 58.93	Ni 58.69	Cu 63.55	Zn 65.39	Ga 69.72	Ge 72.59	As 74.92	Se 78.96	Br 79.90	Kr 83.80																			
37	Rb 85.47	Sr 87.62	Y 88.91	Zr 91.22	Nb 92.91	Mo 95.94	Tc (98)	Ru 101.1	Rh 102.91	Pd 106.42	Ag 107.87	Cd 112.41	In 114.82	Sn 118.71	Sb 121.75	Te 127.60	I 126.91	Xe 131.29																			
55	Cs 132.91	Ba 137.33	*La 138.91	Hf 178.49	Ta 180.95	W 183.85	Re 186.21	Os 190.2	Ir 192.2	Pt 195.08	Au 196.97	Hg 200.59	Tl 204.38	Pb 207.2	Bi 208.98	Po (209)	At (210)	Rn (222)																			
87	Fr (223)	Ra 226.02	†Ac 227.03	Rf (261)	Db (262)	Sg (266)	Bh (264)	Hs (277)	Mt (268)	Ds (271)	Rg (272)																										
														65	Tb 158.93	66	Dy 162.50	67	Ho 164.93	68	Er 167.26	69	Tm 168.93	70	Yb 173.04	71	Lu 174.97										
														91	Th 232.04	92	Pa 231.04	93	Np 237.03	94	Pu 244.03	95	Am 243.03	96	Cm 247.03	97	Bk 247.03	98	Cf 251.03	99	Es 252.03	100	Fm 257.03	101	No 259.03	102	Lr 262.03
														*Lanthanide Series												†Actinide Series											

GO ON TO THE NEXT PAGE.

ADVANCED PLACEMENT CHEMISTRY EQUATIONS AND CONSTANTS

Throughout the test the following symbols have the definitions specified unless otherwise noted.

L, mL = liter(s), milliliter(s)
 g = gram(s)
 nm = nanometer(s)
 atm = atmosphere(s)

mm Hg = millimeters of mercury
 J, kJ = joule(s), kilojoule(s)
 V = volt(s)
 mol = mole(s)

ATOMIC STRUCTURE

$$E = h\nu$$

$$c = \lambda\nu$$

E = energy
 ν = frequency
 λ = wavelength

Planck's constant, $h = 6.626 \times 10^{-34}$ J sSpeed of light, $c = 2.998 \times 10^8$ m s⁻¹Avogadro's number = 6.022×10^{23} mol⁻¹Electron charge, $e = -1.602 \times 10^{-19}$ coulomb

EQUILIBRIUM

$$K_c = \frac{[C]^c[D]^d}{[A]^a[B]^b}, \text{ where } aA + bB \rightleftharpoons cC + dD$$

$$K_p = \frac{(P_C)^c(P_D)^d}{(P_A)^a(P_B)^b}$$

$$K_a = \frac{[H^+][A^-]}{[HA]}$$

$$K_b = \frac{[OH^-][HB^+]}{[B]}$$

$$K_w = [H^+][OH^-] = 1.0 \times 10^{-14} \text{ at } 25^\circ\text{C}$$

$$= K_a \times K_b$$

$$\text{pH} = -\log[H^+], \text{ pOH} = -\log[OH^-]$$

$$14 = \text{pH} + \text{pOH}$$

$$\text{pH} = \text{p}K_a + \log \frac{[A^-]}{[HA]}$$

$$\text{p}K_a = -\log K_a, \text{ p}K_b = -\log K_b$$

Equilibrium Constants

 K_c (molar concentrations) K_p (gas pressures) K_a (weak acid) K_b (weak base) K_w (water)

KINETICS

$$\ln[A]_t - \ln[A]_0 = -kt$$

$$\frac{1}{[A]_t} - \frac{1}{[A]_0} = kt$$

$$t_{1/2} = \frac{0.693}{k}$$

 k = rate constant t = time $t_{1/2}$ = half-life

GO ON TO THE NEXT PAGE.

GASES, LIQUIDS, AND SOLUTIONS

$$PV = nRT$$

$$P_A = P_{\text{total}} \times X_A, \text{ where } X_A = \frac{\text{moles A}}{\text{total moles}}$$

$$P_{\text{total}} = P_A + P_B + P_C + \dots$$

$$n = \frac{m}{M}$$

$$K = ^\circ\text{C} + 273$$

$$D = \frac{m}{V}$$

$$KE \text{ per molecule} = \frac{1}{2}mv^2$$

Molarity, M = moles of solute per liter of solution

$$A = abc$$

P = pressure

V = volume

T = temperature

n = number of moles

m = mass

M = molar mass

D = density

KE = kinetic energy

v = velocity

A = absorbance

a = molar absorptivity

b = path length

c = concentration

Gas constant, $R = 8.314 \text{ J mol}^{-1} \text{ K}^{-1}$

$$= 0.08206 \text{ L atm mol}^{-1} \text{ K}^{-1}$$

$$= 62.36 \text{ L torr mol}^{-1} \text{ K}^{-1}$$

$$1 \text{ atm} = 760 \text{ mm Hg}$$

$$= 760 \text{ torr}$$

STP = 273.15 K and 1.0 atm

Ideal gas at STP = 22.4 L mol⁻¹

THERMOCHEMISTRY/ ELECTROCHEMISTRY

$$q = mc\Delta T$$

$$\Delta S^\circ = \sum S^\circ \text{ products} - \sum S^\circ \text{ reactants}$$

$$\Delta H^\circ = \sum \Delta H_f^\circ \text{ products} - \sum \Delta H_f^\circ \text{ reactants}$$

$$\Delta G^\circ = \sum \Delta G_f^\circ \text{ products} - \sum \Delta G_f^\circ \text{ reactants}$$

$$\Delta G^\circ = \Delta H^\circ - T\Delta S^\circ$$

$$= -RT \ln K$$

$$= -nFE^\circ$$

$$I = \frac{q}{t}$$

q = heat

m = mass

c = specific heat capacity

T = temperature

S° = standard entropy

H° = standard enthalpy

G° = standard free energy

n = number of moles

E° = standard reduction potential

I = current (amperes)

q = charge (coulombs)

t = time (seconds)

Faraday's constant, $F = 96,485$ coulombs per mole of electrons

$$1 \text{ volt} = \frac{1 \text{ joule}}{1 \text{ coulomb}}$$

GO ON TO THE NEXT PAGE.

- In a saturated solution of Na_3PO_4 , $[\text{Na}^+] = 0.30 \text{ M}$. What is the molar solubility of Na_3PO_4 ?
 - 0.10 M
 - 0.30 M
 - 0.60 M
 - 0.90 M
- When some LiCl is dissolved in water, the temperature of the water increases. This means that:
 - the strength of the intermolecular forces between the water molecules is stronger than the bond energy within the LiCl lattice
 - the attraction of the lithium ions to the negative dipoles of the water molecules is weaker than the attraction of the chloride ions to the positive dipoles of the water molecules
 - breaking the bonds between the lithium and chloride ions is an exothermic process
 - the strength of the ion-dipole attractions that are formed exceeds the lattice energy in LiCl
- What is the approximate $\text{p}K_b$ for methylamine?
 - 3.5
 - 5.5
 - 10.5
 - 12.5
- The buffer region of this titration is located:
 - Below 3.0 mL
 - Between 3.0 mL and 14.0 mL
 - Between 14.0 mL and 16.0 mL
 - Above 16.0 mL
- The methylamine is replaced by 20.0 mL of sodium hydroxide of an identical concentration. If the sodium hydroxide is titrated with the 1.0 M HCl , which of the following options accurately describes the pH levels at various points during the titration when compared to the pH levels at the same point in the HCl /methylamine titration?

	Initial pH	Equivalence pH	Ending pH
(A)	lower	same	higher
(B)	higher	higher	same
(C)	same	higher	same
(D)	higher	lower	lower

Use the following information to answer questions 3-6

A student titrates some 1.0 M HCl into 20.0 mL of methylamine (CH_3NH_2), a weak base which only accepts a single proton. The following titration curve results:

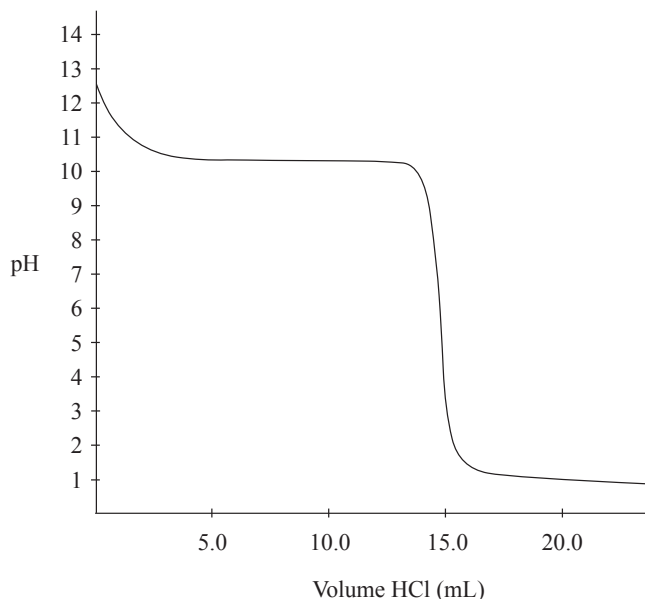

- What is the concentration of the methylamine?
 - 0.50 M
 - 0.75 M
 - 1.0 M
 - 1.25 M

- The formate ion, HCO_2^- , is best represented by the Lewis diagram below. Each bond is labeled with a different letter.

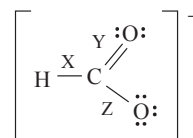

What is the bond order for each bond?

	X	Y	Z
(A)	1	1	2
(B)	2	2	1
(C)	1	1.5	1.5
(D)	1.33	1.33	1.33

GO ON TO THE NEXT PAGE.

Section I

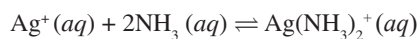

8. The reaction above is at equilibrium in a closed system. Which of the following will happen immediately when water is added?
- (A) The rate of the reverse reaction will increase.
 (B) Both ions will increase in concentration, while the NH_3 decreases in concentration.
 (C) The reaction will shift to the right.
 (D) Nothing will happen; adding water does not cause any changes to the equilibrium system.



9. The two products above are created from a reaction involving CO and NO_2 . Which of the following options indicates a viable orientation of both reactant molecules prior to the collision? (Note: the arrows indicate the direction each molecule is moving prior to the collision.)

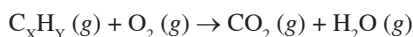
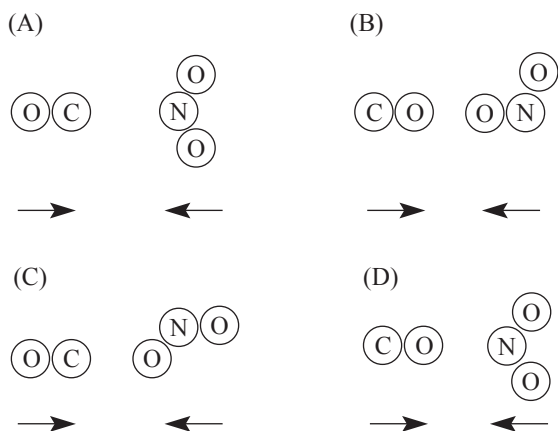

10. When the above unbalanced reaction occurs at STP, 1.5 L of CO_2 and 1.0 L of H_2O are created. What is the empirical formula of the hydrocarbon?
- (A) CH_2
 (B) C_2H_3
 (C) C_2H_5
 (D) C_3H_4



11. For the decomposition of hydrogen peroxide, which element (if any) is being reduced, and which is being oxidized?

	Oxidized	Reduced
(A)	Hydrogen	Oxygen
(B)	Oxygen	None
(C)	None	Hydrogen
(D)	Oxygen	Oxygen

12. Identical amounts of the four gases listed below are present in four separate balloons. At STP, which balloon size experiences the greatest deviation from the volume calculated using the Ideal Gas Law?

- (A) H_2
 (B) O_2
 (C) N_2
 (D) F_2

13. Which of the following reasons correctly explains one reason that increasing the temperature of a reaction increases its speed?

- (A) All reactant molecules will have more kinetic energy.
 (B) A larger percentage of reactant molecules will exceed the activation energy barrier.
 (C) A higher percentage of molecular collisions will have the correct orientation to cause a reaction.
 (D) The order of each reactant will increase.

GO ON TO THE NEXT PAGE.

Use the following information to answer questions 14-16

The radius of atoms and ions is typically measured in Angstroms (Å), which is equivalent to 1×10^{-10} m. Below is a table of information for three different elements.

Element	Atomic Radius (Å)	Ionic Radius (Å)
Ne	0.38	N/A
P	0.98	1.00
Zn	1.42	1.35

14. The phosphorus ion is larger than a neutral phosphorus atom, yet a zinc ion is smaller than a neutral zinc atom. Which of the following statements best explains why?
- (A) The zinc atom has more protons than the phosphorus atom.
 (B) The phosphorus atom has fewer valence electrons than the zinc atom.
 (C) Phosphorus gains electrons when forming an ion, but zinc loses them.
 (D) The valence electrons in zinc are further from the nucleus than those in phosphorus.
15. Neon has a smaller atomic radius than phosphorus because:
- (A) Unlike neon, phosphorus has electrons present in its third energy level.
 (B) Phosphorus has more protons than neon, which increases the repulsive forces in the atom.
 (C) The electrons in a neon atom are all found in a single energy level.
 (D) Phosphorus can form anions, while neon is unable to form any ions.
16. Which of the following represents the correct electron configuration for the zinc ion, Zn^{2+} ?
- (A) $[Ar]3d^{10}$
 (B) $[Ar]4s^23d^8$
 (C) $[Ar]4s^24d^8$
 (D) $[Kr]4s^23d^8$

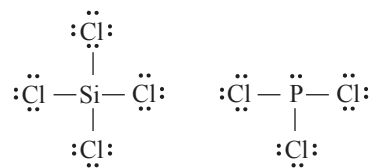

17. The Lewis diagrams for SiCl_4 and PCl_3 are drawn above. What are the approximate bond angles between the terminal chlorine atoms in each structure?

	SiCl_4	PCl_3
(A)	90	90
(B)	109.5°	$< 109.5^\circ$
(C)	90°	109.5°
(D)	$< 109.5^\circ$	$> 90^\circ$

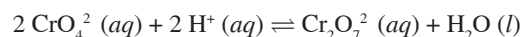

18. The above reaction is present at equilibrium in a beaker. A student stirs the mixture. What effect will this have on the reaction rates?
- (A) It will increase both the forward and reverse reaction rates.
 (B) It will increase the forward rate, but decrease the reverse rate.
 (C) It will have no effect on the forward rate, but it will decrease the reverse rate.
 (D) It will have no effect on either rate.
19. A sample of water originally at 25°C is heated to 75°C . As the temperature increases, the vapor pressure of the water is also observed to increase. Why?
- (A) Water molecules are more likely to have enough energy to break free of the intermolecular forces holding them together.
 (B) The covalent bonds between the hydrogen and oxygen atoms within individual water molecules are more likely to be broken.
 (C) The strength of the hydrogen bonding between different water molecules will increase until it exceeds the covalent bond energy within individual water molecules.
 (D) The electron clouds surrounding each water molecule are becoming less polarizable, weakening the intermolecular forces between them.

GO ON TO THE NEXT PAGE.

Section I

20. The enthalpy change for which of the following reactions would be equal to the enthalpy of formation for ethanol ($\text{CH}_3\text{CH}_2\text{OH}$)?
- (A) $\text{CH}_3 + \text{CH}_2 + \text{OH} \rightarrow \text{CH}_3\text{CH}_2\text{OH}$
 (B) $2\text{C} + 5\text{H} + \text{O} \rightarrow \text{CH}_3\text{CH}_2\text{OH}$
 (C) $4\text{C} + 6\text{H}_2 + \text{O}_2 \rightarrow 2\text{CH}_3\text{CH}_2\text{OH}$
 (D) $2\text{C} + 3\text{H}_2 + \frac{1}{2}\text{O}_2 \rightarrow \text{CH}_3\text{CH}_2\text{OH}$
21. A chemist wants to plate out 1.00 g of solid iron from a solution containing aqueous Fe^{2+} ions. Which of the following expressions will equal the amount of time, in seconds, it takes if a current of 5.00 A is applied?
- (A) $\frac{(2)(55.85)(5.00)}{96500}$
 (B) $\frac{(2)(96500)}{(55.85)(5.00)}$
 (C) $\frac{(55.85)(96500)}{(2)(5.00)}$
 (D) $\frac{(2)(55.85)(96500)}{(5.00)}$

Use the following information to answer questions 22-24

10.0 g each of three different gases are present in three glass containers of identical volume, as shown below. The temperature of all three flasks is held constant at 298 K.



22. The container with which gas would have the greatest pressure?
- (A) SO_2
 (B) CH_4
 (C) NCl_3
 (D) All four containers would have the same pressure.
23. Which of the gases would have the greatest density?
- (A) SO_2
 (B) CH_4
 (C) NCl_3
 (D) All three gases would have the same density.
24. If a small, pinhole-size leak were to be drilled into each container, the container with which gas would experience the fastest pressure decrease?
- (A) SO_2
 (B) CH_4
 (C) NCl_3
 (D) All three containers would decrease pressure at the same rate.
-
- $\text{CO}_2(g) + \text{H}_2(g) \rightleftharpoons \text{CO}(g) + \text{H}_2\text{O}(g) \quad K_c = 1.4$
 $\text{CO}(g) + 2\text{H}_2(g) \rightleftharpoons \text{CH}_3\text{OH}(g) \quad K_c = 14.5$
25. Given the above information, what would the equilibrium constant for the below reaction be?
- $3\text{CO}(g) + 2\text{H}_2\text{O}(g) \rightleftharpoons 2\text{CO}_2(g) + \text{CH}_3\text{OH}(g)$
- (A) $(2)(1.4)(14.5)$
 (B) $\frac{(1.4)(14.5)}{2}$
 (C) $\frac{14.5}{(1.4)^2}$
 (D) $14.5 - 1.4^2$
- $2\text{H}_2(g) + \text{O}_2(g) \rightarrow 2\text{H}_2\text{O}(g)$
26. When 1.0 mole of H_2 is combined with 1.0 mol of O_2 in a sealed flask, the reaction above occurs to completion at a constant temperature. After the reaction, the pressure in the container will have:
- (A) Increased by 25%
 (B) Increased by 50%
 (C) Decreased by 25%
 (D) Decreased by 50%
27. A strong acid/strong base titration is completed using an indicator which changes color at the exact equivalence point of the titration. The protonated form of the indicator is HIn , and the deprotonated form is In^- . At the equivalence point of the reaction:
- (A) $[\text{HIn}] = [\text{In}^-]$
 (B) $[\text{HIn}] = 1/[\text{In}^-]$
 (C) $[\text{HIn}] = 2[\text{In}^-]$
 (D) $[\text{HIn}] = [\text{In}^-]^2$

GO ON TO THE NEXT PAGE.

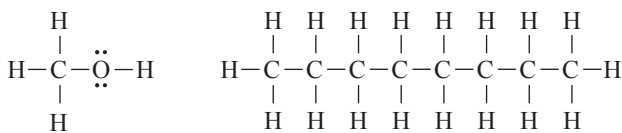

Ethanol

Octane

28. The Lewis diagrams for both ethanol and octane are drawn above. Ethanol's boiling point is 78°C , while octane's is 125°C . This is best explained by the fact that:
- (A) Octane has hydrogen bonding, while ethanol does not.
- (B) Octane has a significantly higher molar mass than ethanol.
- (C) Octane's temporary dipoles are stronger than those in ethanol.
- (D) Octane is more symmetrical than ethanol.
29. Which compound, CaCl_2 or CaO , would you expect to have a high melting point? Why?
- (A) CaCl_2 , because there are more ions per lattice unit
- (B) CaCl_2 , because a chlorine ion is smaller than an oxygen ion
- (C) CaO , because the charge of oxygen ion exceeds that of chlorine ion
- (D) CaO , because the common charges of calcium and oxygen ions are identical in magnitude
30. Even though it is a noble gas, xenon is known to form bonds with other elements. Which element from the options below would xenon most likely be able to bond with?
- (A) Lithium
- (B) Argon
- (C) Fluorine
- (D) Carbon
31. Stock nitric acid, HNO_3 , has a concentration of 15.8 M . The pH of stock nitric acid would fall into which of the following pH ranges?
- (A) Between -2 and -1
- (B) Between -1 and 0
- (C) Between 0 and 1
- (D) Between 1 and 2
32. During gravimetric analysis experiments, collected precipitates are often rinsed with distilled water prior to being collected. What is the purpose of doing so?
- (A) This ensures the precipitation reaction has gone to completion
- (B) It washes away any spectator ions stuck to the precipitate
- (C) The precipitate must be fully hydrated
- (D) Washing the precipitate ensures it has the correct density



33. The above equilibrium is established in a sealed container. Some neon gas is injected into the container at constant temperature. If the neon does not react with any of the species in the container, what effect will this have on the reaction quotient and the reaction rates for this reaction?
- (A) Q will increase, causing the forward reaction rate to increase
- (B) Q will increase, causing the reverse reaction rate to increase
- (C) Q will decrease, causing the forward reaction rate to decrease
- (D) Q will remain unchanged and the reaction rates will also remain unchanged

GO ON TO THE NEXT PAGE.

Use the following information to answer question 34–38.

A 10.0 g sample of NaNO_3 is dissolved in 200.0 mL of water with stirring, and the temperature of the water changes from 23.0°C to 18.0°C during the process. Assume the density and the specific heat of the final solution are identical to those of water.

34. Which of the following diagrams correctly shows a particulate representation of the species present in the beaker after the NaNO_3 has dissolved?

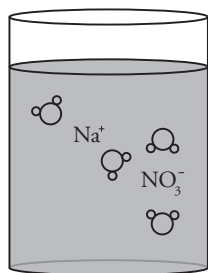

(A)

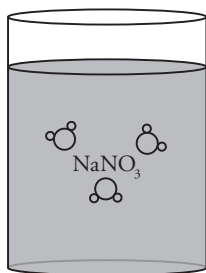

(C)

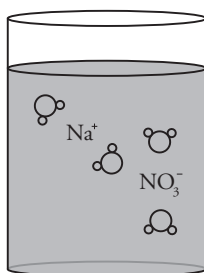

(B)

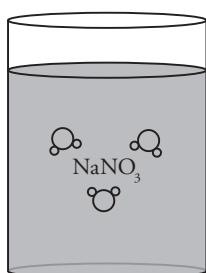

(D)

35. Which of the following statements best describes the enthalpy of solution for NaNO_3 ?
- It will be greater than zero because energy is absorbed from the water
 - It will be greater than zero because the magnitude of the ion-dipole attractive forces exceed the lattice energy of NaNO_3
 - It will be less than zero because water is a highly polar solvent
 - It will be less than zero due to the presence of the polyatomic NO_3^- anion

36. During the process, energy is released when:
- The ionic bonds within the NaNO_3 lattice are broken
 - The water molecules are spread apart to make room for the dissolved NaNO_3
 - New attractive forces form between the dissociated ions and the water dipoles
 - The covalent bonds within the water molecules are broken
37. Which of the following expressions will correctly calculate the heat change experienced by the water?
- $(200.0 \text{ g})(4.18 \text{ J/g}^\circ\text{C})(-5.0^\circ\text{C})$
 - $(210.0 \text{ g})(4.18 \text{ J/g}^\circ\text{C})(-5.0^\circ\text{C})$
 - $(10.0 \text{ g})(4.18 \text{ J/g}^\circ\text{C})(-5.0^\circ\text{C})$
 - $(200.0 \text{ g})(4.18 \text{ J/g}^\circ\text{C})(5.0^\circ\text{C})$
38. After experimentally determining the enthalpy of solution for NaNO_3 using the gathered data, the magnitude of the experimental value is found to be lower than the accepted value. Which of the following correctly identifies a reason why?
- Some water evaporated while the NaNO_3 was dissolving
 - The specific heat of the final solution is actually lower than $4.18 \text{ J/g}^\circ\text{C}$
 - The stirring of the solution added significant energy to the system
 - Some energy from the dissolution process was lost to the surroundings

39. Red light has a wavelength of 680 nm, and blue light has a wavelength of 470 nm. Which of the following options correctly identifies the relationships between the frequencies and energy levels of red and blue light?

	Frequency	Energy
(A)	Red > Blue	Red > Blue
(B)	Red > Blue	Red < Blue
(C)	Red < Blue	Red > Blue
(D)	Red < Blue	Red < Blue

GO ON TO THE NEXT PAGE.

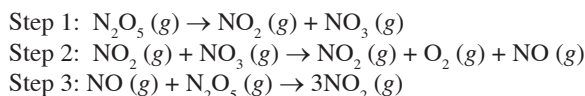

40. The rate law for the above reaction is determined to be $\text{rate} = k[\text{N}_2\text{O}_5]$. Which of the following options correctly identifies the overall order of the reaction as well as the molecularity of the rate-determining step?
- (A) First order, unimolecular
 (B) Second order, bimolecular
 (C) Third order, bimolecular
 (D) Fifth order, unimolecular
41. As temperature decreases, the pH of water increases. This means that:
- (A) The number of H^+ and OH^- ions are increasing
 (B) Water is more basic at lower temperatures
 (C) $[\text{H}^+]$ begins to exceed the $[\text{OH}^-]$
 (D) The auto-ionization of water is an endothermic process

42. The Lewis diagrams for four different compounds are drawn below. In which molecule would the dipole moment be closest to zero?

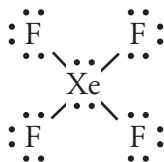

(A)

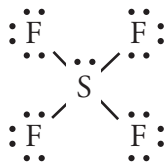

(C)

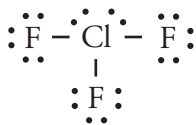

(B)

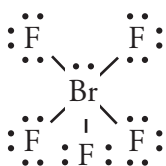

(D)

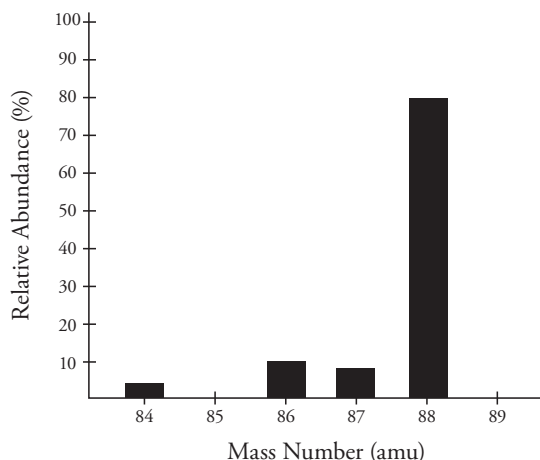

43. The mass spectrum above shows the distribution of various isotopes of strontium. Based on the data, which of the following conclusions can be drawn?
- (A) Strontium most commonly forms ions with a charge of +2
 (B) Strontium isotopes with a mass of 86 or 87 are very unstable
 (C) The number of protons in a strontium atom nucleus can vary
 (D) The most common isotope of strontium has 50 neutrons

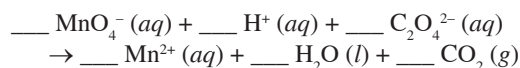

44. When the above oxidation-reduction reaction is completely balanced, what is the coefficient on the MnO_4^- ion?
- (A) 1
 (B) 2
 (C) 3
 (D) 4

GO ON TO THE NEXT PAGE.

Use the following information to answer questions 45-47

Zinc iodate dissociates in water via the following equilibrium process:

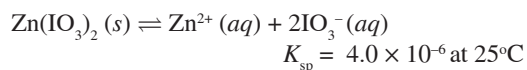

45. What is the approximate molar solubility of zinc iodate at 25°C ?
- (A) $1.0 \times 10^{-2} M$
 (B) $2.0 \times 10^{-3} M$
 (C) $4.0 \times 10^{-6} M$
 (D) $1.0 \times 10^{-6} M$
46. Which of the following solutions would zinc iodate be the LEAST soluble in?
- (A) 1.0 M BaCl_2
 (B) 1.0 M NaIO_3
 (C) 1.0 M K_2CO_3
 (D) Pure water
47. A beaker of saturated zinc iodate is left out overnight. The following morning, some water is found to have evaporated. Assuming the temperature remained constant at 25°C , which of the following options correctly identifies the changes in the $[\text{Zn}^{2+}]$ and the mass of the zinc iodate present in the beaker compared to the previous night?

	$[\text{Zn}^{2+}]$	Mass $\text{Zn}(\text{IO}_3)_2$
(A)	Increase	Decrease
(B)	Increase	No Change
(C)	No Change	Increase
(D)	No Change	Decrease

48. Which of the following reactions would be favored at lower temperatures, but not favored at higher temperatures?
- (A) $2\text{Fe}_2\text{O}_3(s) + 3\text{C}(s) \rightarrow 4\text{Fe}(s) + 3\text{CO}_2(g)$
 $\Delta H^\circ = +468 \text{ kJ/mol}_{\text{rxn}}$
- (B) $\text{S}(g) + \frac{1}{2}\text{O}_2(g) \rightarrow \text{SO}_2(g)$
 $\Delta H^\circ = -297 \text{ kJ/mol}_{\text{rxn}}$
- (C) $\text{N}_2\text{H}_4(l) + \text{CH}_2\text{O}(l) \rightarrow \text{CH}_2\text{O}(g) + \text{N}_2(g) + 3\text{H}_2(g)$
 $\Delta H^\circ = -37 \text{ kJ/mol}_{\text{rxn}}$
- (D) $2\text{B}(s) + 3\text{H}_2(g) \rightarrow \text{B}_2\text{H}_6(g)$
 $\Delta H^\circ = +36 \text{ kJ/mol}_{\text{rxn}}$
49. Which of the following statements regarding covalent bonds is true?
- (A) Two atoms will form a covalent bond at the distance which minimizes the potential energy between them
- (B) Covalent bonds always involve the equal sharing of valence electrons between two atoms
- (C) The breaking of a covalent bond always occurs during a liquid to gas phase change for a covalent substance
- (D) Covalent bonds typically form between atoms that demonstrate metallic properties

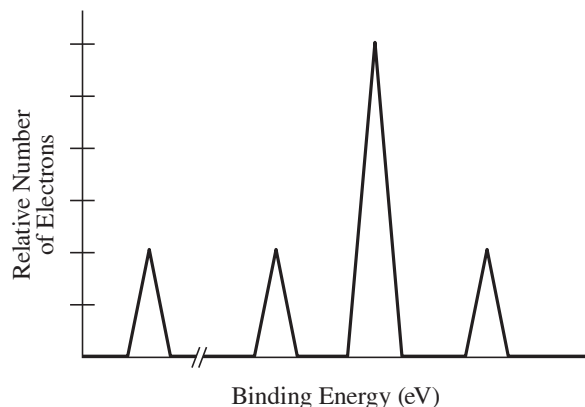

50. The photoelectron spectrum of an element is above. Based on the spectrum, what is the charge on the most common ion of the element?
- (A) -2
 (B) -1
 (C) +1
 (D) +2

GO ON TO THE NEXT PAGE.

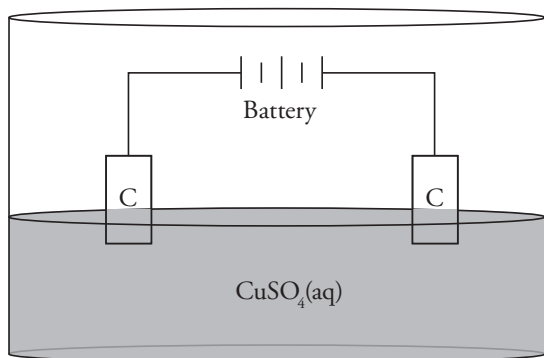

51. A beaker is filled with some 1.0 M CuSO_4 , and two carbon electrodes are placed in the beaker with a battery wired between them, as shown above. As current is run through the system, solid copper plates out onto the carbon cathode. Which of the following changes would increase the amount of solid copper that is plated out of solution?
- (A) Replacing the 1.0 M CuSO_4 solution with 1.0 M CuCl_2
 (B) Using a 9.0 V battery instead of a 1.5 V battery
 (C) Decreasing the pH of the solution
 (D) Changing out the carbon electrodes with platinum electrodes



52. 1.0 mole of $\text{NO}_2(g)$ is bubbled through excess water, causing the above reaction to take place. Which of the following statements correctly describes the energy change that will occur during the reaction?
- (A) 135 kJ of energy will be emitted
 (B) 45 kJ of energy will be emitted
 (C) 135 kJ of energy will be absorbed
 (D) 405 kJ of energy will be absorbed

Bond	Energy (kJ/mol)
C-H	413
O=O	498
O-H	467

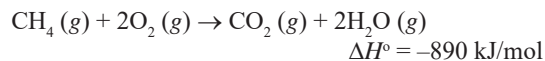

53. Determine the approximate bond energy of a C=O bond given the above data.
- (A) 400 kJ/mol
 (B) 600 kJ/mol
 (C) 800 kJ/mol
 (D) 1000 kJ/mol

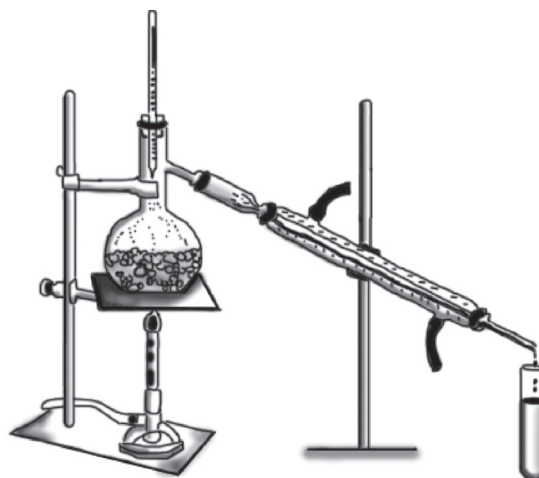

Substance	Vapor Pressure @ 25°C (torr)
H_2O	23.8
CH_3OH	99.0
C_6H_{12}	78.0

54. Three different liquids are mixed together in a flask, and that flask is then hooked up to a distillation apparatus, as shown above. The liquids are initially at 25°C, and the heat is turned up until the mixture starts to boil. Which liquid would be the first to separate out of the mixture?
- (A) H_2O
 (B) CH_3OH
 (C) C_6H_{12}
 (D) Distillation would be an ineffective method of separating the mixture

GO ON TO THE NEXT PAGE.

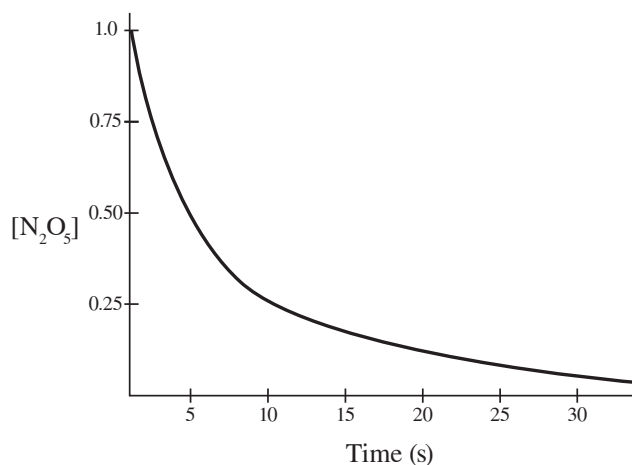

55. A sample of some N_2O_5 gas is placed in a sealed container and allowed to decompose. The concentration of the N_2O_5 is tracked over time, and the results are plotted on the above graph. Which of the following represent the possible units on the rate constant for this reaction?

- (A) s^{-1}
 (B) sM^{-1}
 (C) Ms^{-1}
 (D) Ms^{-2}

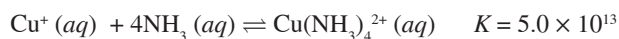

56. The above system is at equilibrium. If it were to be diluted, what would happen to the moles of reactants and the moles product after equilibrium is reestablished?

	Mole Reactants	Moles Product
(A)	Increase	Increase
(B)	Increase	Decrease
(C)	Decrease	Decrease
(D)	No Change	No Change

Use the following information to answer questions 57-60

A beaker contains 100. mL of a 1.0 M solution of benzoic acid, $\text{C}_6\text{H}_5\text{COOH}$, which has a pK_a value of 4.19. 50. mL of Solution X is added to the beaker, creating a buffer with a pH of 4.19.

57. Which of the following could be the identity of the Solution X?
- (A) 1.0 M NaOH
 (B) 1.0 M HCl
 (C) 1.0 M NaCl
 (D) 1.0 M NH_3
58. If the buffer solution was then diluted with 150. mL of distilled water, which of the following values would be closest to the pH of the diluted buffer solution?
- (A) 2.08
 (B) 4.19
 (C) 5.19
 (D) 6.27

GO ON TO THE NEXT PAGE.

59. In the diagrams below, benzoic acid is represented by HA, and the benzoate ion, $C_6H_5COO^-$, is represented by A^- . Which of the beakers shows the correct ratio of HA: A^- in a buffer solution that has a pH of 3.19?

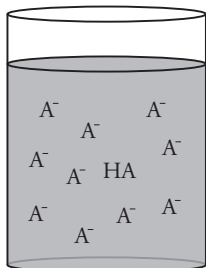

(A)

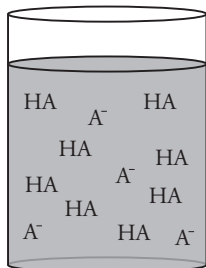

(C)

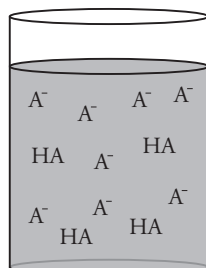

(B)

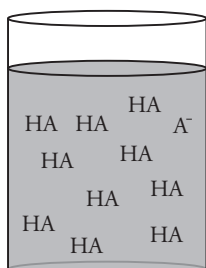

(D)

60. The benzoic acid solution can be made into an effective buffer. Which of the following statements best explain why a HCl solution of identical concentration NOT be part of a buffer?

- (A) The K_a value for benzoic acid is greater than the K_a value for HCl
- (B) HCl has stronger intermolecular forces than C_6H_5COOH
- (C) The Cl^- ion is a less effective conjugate base than $C_6H_5COO^-$
- (D) HCl has far few protons in it than C_6H_5COOH

END OF SECTION I

INFORMATION IN THE TABLE BELOW AND ON THE FOLLOWING PAGES MAY BE USEFUL IN ANSWERING THE QUESTIONS IN THIS SECTION OF THE EXAMINATION.

DO NOT DETACH FROM BOOK.

PERIODIC TABLE OF THE ELEMENTS

1	2																	3	4	5	6	7	8	9	10
H 1.008	He 4.00																	Li 6.94	Be 9.01	B 10.81	C 12.01	N 14.01	O 16.00	F 19.00	Ne 20.18
3	4																	5	6	7	8	9	10		
Li 6.94	Be 9.01																	B 10.81	C 12.01	N 14.01	O 16.00	F 19.00	Ne 20.18		
11	12																	13	14	15	16	17	18		
Na 22.99	Mg 24.30																	Al 26.98	Si 28.09	P 30.97	S 32.06	Cl 35.45	Ar 39.95		
19	20	21	22	23	24	25	26	27	28	29	30	31	32	33	34	35	36								
K 39.10	Ca 40.08	Sc 44.96	Ti 47.90	V 50.94	Cr 52.00	Mn 54.94	Fe 55.85	Co 58.93	Ni 58.69	Cu 63.55	Zn 65.39	Ga 69.72	Ge 72.59	As 74.92	Se 78.96	Br 79.90	Kr 83.80								
37	38	39	40	41	42	43	44	45	46	47	48	49	50	51	52	53	54								
Rb 85.47	Sr 87.62	Y 88.91	Zr 91.22	Nb 92.91	Mo 95.94	Tc (98)	Ru 101.1	Rh 102.91	Pd 106.42	Ag 107.87	Cd 112.41	In 114.82	Sn 118.71	Sb 121.75	Te 127.60	I 126.91	Xe 131.29								
55	56	57	72	73	74	75	76	77	78	79	80	81	82	83	84	85	86								
Cs 132.91	Ba 137.33	*La 138.91	Hf 178.49	Ta 180.95	W 183.85	Re 186.21	Os 190.2	Ir 192.2	Pt 195.08	Au 196.97	Hg 200.59	Tl 204.38	Pb 207.2	Bi 208.98	Po (209)	At (210)	Rn (222)								
87	88	89	104	105	106	107	108	109	110	111															
Fr (223)	Ra 226.02	†Ac 227.03	Rf (261)	Db (262)	Sg (266)	Bh (264)	Hs (277)	Mt (268)	Ds (271)	Rg (272)															
*Lanthanide Series																									
58	59	60	61	62	63	64	65	66	67	68	69	70	71												
Ce 140.12	Pr 140.91	Nd 144.24	Pm (145)	Sm 150.4	Eu 151.97	Gd 157.25	Tb 158.93	Dy 162.50	Ho 164.93	Er 167.26	Tm 168.93	Yb 173.04	Lu 174.97												
†Actinide Series																									
90	91	92	93	94	95	96	97	98	99	100	101	102	103												
Th 232.04	Pa 231.04	U 238.03	Np (237)	Pu (244)	Am (243)	Cm (247)	Bk (247)	Cf (251)	Es (252)	Fm (257)	Md (258)	No (259)	Lr (262)												

GO ON TO THE NEXT PAGE.

ADVANCED PLACEMENT CHEMISTRY EQUATIONS AND CONSTANTS

Throughout the test the following symbols have the definitions specified unless otherwise noted.

L, mL = liter(s), milliliter(s)
 g = gram(s)
 nm = nanometer(s)
 atm = atmosphere(s)

mm Hg = millimeters of mercury
 J, kJ = joule(s), kilojoule(s)
 V = volt(s)
 mol = mole(s)

ATOMIC STRUCTURE

$$E = h\nu$$

$$c = \lambda\nu$$

E = energy
 ν = frequency
 λ = wavelength

Planck's constant, $h = 6.626 \times 10^{-34}$ J s

Speed of light, $c = 2.998 \times 10^8$ m s⁻¹

Avogadro's number = 6.022×10^{23} mol⁻¹

Electron charge, $e = -1.602 \times 10^{-19}$ coulomb

EQUILIBRIUM

$$K_c = \frac{[C]^c [D]^d}{[A]^a [B]^b}, \text{ where } a A + b B \rightleftharpoons c C + d D$$

$$K_p = \frac{(P_C)^c (P_D)^d}{(P_A)^a (P_B)^b}$$

$$K_a = \frac{[H^+][A^-]}{[HA]}$$

$$K_b = \frac{[OH^-][HB^+]}{[B]}$$

$$K_w = [H^+][OH^-] = 1.0 \times 10^{-14} \text{ at } 25^\circ\text{C}$$

$$= K_a \times K_b$$

$$\text{pH} = -\log[H^+], \text{ pOH} = -\log[OH^-]$$

$$14 = \text{pH} + \text{pOH}$$

$$\text{pH} = \text{p}K_a + \log \frac{[A^-]}{[HA]}$$

$$\text{p}K_a = -\log K_a, \text{ p}K_b = -\log K_b$$

Equilibrium Constants

K_c (molar concentrations)

K_p (gas pressures)

K_a (weak acid)

K_b (weak base)

K_w (water)

KINETICS

$$\ln[A]_t - \ln[A]_0 = -kt$$

$$\frac{1}{[A]_t} - \frac{1}{[A]_0} = kt$$

$$t_{1/2} = \frac{0.693}{k}$$

k = rate constant

t = time

$t_{1/2}$ = half-life

GO ON TO THE NEXT PAGE.

GASES, LIQUIDS, AND SOLUTIONS

$$PV = nRT$$

$$P_A = P_{\text{total}} \times X_A, \text{ where } X_A = \frac{\text{moles A}}{\text{total moles}}$$

$$P_{\text{total}} = P_A + P_B + P_C + \dots$$

$$n = \frac{m}{M}$$

$$K = ^\circ\text{C} + 273$$

$$D = \frac{m}{V}$$

$$KE \text{ per molecule} = \frac{1}{2}mv^2$$

Molarity, M = moles of solute per liter of solution

$$A = abc$$

P = pressure

V = volume

T = temperature

n = number of moles

m = mass

M = molar mass

D = density

KE = kinetic energy

v = velocity

A = absorbance

a = molar absorptivity

b = path length

c = concentration

Gas constant, $R = 8.314 \text{ J mol}^{-1} \text{ K}^{-1}$

$$= 0.08206 \text{ L atm mol}^{-1} \text{ K}^{-1}$$

$$= 62.36 \text{ L torr mol}^{-1} \text{ K}^{-1}$$

$$1 \text{ atm} = 760 \text{ mm Hg}$$

$$= 760 \text{ torr}$$

STP = 273.15 K and 1.0 atm

Ideal gas at STP = 22.4 L mol⁻¹

THERMOCHEMISTRY/ ELECTROCHEMISTRY

$$q = mc\Delta T$$

$$\Delta S^\circ = \sum S^\circ \text{ products} - \sum S^\circ \text{ reactants}$$

$$\Delta H^\circ = \sum \Delta H_f^\circ \text{ products} - \sum \Delta H_f^\circ \text{ reactants}$$

$$\Delta G^\circ = \sum \Delta G_f^\circ \text{ products} - \sum \Delta G_f^\circ \text{ reactants}$$

$$\Delta G^\circ = \Delta H^\circ - T\Delta S^\circ$$

$$= -RT \ln K$$

$$= -nFE^\circ$$

$$I = \frac{q}{t}$$

q = heat

m = mass

c = specific heat capacity

T = temperature

S° = standard entropy

H° = standard enthalpy

G° = standard free energy

n = number of moles

E° = standard reduction potential

I = current (amperes)

q = charge (coulombs)

t = time (seconds)

Faraday's constant, $F = 96,485$ coulombs per mole of electrons

$$1 \text{ volt} = \frac{1 \text{ joule}}{1 \text{ coulomb}}$$

GO ON TO THE NEXT PAGE.

CHEMISTRY

Section II

7 Questions

(Total time—105 minutes)

YOU MAY USE YOUR CALCULATOR FOR THIS SECTION

Directions: Questions 1-3 are long free-response questions that require about 23 minutes each to answer and are worth 10 points each. Questions 4-7 are short free-response questions that require about 9 minutes each to answer and are worth 4 points each.

Write your response in the space provided following each question. Examples and equations may be included in your responses where appropriate. For calculations, clearly show the method used and the steps involved in arriving at your answers. You must show your work to receive credit for your answer. Pay attention to significant figures.

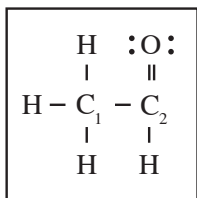
Acetaldehyde, CH_3COH

BP = 293K

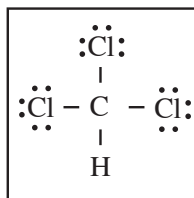
Chloroform, CHCl_3

BP = 334K

Methanoic acid, HCOOH

BP = 374K

1. The boiling points of three different compounds are listed above, along with their formulas.
 - (a) In the blank box above, draw the Lewis diagram for methanoic acid. There are two carbon-oxygen bonds present, one of which is shorter than the other.
 - (b)
 - (i) What is the hybridization around atom C_2 in the acetaldehyde molecule?
 - (ii) Chloroform is known to be polar. Draw the location of any positive and negative dipoles on a chloroform molecule.
 - (c) Which of the three molecules would have the greatest degree of polarizability? Justify your answer.

GO ON TO THE NEXT PAGE.

Section II

Equal amounts of all three liquids are mixed together inside a beaker.

- (d) A sample of the mixture is placed on a piece of chromatography paper, and the bottom of the paper is immersed in water. After some time passes, the mixture separates. The location of two components of the mixture are charted on the diagram below.

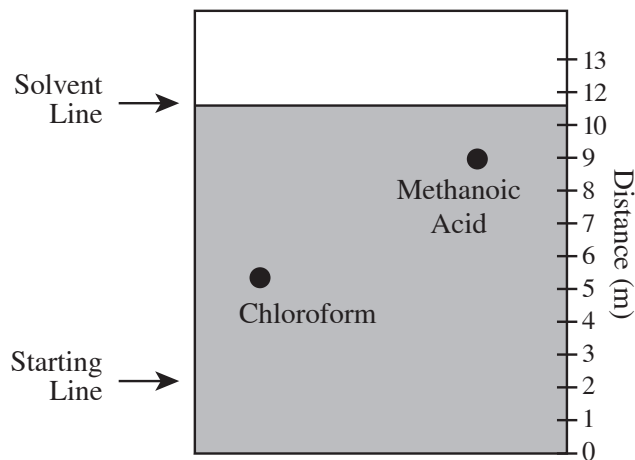

- (i) What is the R_f value for the methanoic acid?
(ii) On the diagram above draw and label a dot that would be a reasonable estimate of the distance the acetaldehyde would travel.

The beaker containing the mixture is then attached to a distillation apparatus and heated, as shown below.

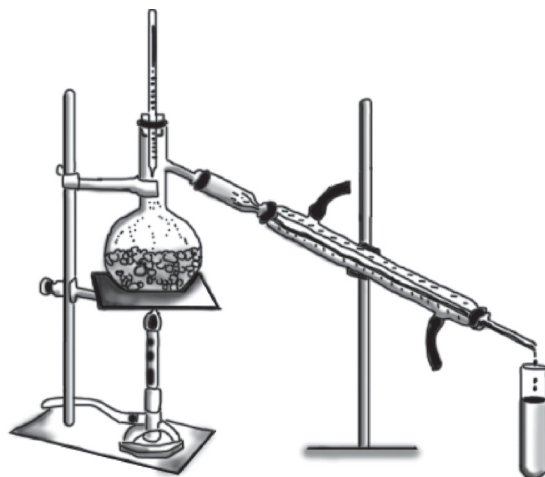

- (e) (i) If the temperature of the beaker is gradually raised, which substance will separate out first? Justify your answer.
(ii) Which of the following temperatures would be the best option in order to create the purest distillate possible? Justify your answer.

210 K

300 K

330 K

390 K

GO ON TO THE NEXT PAGE.

2. A galvanic cell is set up according to the following diagram.

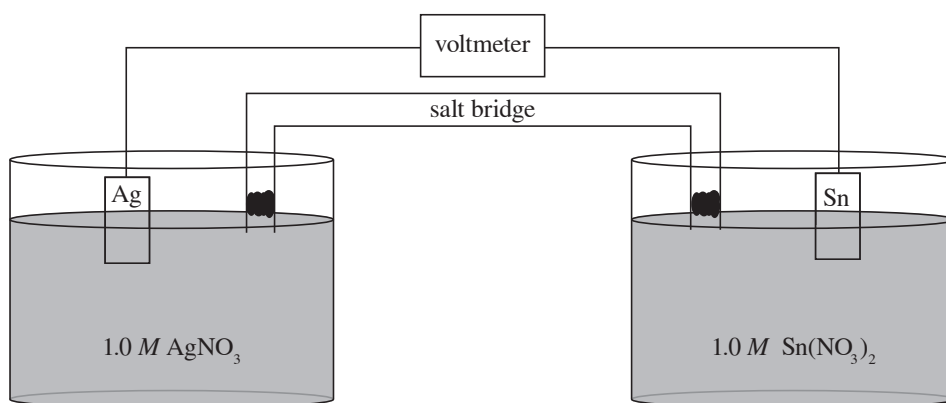

Half-Reaction	Standard Reduction Potential (V)
$\text{Ag}^+ + e^- \rightarrow \text{Ag} (s)$	+0.80
$\text{Sn}^{2+} + 2e^- \rightarrow \text{Sn} (s)$	-0.14

- Write out the balanced net ionic equation that will occur.
- Calculate E°_{cell} .
 - Calculate ΔG° for the cell.
- If the solutions in each half-cell were replaced with 2.0 M solutions of AgNO_3 and $\text{Sn}(\text{NO}_3)_2$, how would that effect the cell potential? Justify your answer.
- What is the purpose of the salt bridge?
 - Suggest the formula for an aqueous solution that would be a good choice to fill the salt bridge. Justify your answer.
- The beaker of $\text{Sn}(\text{NO}_3)_2$ is disconnected from the cell, and the tin electrode is then connected to an outside source of current. Over the course of 10.0 minutes, 1.65 g of tin plates out onto the electrode. What is the amperage of the current source?

GO ON TO THE NEXT PAGE.

3.

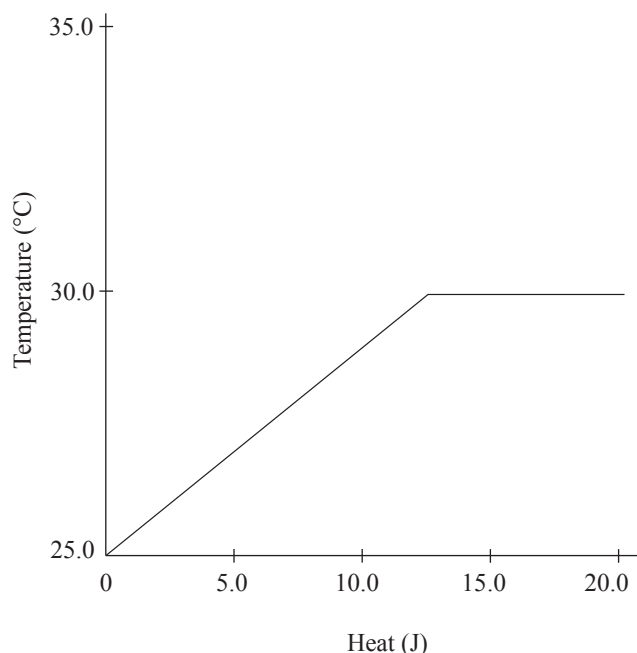

0.10 mol of solid gallium initially at room temperature is heated at a constant rate, and its temperature is tracked, leading to the above graph.

- As heat is added, what is happening to the total entropy of the system? Justify your answer.
- The horizontal portion of the graph indicates a phase change. Explain on a particulate level why the temperature is constant during a phase change.
- Calculate the specific heat capacity of solid gallium in $\text{J g}^{-1} \text{°C}^{-1}$
 - If the specific heat of the solid gallium were greater than what you calculated in (c)(i), how would the slope of the temperature versus heat line change during gallium's solid phase?

The gallium continues to be heated until it fully boils. Assume ideal behavior for the gallium gas.



Substance	H_f° (kJ mol^{-1})
Ga (<i>l</i>)	5.60
Ga (<i>g</i>)	277.1

- Calculate the enthalpy of vaporization for gallium given the above data.
 - The enthalpy of vaporization for gallium is greater than its enthalpy of fusion. Explain why in terms of intermolecular forces.
- Given your answer to (d)(i) and that $\Delta S^\circ = 113.4 \text{ J mol}^{-1} \text{ K}^{-1}$ for the boiling of gallium, what is the boiling point of the gallium?
- After the gallium is fully converted to a gas, it continues to be heated. What would you expect to be true about the velocity distribution of the gaseous gallium atoms as the temperature increases?

GO ON TO THE NEXT PAGE.

4. Sulfurous acid, H_2SO_3 , is a weak diprotic acid.
- Write out the two acid-base dissociations which occur when H_2SO_3 is mixed with water.
 - A 0.50 M solution of H_2SO_3 has a pH of 1.10. Determine K_{a1} for H_2SO_3 .
5. Hypobromous acid, HBrO , is a weak monoprotic acid with a K_a value of 2.0×10^{-9} at 25°C.
- Write out the equilibrium reaction of hypobromous acid with water, identifying any conjugate acid/base pairs present.
 - What would be the percent dissociation of a 0.50 M solution of hypobromous acid?
 - If the 0.50 M solution were diluted, what would happen to the percent dissociation of the HBrO ? Why?
6. Chlorofluorocarbons are byproducts of many different processes that are known to be dangerous to the environment as both as a greenhouse gas, as well as an agent for ozone (O_3) depletion. The accepted mechanism for the latter is:

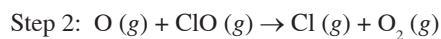

- Write out the full reaction with the above elementary steps, and identify all catalysts and intermediates.
- Describe two ways by which a catalyst can reduce the activation energy of a reaction.
- Both elementary steps in the reaction above are exothermic. On the axes provided, draw a potential reaction mechanism which supports this.

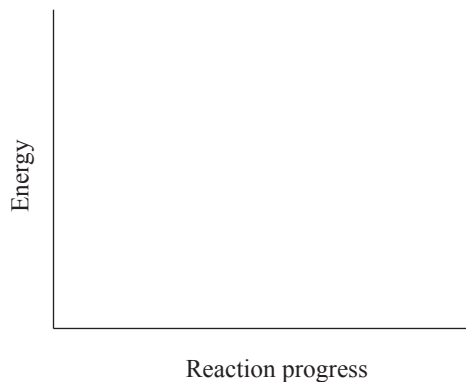

GO ON TO THE NEXT PAGE.

Section II

7. A stock solution of 2.0 M MgCl_2 is dissolved in water.

- (a) (i) In the beaker below, draw a particulate diagram that represents MgCl_2 dissolved in water. The approximate sizes of each atom/ion are provided for you. Your diagram should include at least four water molecules, which should be correctly oriented compared to the ions dissolved in solution.

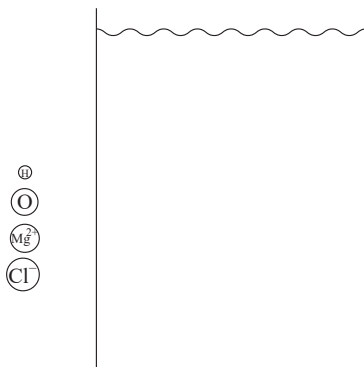

- (ii) Why are the chloride ions from (a)(i) larger than the magnesium ions?
- (b) (i) A student wishes to make up 500 mL of 0.50 M MgCl_2 for an experiment. Explain the best method of doing so, starting with the 2.0 M MgCl_2 solution and utilizing a graduated cylinder and a volumetric flask.
- (ii) What are the concentrations of the Mg^{2+} and Cl^- ions in the new solution?

STOP

END OF EXAM

Completely darken bubbles with a No. 2 pencil. If you make a mistake, be sure to erase mark completely. Erase all stray marks.

1. YOUR NAME: _____
(Print) Last First M.I.

SIGNATURE: _____ DATE: ____/____/____

HOME ADDRESS: _____
(Print) Number and Street

City State Zip Code

PHONE NO.: _____

5. YOUR NAME

First 4 letters of last name				FIRST INIT	MID INIT
(A)	(A)	(A)	(A)	(A)	(A)
(B)	(B)	(B)	(B)	(B)	(B)
(C)	(C)	(C)	(C)	(C)	(C)
(D)	(D)	(D)	(D)	(D)	(D)
(E)	(E)	(E)	(E)	(E)	(E)
(F)	(F)	(F)	(F)	(F)	(F)
(G)	(G)	(G)	(G)	(G)	(G)
(H)	(H)	(H)	(H)	(H)	(H)
(I)	(I)	(I)	(I)	(I)	(I)
(J)	(J)	(J)	(J)	(J)	(J)
(K)	(K)	(K)	(K)	(K)	(K)
(L)	(L)	(L)	(L)	(L)	(L)
(M)	(M)	(M)	(M)	(M)	(M)
(N)	(N)	(N)	(N)	(N)	(N)
(O)	(O)	(O)	(O)	(O)	(O)
(P)	(P)	(P)	(P)	(P)	(P)
(Q)	(Q)	(Q)	(Q)	(Q)	(Q)
(R)	(R)	(R)	(R)	(R)	(R)
(S)	(S)	(S)	(S)	(S)	(S)
(T)	(T)	(T)	(T)	(T)	(T)
(U)	(U)	(U)	(U)	(U)	(U)
(V)	(V)	(V)	(V)	(V)	(V)
(W)	(W)	(W)	(W)	(W)	(W)
(X)	(X)	(X)	(X)	(X)	(X)
(Y)	(Y)	(Y)	(Y)	(Y)	(Y)
(Z)	(Z)	(Z)	(Z)	(Z)	(Z)

IMPORTANT: Please fill in these boxes exactly as shown on the back cover of your test book.

2. TEST FORM

3. TEST CODE				4. REGISTRATION NUMBER									
(0)	(A)	(J)	(0)	(0)	(0)	(0)	(0)	(0)	(0)	(0)	(0)	(0)	(0)
(1)	(B)	(K)	(1)	(1)	(1)	(1)	(1)	(1)	(1)	(1)	(1)	(1)	(1)
(2)	(C)	(L)	(2)	(2)	(2)	(2)	(2)	(2)	(2)	(2)	(2)	(2)	(2)
(3)	(D)	(M)	(3)	(3)	(3)	(3)	(3)	(3)	(3)	(3)	(3)	(3)	(3)
(4)	(E)	(N)	(4)	(4)	(4)	(4)	(4)	(4)	(4)	(4)	(4)	(4)	(4)
(5)	(F)	(O)	(5)	(5)	(5)	(5)	(5)	(5)	(5)	(5)	(5)	(5)	(5)
(6)	(G)	(P)	(6)	(6)	(6)	(6)	(6)	(6)	(6)	(6)	(6)	(6)	(6)
(7)	(H)	(Q)	(7)	(7)	(7)	(7)	(7)	(7)	(7)	(7)	(7)	(7)	(7)
(8)	(I)	(R)	(8)	(8)	(8)	(8)	(8)	(8)	(8)	(8)	(8)	(8)	(8)
(9)			(9)	(9)	(9)	(9)	(9)	(9)	(9)	(9)	(9)	(9)	(9)

6. DATE OF BIRTH

Month	Day		Year	
() JAN				
() FEB	(0)	(0)	(0)	(0)
() MAR	(1)	(1)	(1)	(1)
() APR	(2)	(2)	(2)	(2)
() MAY	(3)	(3)	(3)	(3)
() JUN		(4)	(4)	(4)
() JUL		(5)	(5)	(5)
() AUG		(6)	(6)	(6)
() SEP		(7)	(7)	(7)
() OCT		(8)	(8)	(8)
() NOV		(9)	(9)	(9)
() DEC				

7. GENDER

() MALE

() FEMALE



1. (A) (B) (C) (D)	21. (A) (B) (C) (D)	41. (A) (B) (C) (D)
2. (A) (B) (C) (D)	22. (A) (B) (C) (D)	42. (A) (B) (C) (D)
3. (A) (B) (C) (D)	23. (A) (B) (C) (D)	43. (A) (B) (C) (D)
4. (A) (B) (C) (D)	24. (A) (B) (C) (D)	44. (A) (B) (C) (D)
5. (A) (B) (C) (D)	25. (A) (B) (C) (D)	45. (A) (B) (C) (D)
6. (A) (B) (C) (D)	26. (A) (B) (C) (D)	46. (A) (B) (C) (D)
7. (A) (B) (C) (D)	27. (A) (B) (C) (D)	47. (A) (B) (C) (D)
8. (A) (B) (C) (D)	28. (A) (B) (C) (D)	48. (A) (B) (C) (D)
9. (A) (B) (C) (D)	29. (A) (B) (C) (D)	49. (A) (B) (C) (D)
10. (A) (B) (C) (D)	30. (A) (B) (C) (D)	50. (A) (B) (C) (D)
11. (A) (B) (C) (D)	31. (A) (B) (C) (D)	51. (A) (B) (C) (D)
12. (A) (B) (C) (D)	32. (A) (B) (C) (D)	52. (A) (B) (C) (D)
13. (A) (B) (C) (D)	33. (A) (B) (C) (D)	53. (A) (B) (C) (D)
14. (A) (B) (C) (D)	34. (A) (B) (C) (D)	54. (A) (B) (C) (D)
15. (A) (B) (C) (D)	35. (A) (B) (C) (D)	55. (A) (B) (C) (D)
16. (A) (B) (C) (D)	36. (A) (B) (C) (D)	56. (A) (B) (C) (D)
17. (A) (B) (C) (D)	37. (A) (B) (C) (D)	57. (A) (B) (C) (D)
18. (A) (B) (C) (D)	38. (A) (B) (C) (D)	58. (A) (B) (C) (D)
19. (A) (B) (C) (D)	39. (A) (B) (C) (D)	59. (A) (B) (C) (D)
20. (A) (B) (C) (D)	40. (A) (B) (C) (D)	60. (A) (B) (C) (D)