

honeycombs

(multiple of 8 stitches)

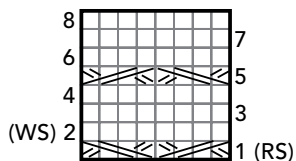

easy

offset cables

(multiple of 9 stitches)

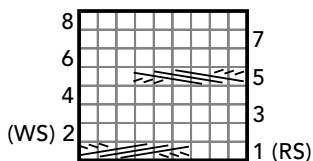

easy

shifting sand

(multiple of 8 stitches)

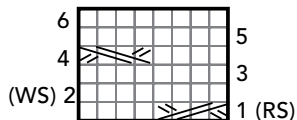

pinched cables

(multiple of 12 stitches plus 2 stitches)

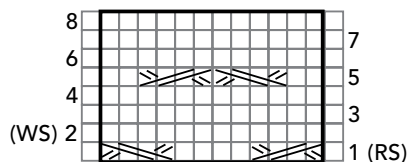

easy

shuffling cables

easy

(multiple of 5 stitches plus 1 stitch)

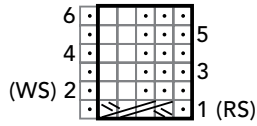

waterfall cables

easy

(multiple of 18 stitches plus 3 stitches)

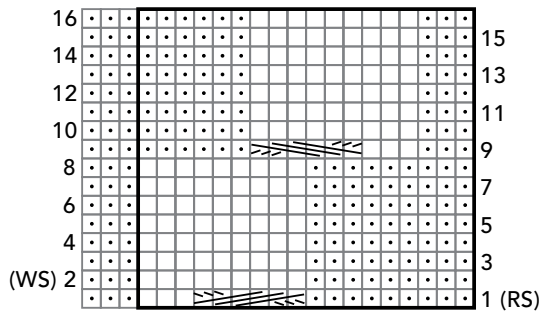

ukuleles

 easy

(multiple of 8 stitches)

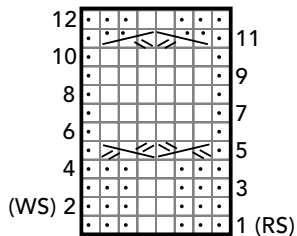

diagonal texture

easy

(multiple of 6 stitches plus 2 stitches)

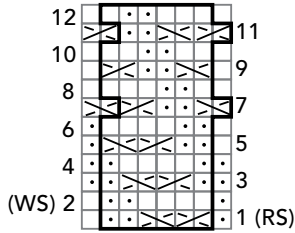

inishmore cable

easy

(over 20 stitches on a reverse stockinette background)

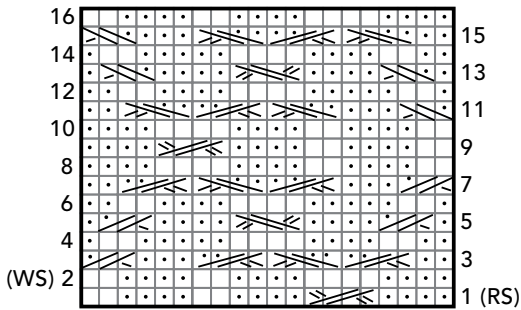

x's and o's

easy

(over 15 stitches on a reverse stockinette background)

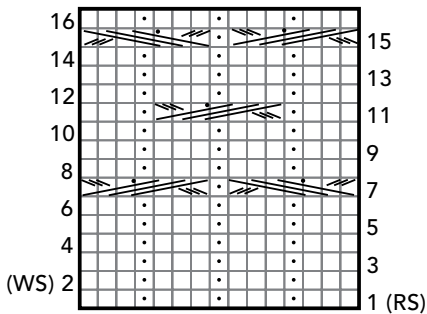

branches

easy

(over 18 stitches on a reverse stockinette background)

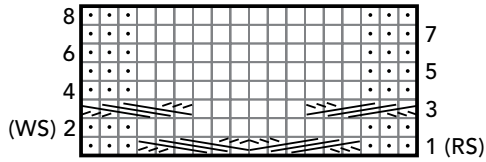

sculpted diamonds

easy

(multiple of 10 stitches plus 2 stitches)

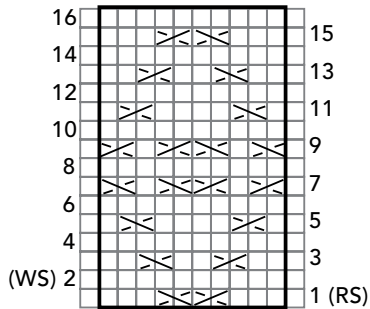

wishbone ribs

 easy

(multiple of 16 stitches)

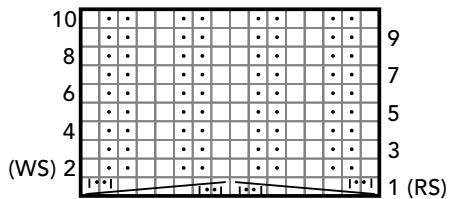

cables and plaits

easy

(over 12 stitches on a reverse stockinette background)

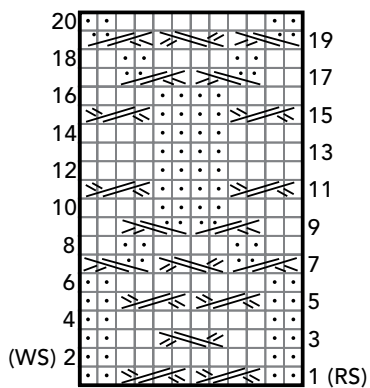

rag dolls

easy

(multiple of 8 stitches plus 2 stitches)

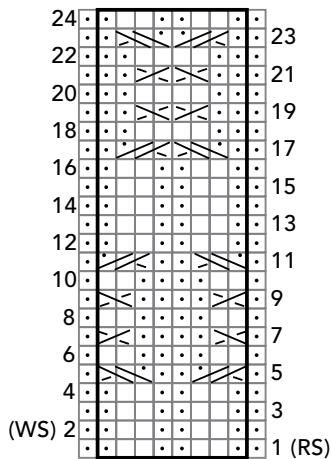

traveling garter ribs

easy

(multiple of 24 stitches plus 2 stitches)

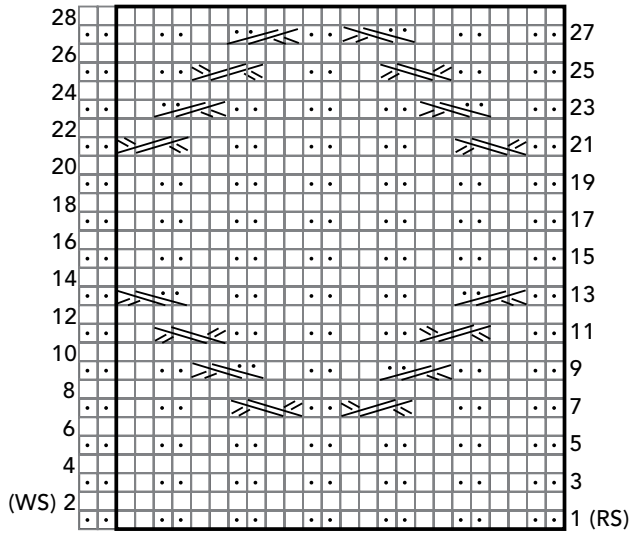

dimpled diamonds

easy

(over 18 stitches on a reverse stockinette background)

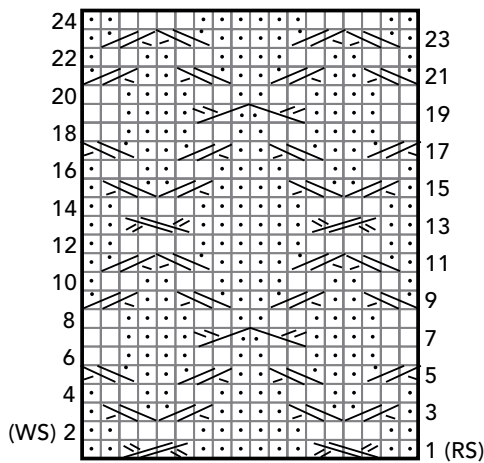

framed cable

easy

(over 20 stitches on a reverse stockinette background)

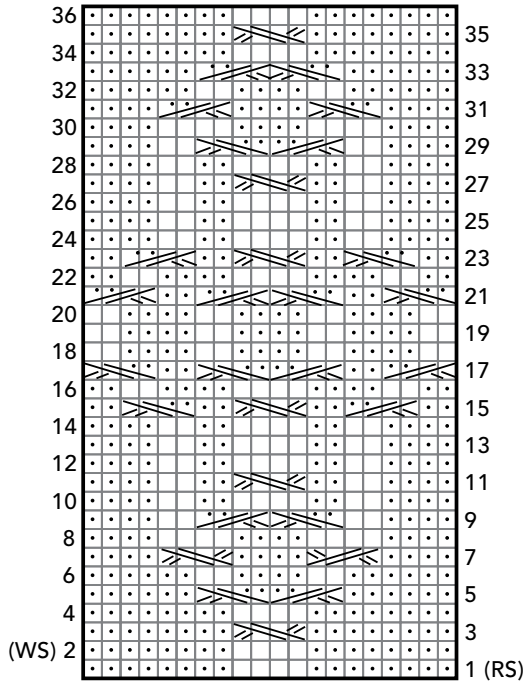

entwined diamonds panel

easy

(over 22 stitches on a reverse stockinette background)

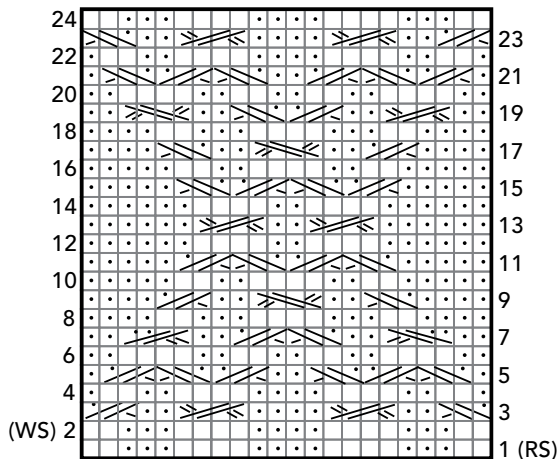

overlapping petals

easy

(multiple of 18 stitches plus 10 stitches)

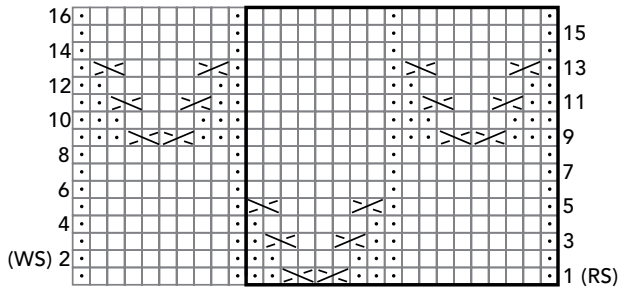

sailor's cables

easy

(multiple of 26 stitches plus 14 stitches)

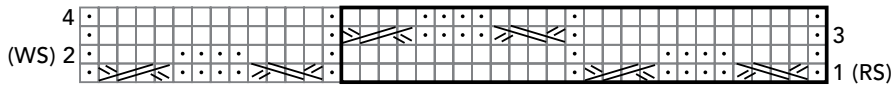

hanging fuchsia

easy

(multiple of 8 stitches)

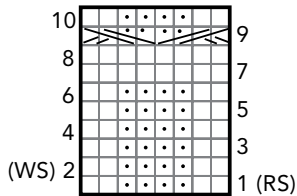

crests

easy

(multiple of 3 stitches plus 2 stitches)

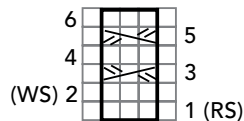

cinched cable

easy

(over 12 stitches on a reverse stockinette background)

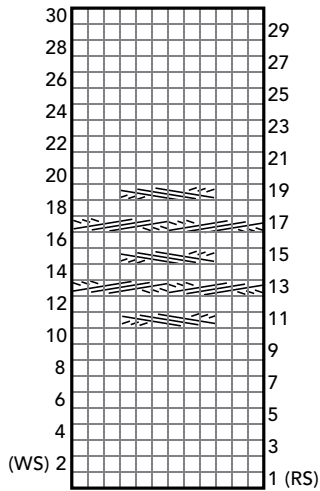

taffy cable

easy

(over 18 stitches on a reverse stockinette background)

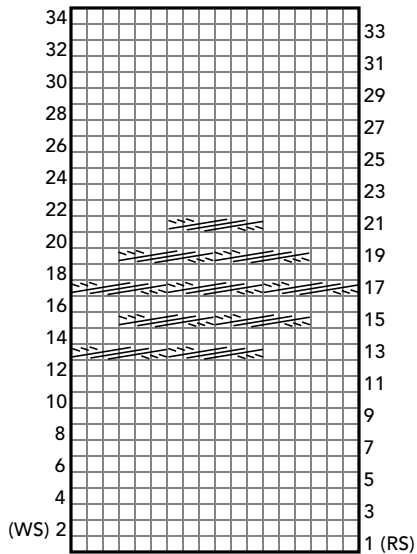

rippling cables

(multiple of 10 stitches plus 7 stitches)

easy

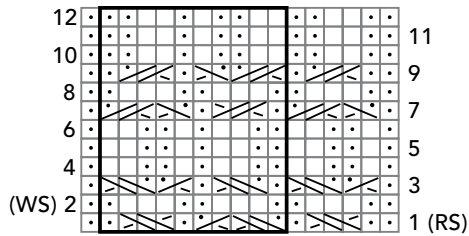

quilted cables

(multiple of 18 stitches)

easy

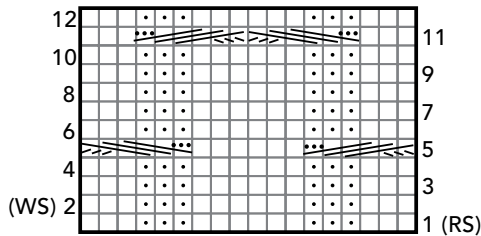

wexford braid

(over 26 stitches on a reverse stockinette background)

easy

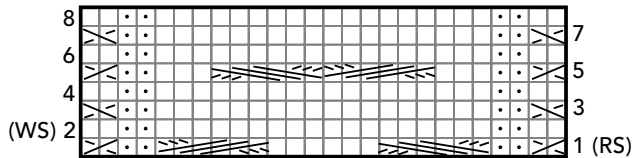

buckeye cables

easy

(multiple of 24 stitches plus 12 stitches)

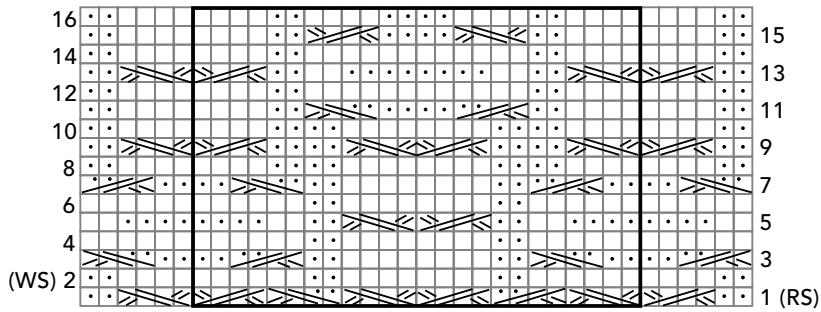

claddaghduff aran cable

easy

(over 26 stitches on a reverse stockinette background)

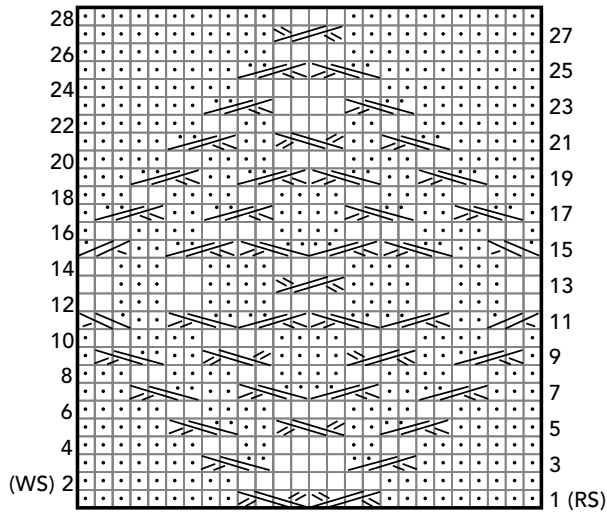

o'briensbridge cables

easy

(multiple of 28 stitches plus 28 stitches)

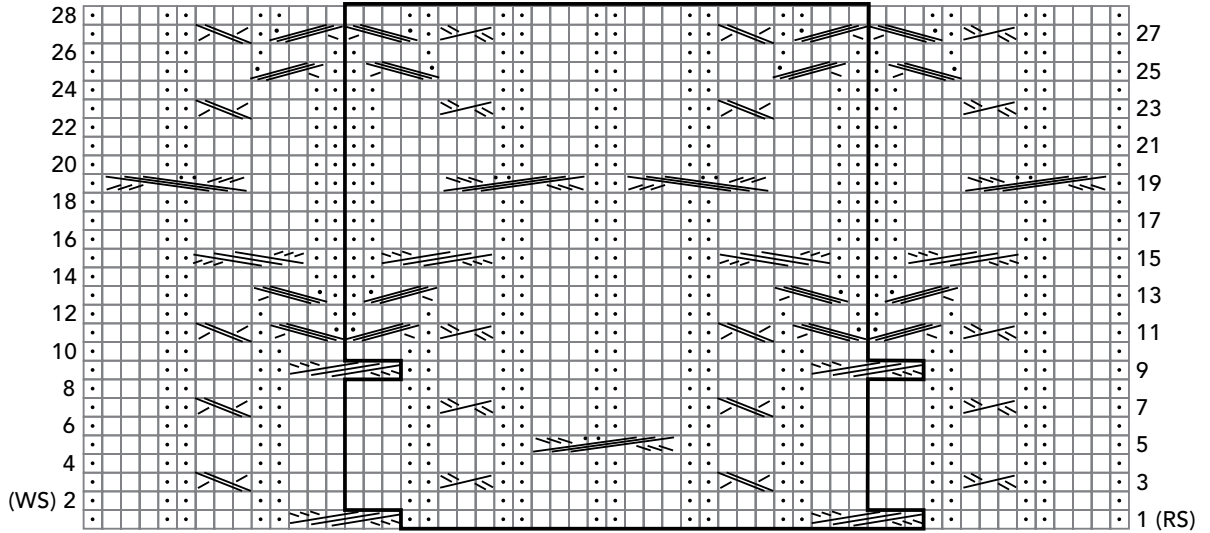

tipperary textile pattern

easy

(multiple of 28 stitches)

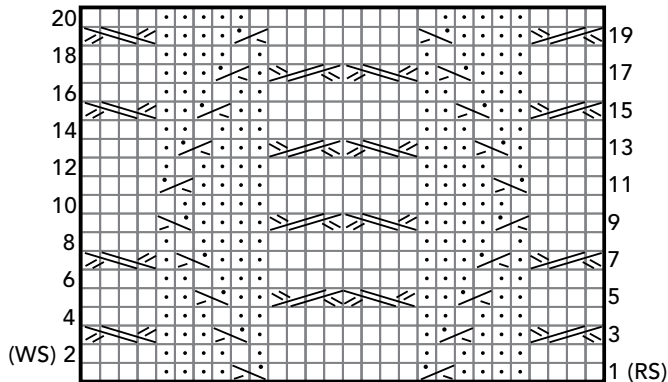

braided oval

easy

(over 20 stitches on a reverse stockinette background)

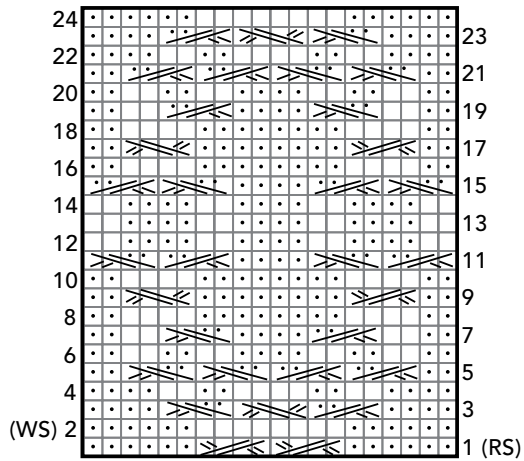

lamp posts

easy

(over 20 stitches on a reverse stockinette background)

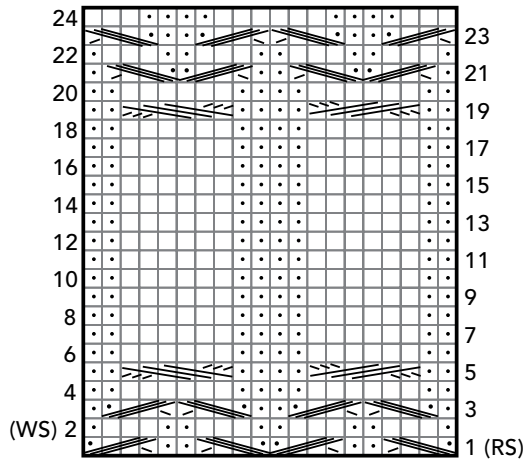

ribs on the move

easy

(multiple of 10 stitches plus 10 stitches)

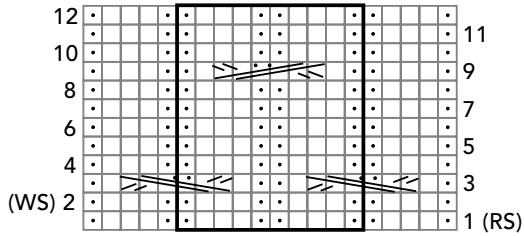

little crescents

easy

(multiple of 4 stitches plus 4 stitches)

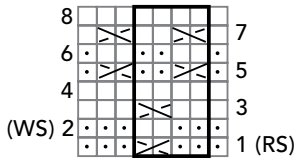

woven ribs

 easy

(multiple of 12 stitches plus 12 stitches)

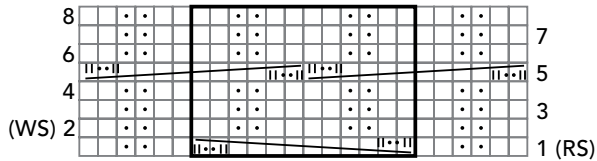

wrapped cable

easy

(over 12 stitches on a reverse stockinette background)

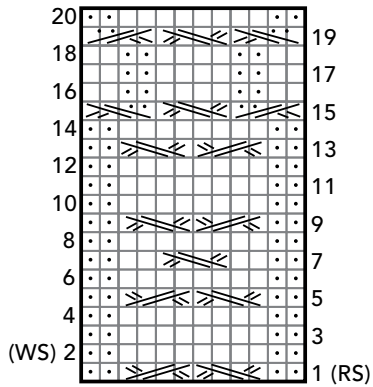

intertwined ropes

easy

(multiple of 22 stitches plus 1 stitch)

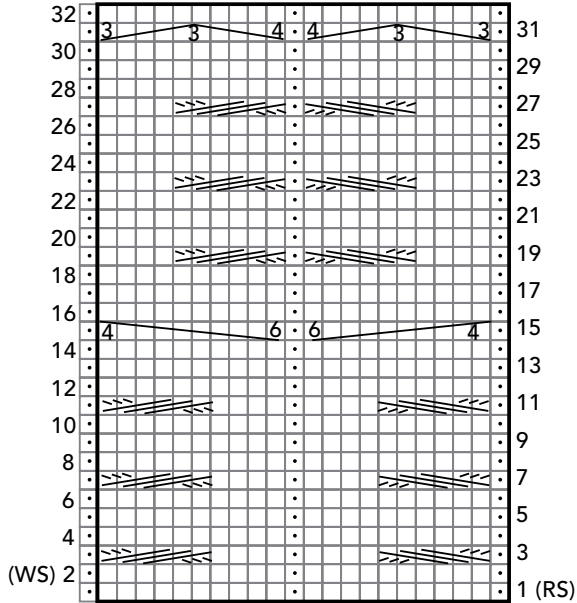

linked cables panel

easy

(over 14 stitches on a reverse stockinette background)

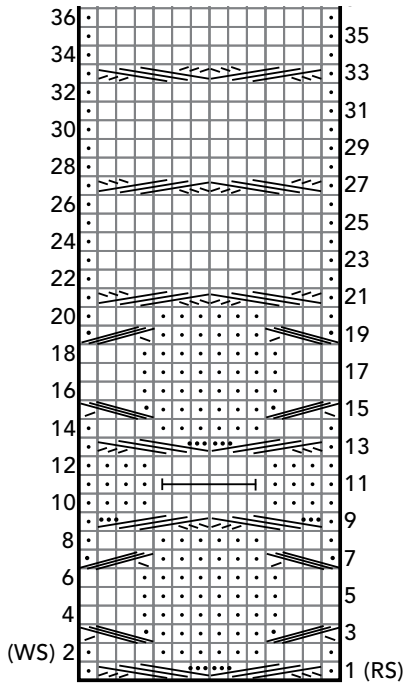

spinning tops

easy

(multiple of 16 stitches plus 14 stitches)

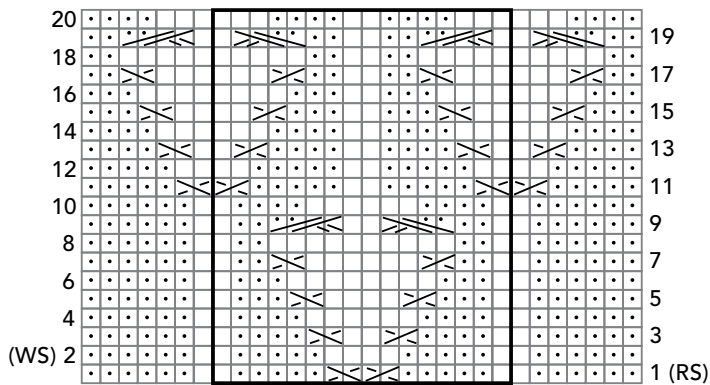

diverging cable

easy

(over 19 stitches on a reverse stockinette background)

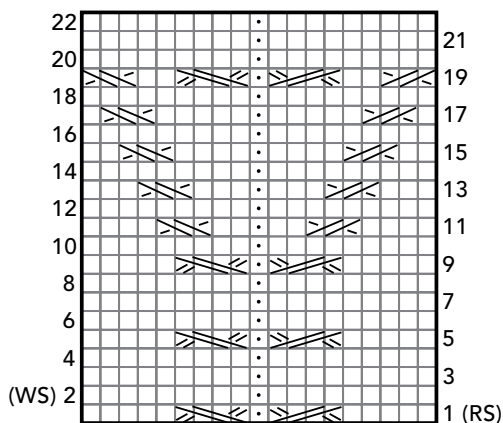

sheenagh panel

easy

(over 34 stitches on a reverse stockinette background)

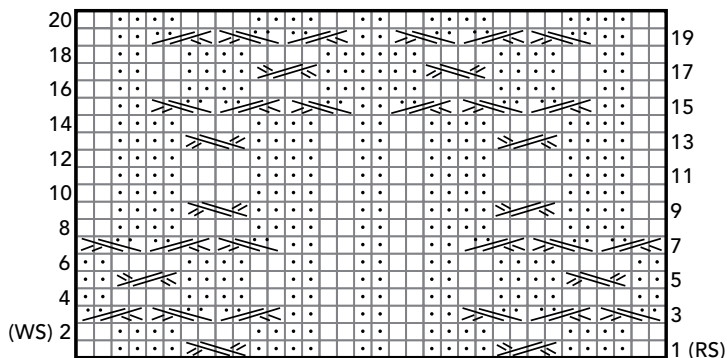

ballinlough cables

easy

(multiple of 32 stitches plus 16 stitches)

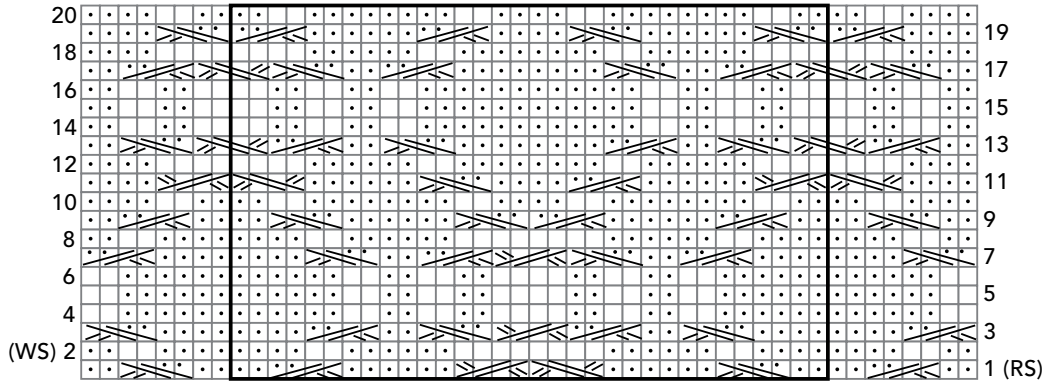

trellis and ribs

easy

(multiple of 24 stitches plus 16 stitches)

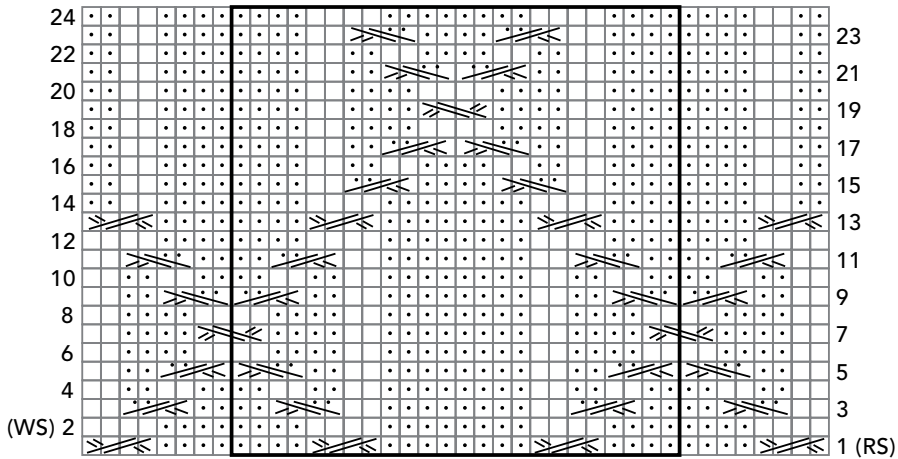

nautical braids

easy

(over 32 stitches on a reverse stockinette background)

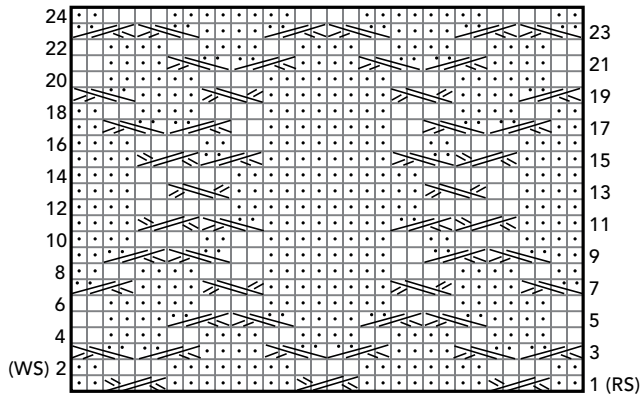

braided lattice

easy

(multiple of 12 stitches plus 14 stitches)

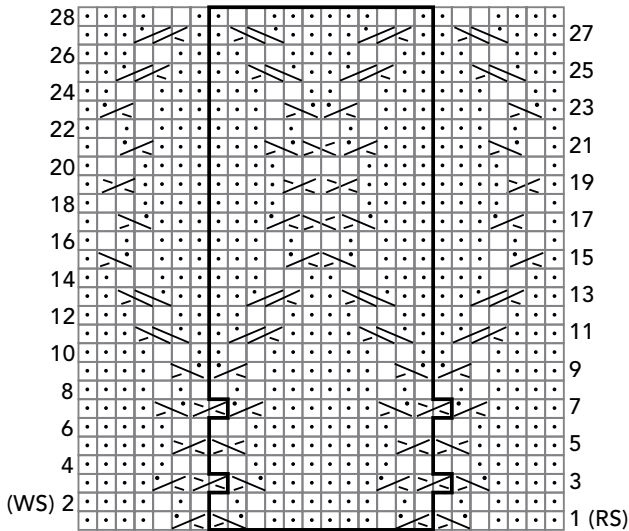

diamonds and kisses

easy

(multiple of 30 stitches plus 2 stitches)

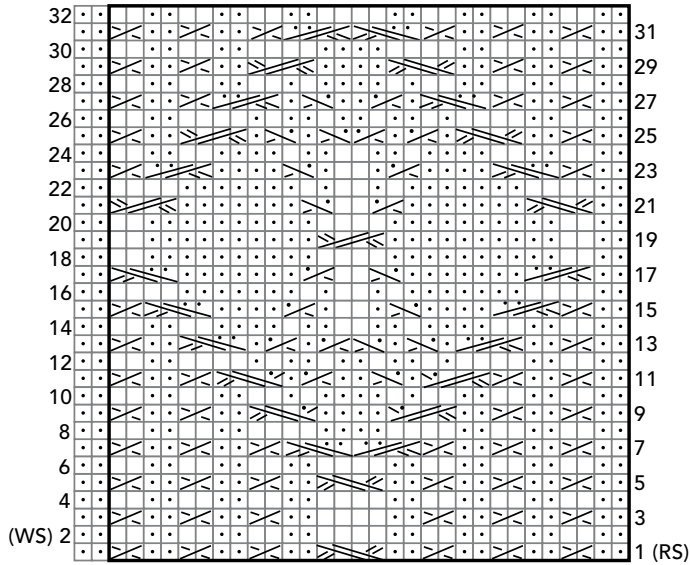

irish panel

easy

(over 24 stitches on a reverse stockinette background)

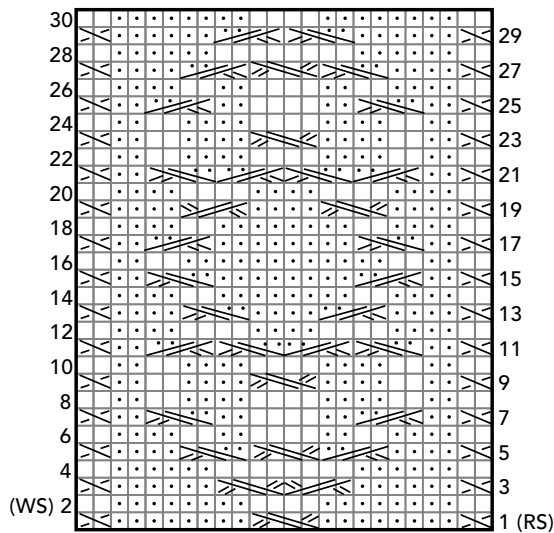

wellingtonbridge cable easy

(over 32 stitches on a reverse stockinette background)

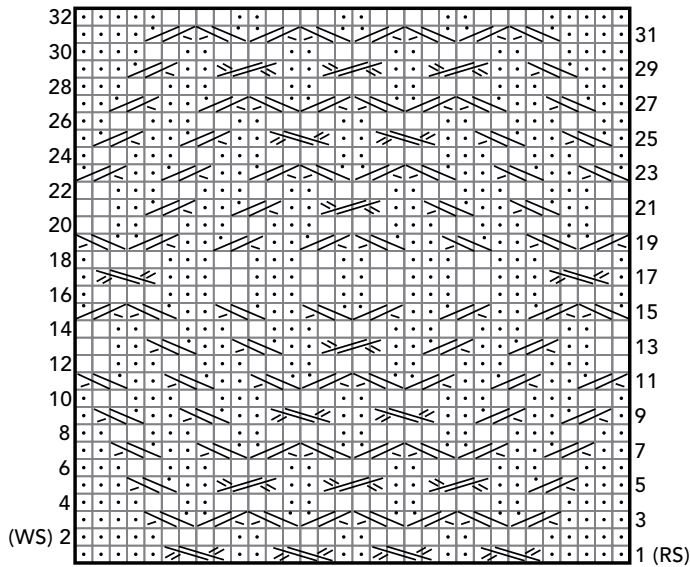

mariner's cables easy

(multiple of 12 stitches plus 12 stitches)

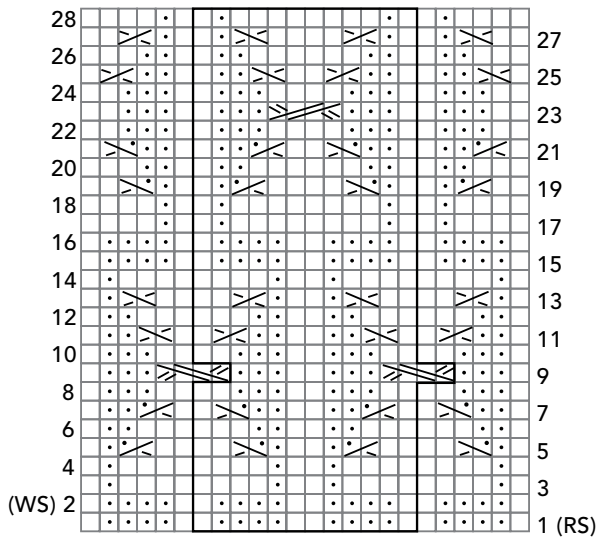

sweeping ribs

easy

(multiple of 40 stitches plus 22 stitches)

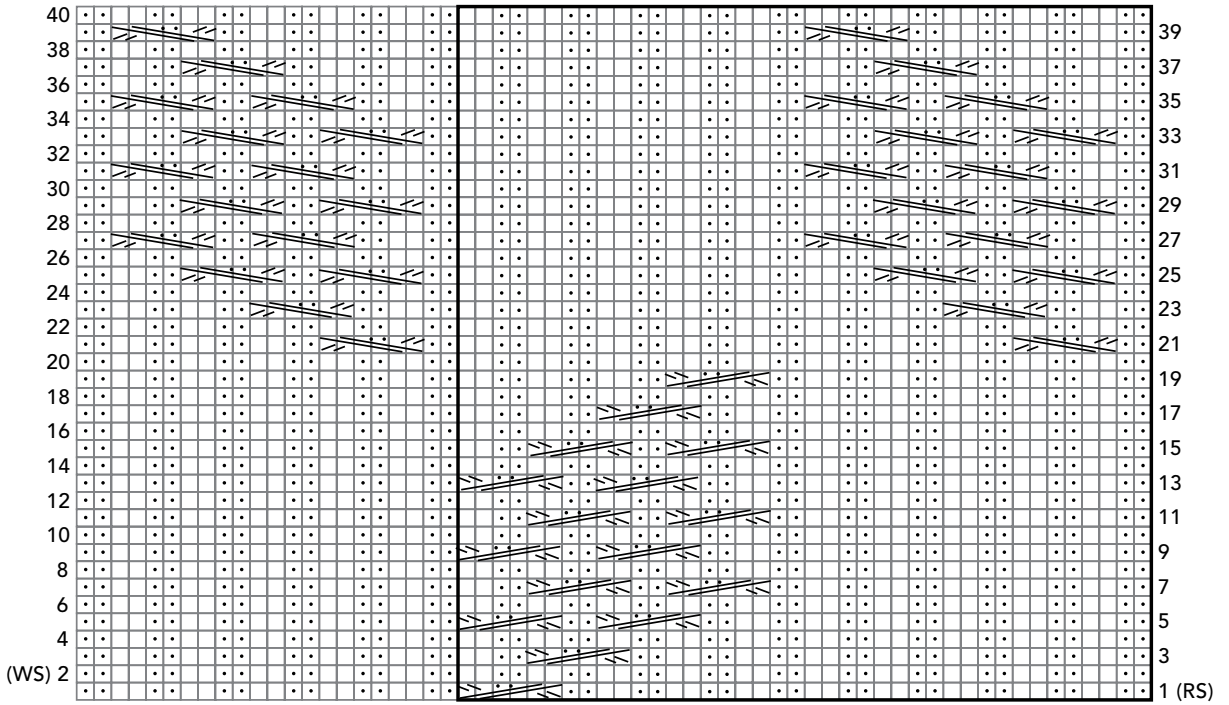

chain links

easy

(multiple of 16 stitches plus 10 stitches)

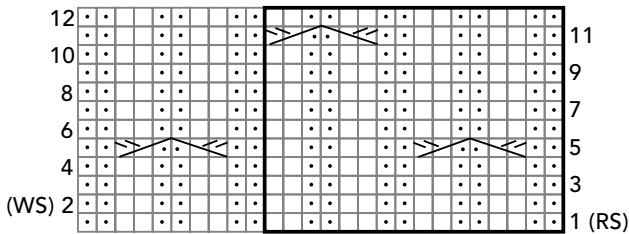

tuxedo cable



(over 29 stitches on a reverse stockinette background)

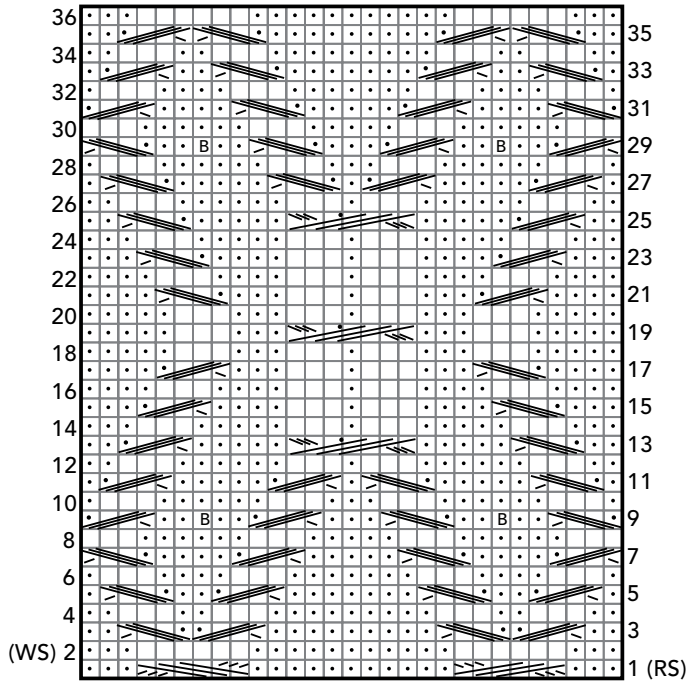

reversible rope cables



(multiple of 8 stitches)



meandering cables

easy

(multiple of 24 stitches plus 14 stitches)

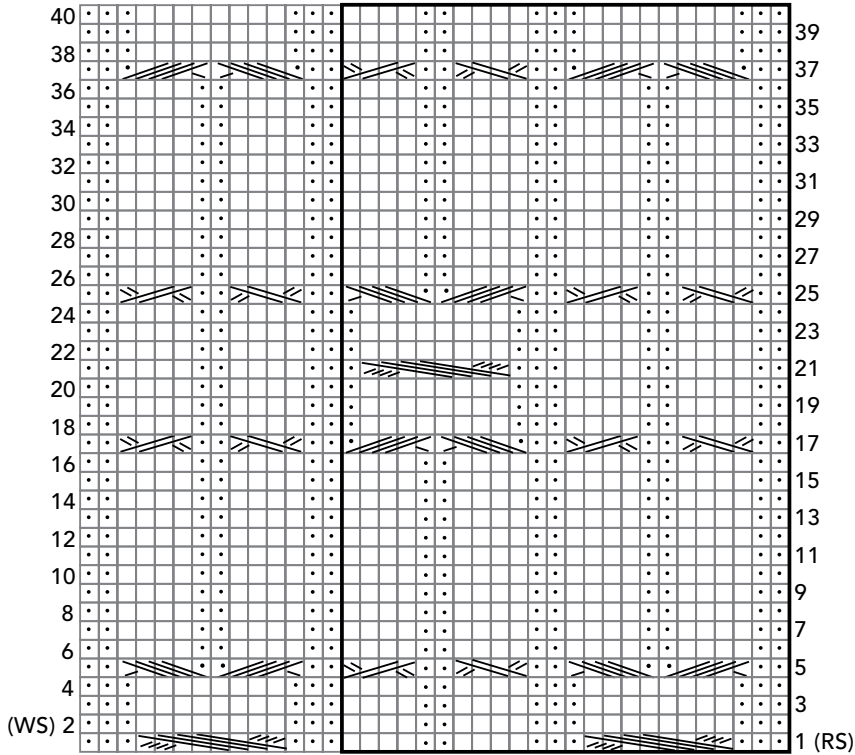

reversible zigzag cables



easy

(multiple of 8 stitches)

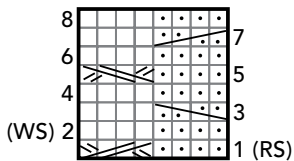

ribbed cable

easy

(over 17 stitches on a reverse stockinette background)

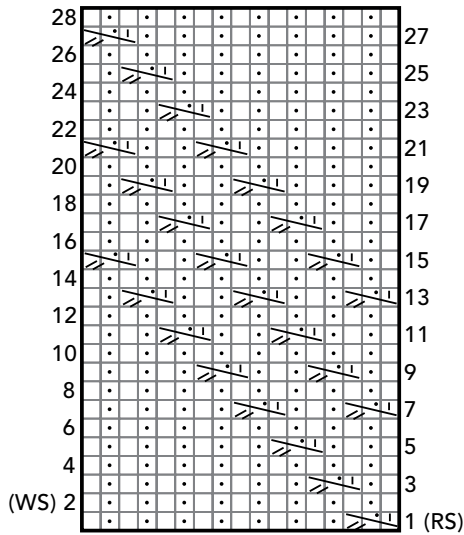

tiny braids

(multiple of 3 stitches)

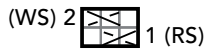

drapey cable

(over 20 stitches on a reverse stockinette background)

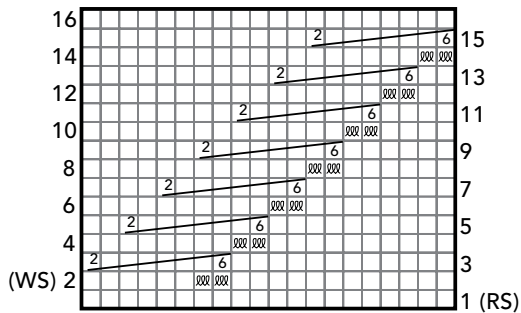

cables and ridges

(multiple of 10 stitches plus 6 stitches)

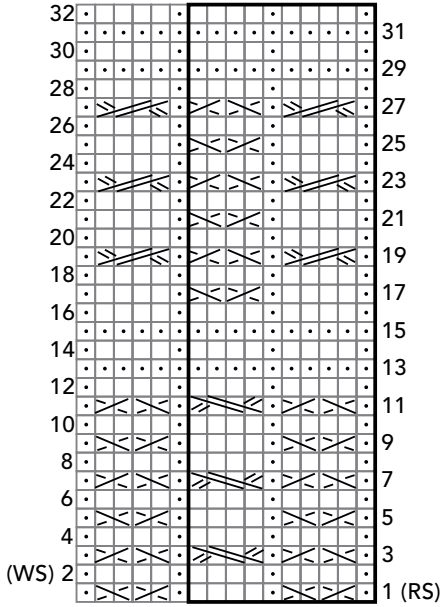

racked rib

(multiple of 2 stitches plus 2 stitches)

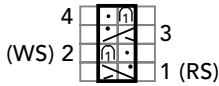

reverse ring cable panel

(over 20 stitches on a reverse stockinette background)

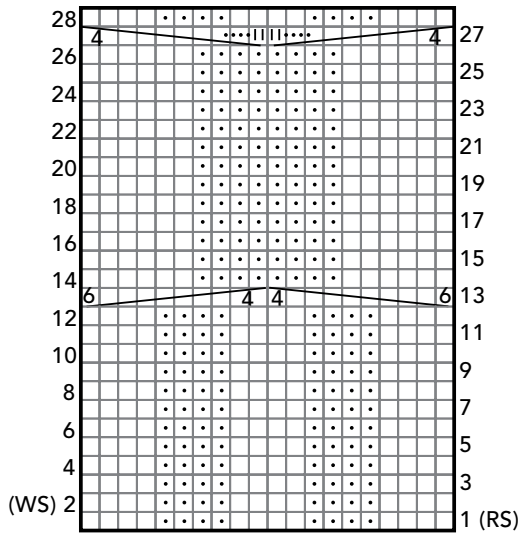

cabled argyle

(multiple of 14 stitches plus 10 stitches)

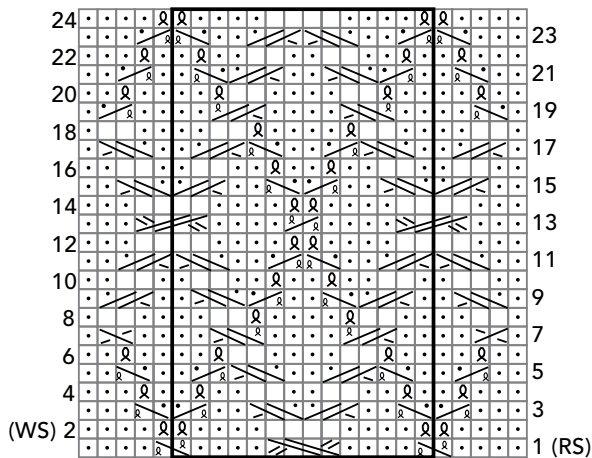

cornflower panel

(over 24 stitches on a reverse stockinette background)

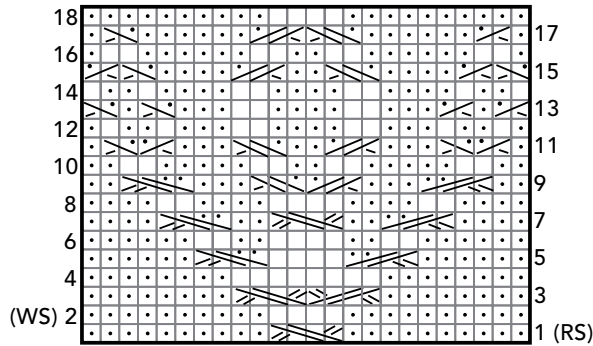

toggles and links

(multiple of 32 stitches plus 19 stitches)

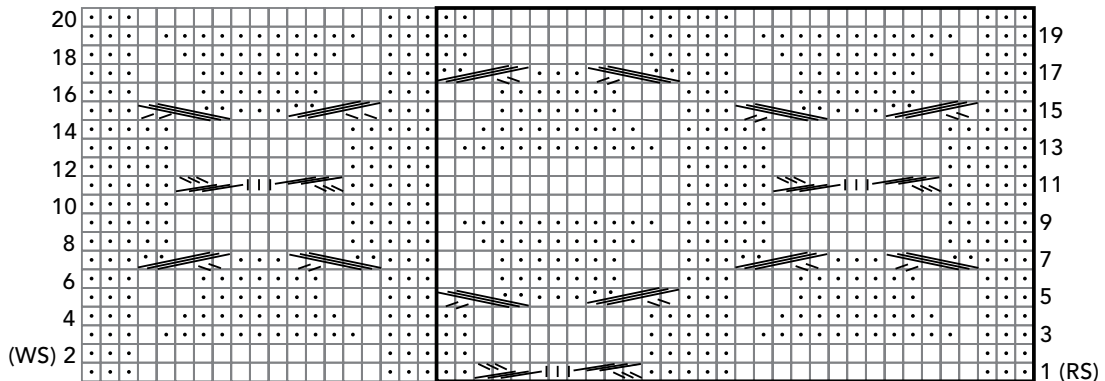

deconstructed cables

(multiple of 11 stitches plus 8 stitches, increases to multiple of 12 stitches plus 9 stitches)

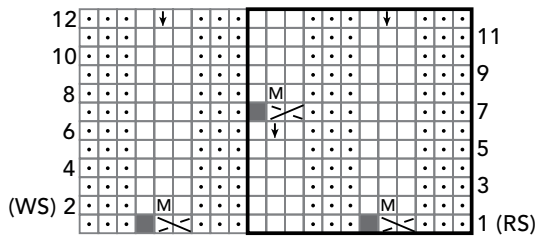

heart cable panel

(cover 20 stitches on a reverse stockinette background)

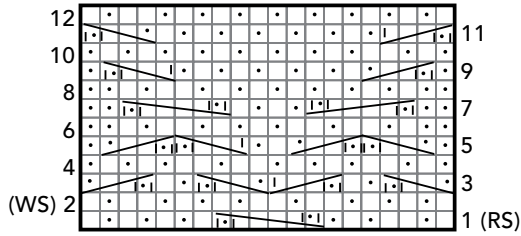

boxes 'n' braids

(multiple of 14 stitches plus 8 stitches)

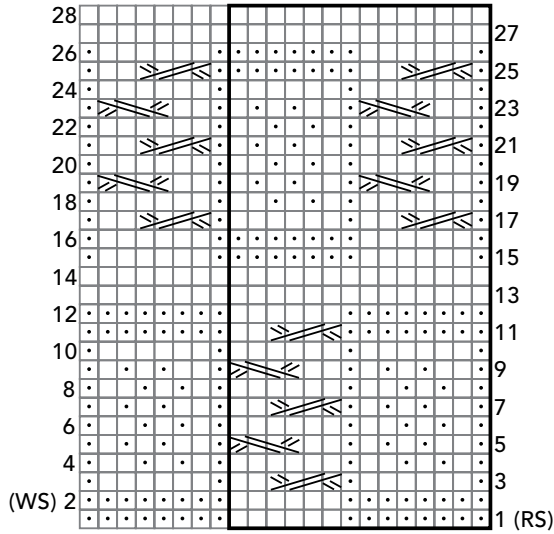

overlapping rings

(multiple of 10 stitches plus 11 stitches)

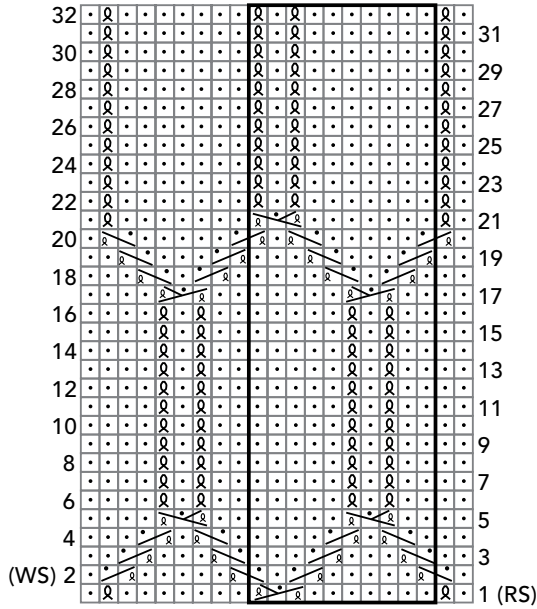

intertwined argyle

(multiple of 16 stitches plus 14 stitches)

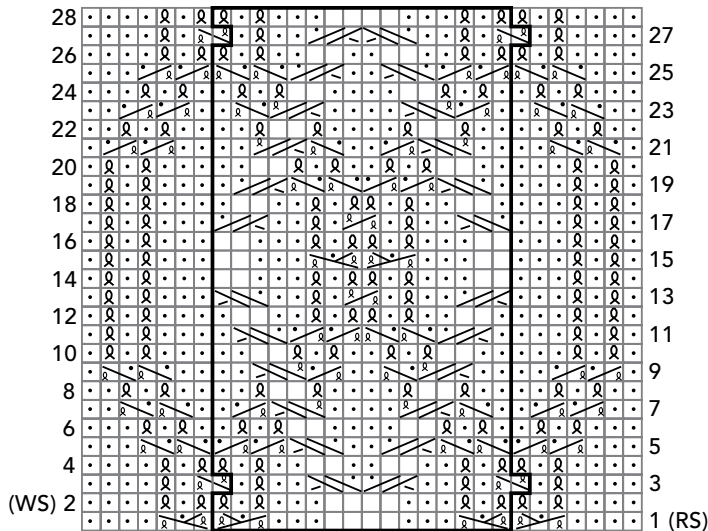

bavarian bells

(over 20 stitches on a reverse stockinette background)

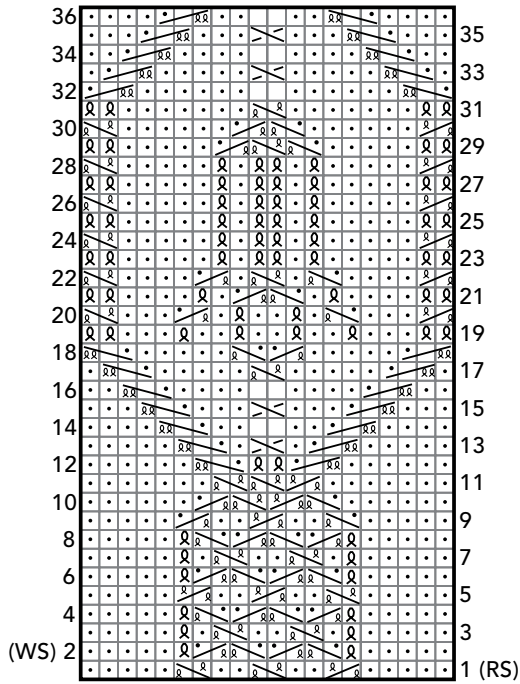

framed tulips

(over 22 stitches on a reverse stockinette background)

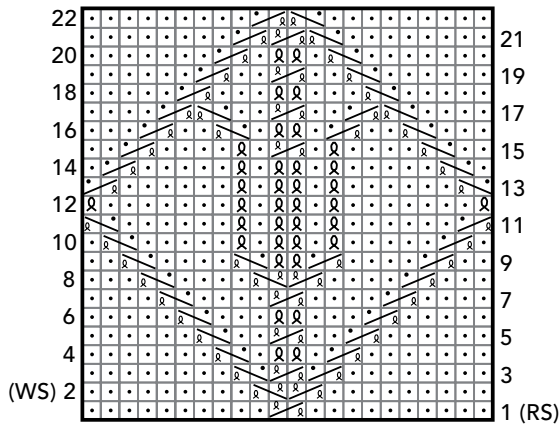

alpine tulips

(over 10 stitches on a reverse stockinette background)

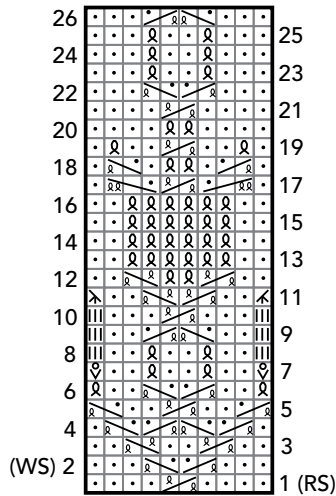

laced cables

(multiple of 40 stitches plus 2 stitches)

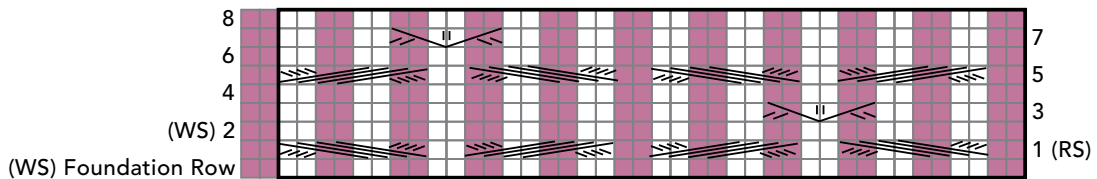

Color Key ■ = Color A
□ = Color B

two-color rope cables

(multiple of 20 stitches plus 2 stitches)

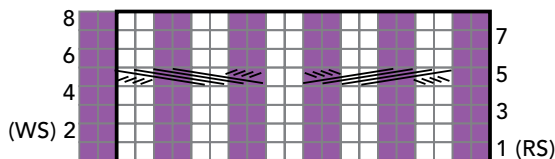

Color Key ■ = Color A
□ = Color B

zigzag cables

(multiple of 12 stitches plus 2 stitches)

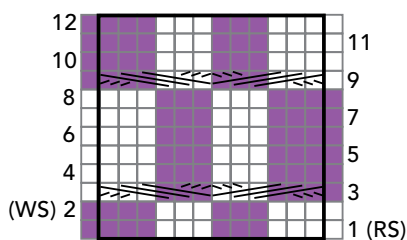

Color Key □ = Color A
■ = Color B

two-color wishbone cables

(multiple of 8 stitches)

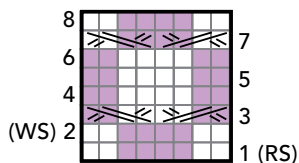

Color Key □ = Color A
■ = Color B

two-color hanover cables

(multiple of 40 stitches plus 2 stitches)

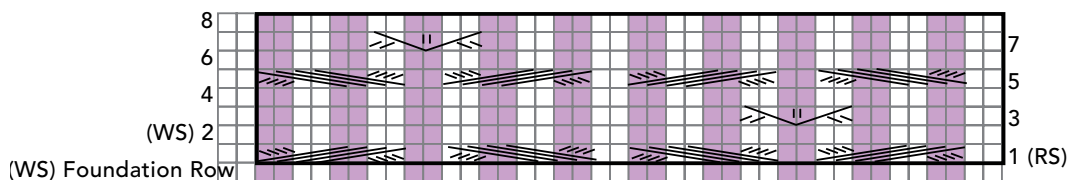

Color Key ■ = Color A
□ = Color B

“awareness ribbon” cable

(over 11 stitches, increases to 17 stitches, on a reverse stockinette background)

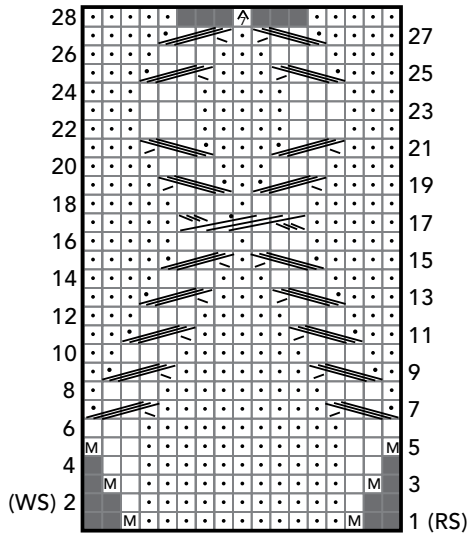

enniskerry cable

(over 22 stitches, increases to 30 stitches, on a reverse stockinette background)

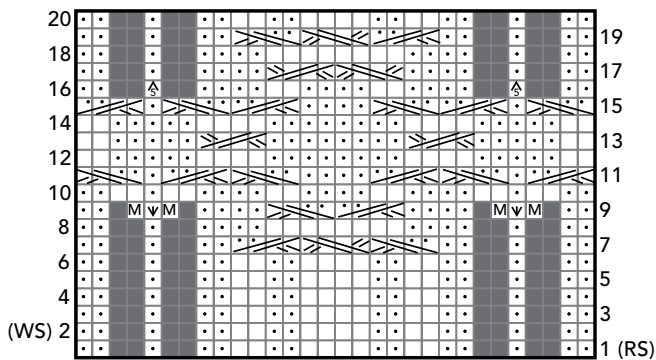

caedmon celtic knot

(over 27 stitches, increases to 45 stitches, on a reverse stockinette background)

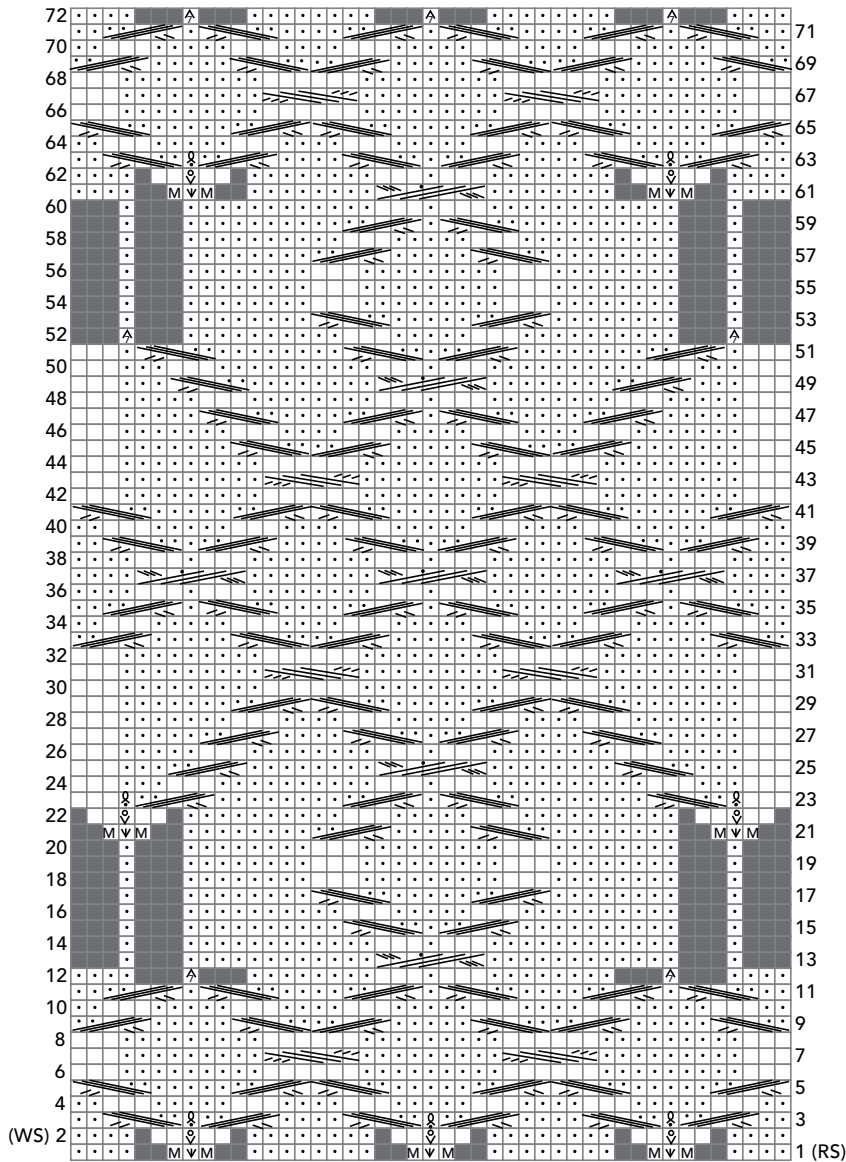

celtic swirl

(over 39 stitches, increases to 45 stitches, on a reverse stockinette background)

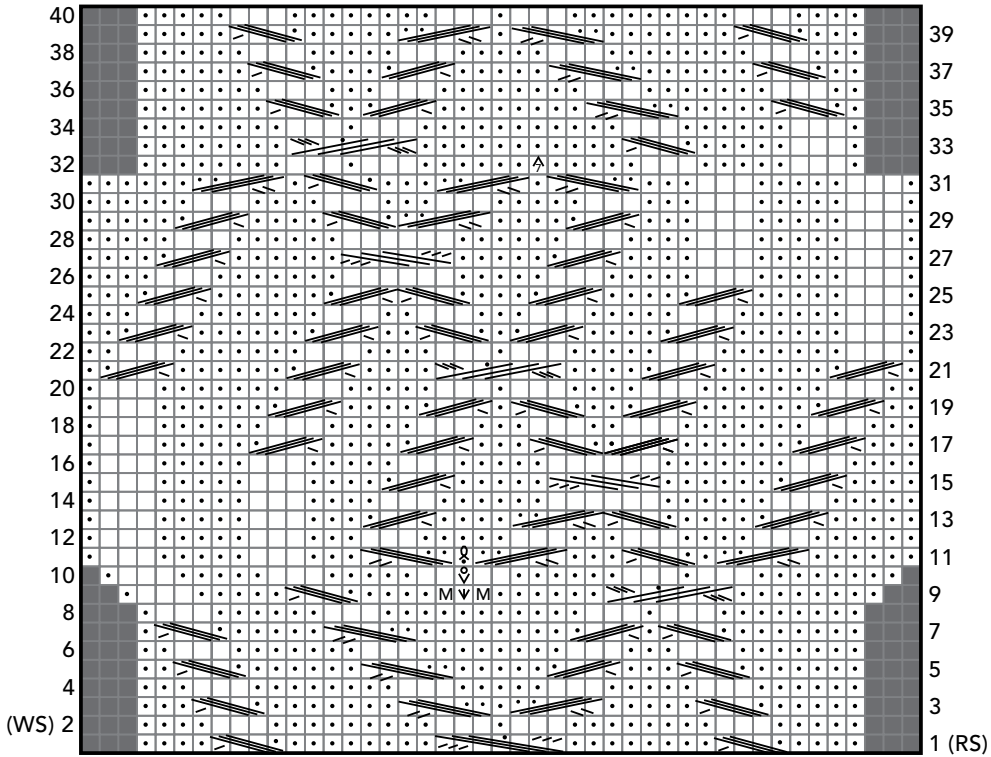

reversible kerry braids



(multiple of 24 stitches plus 6 stitches)

Chart A

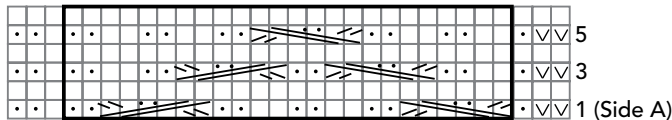
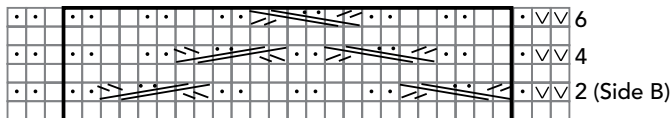

Chart B



reversible dungourney cables



(multiple of 24 stitches plus 6 stitches)

Chart A

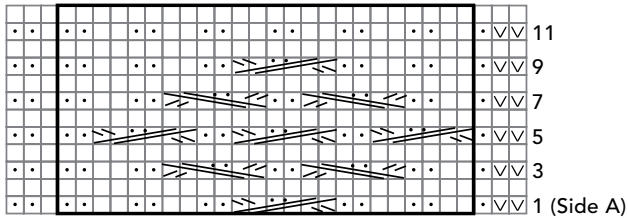

Chart B

